

2017 big trailers series

grape  
trailers

*Since 1960*

**ZACCARIA**  
QUALITY TRAILERS



# grape trailer

1

## ZAM 200 BL DOUBLE



## TWO-WAY TIPPING DUMPER ZAM 200 BL DOUBLE VAT

### Standard equipment:

AISI 304 floureshed stainless steel body.  
Hydraulic two-way tipping system. Independent vats

Watertight extension on right side with  
Hydraulic opening and PVC covering.

Cantilever leaf spring suspensions.

Regulating connecting rod.

Braking system control (pneumatic brake).

Industrial axles (10 studs);  
self-steering front/rear axles.

Stainless steel light bar.

PVC canister H2O. PVC mudguard.

Hydraulic parking stand. PVC toolbox.

### On demand:

Hydraulic opening of the double side extension

Electro-hydraulic unit with remote radio control.

Stainless steel pull-out middle pole.

Steering adjuster.

PVC manual covering.

Hydraulic side covering.

Monitor/camera kit. Special draw bar eye for export.

| MODEL                        | BODY SIZE<br>cm          | SIDE EXTENSION<br>H cm | HYDRAULIC EXTENSION<br>H cm | VOLUME<br>m <sup>3</sup> | AXLES | TARE<br>tons | GROSS WEIG.<br>tons | TYRES TYPE          | BRAKE SYSTEM | BRAKE ASSEMBLY     |
|------------------------------|--------------------------|------------------------|-----------------------------|--------------------------|-------|--------------|---------------------|---------------------|--------------|--------------------|
| ZAM 200 BLP<br><b>DOUBLE</b> | 300x240x130<br>N° 2 VATS | 48                     | 48                          | 20                       | 3     | 5.5          | 20                  | 385/55 R22,5<br>new | pneumatic    | 406x120<br>10 Col. |
| ZAM 200 BLI<br><b>DOUBLE</b> |                          |                        |                             |                          |       |              |                     |                     | hydraulic    |                    |

# grape trailer

2



ZAM 200 BL DOUBLE  
PVC manual covering

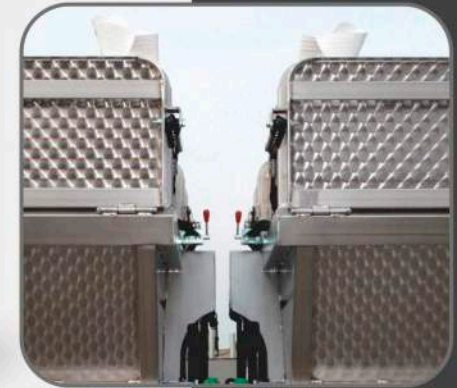

ZAM 200 BL  
DOUBLE

## TECHNICAL DATA

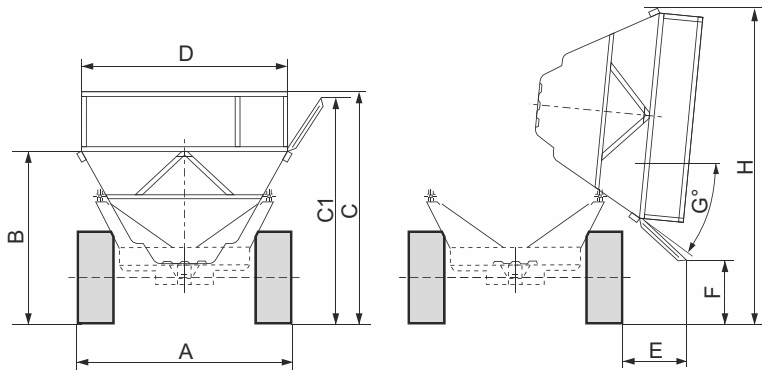

| MODEL             | mm   | B mm | C mm | C1 mm | D mm | E mm | F mm | G gradi | H mm |
|-------------------|------|------|------|-------|------|------|------|---------|------|
| ZAM 200 BL DOUBLE | 2400 | 2000 | 2500 | 2400  | 2550 | 650  | 750  | 31      | 3600 |



Hydraulic opening of the double side extension  
Reversible version with right/left rolling also



Electro-hydraulic  
unit with  
radio control

# grape trailer

3



ZAM 200 BL

## TWO-WAY DUMPER ZAM 200 BL ZAM 200 BL SUPER

### Standard equipment:

- AISI 304 floureshed stainless steel body.
- Hydraulic two-way tipping system.
- Watertight extension on right side with hydraulic opening and PVC covering.
- Cantilever leaf spring suspensions.
- Regulating connecting rod.
- Braking control system (pneumatic brake).
- Industrial axles (10 studs).
- Self-steering front/rear axle.
- Stainless steel light bar.
- PVC canister H2O. PVC mudguard.
- Hydraulic parking stand. PVC toolbox.

### On demand:

- Hydraulic opening of the double side extension
- Electro-hydraulic unit with remote radio control.
- Stainless steel pull-out middle pole.
- Steering adjuster. PVC manual covering.
- Hydraulic side covering.
- Monitor/camera kit. Special draw bar eye for export.

| MODEL             | BODY SIZE<br>cm | SIDE EXTENSION<br>H cm | HYDRAULIC EXTENSION<br>H cm | VOLUME<br>m <sup>3</sup> | AXLES | TARE<br>tons | GROSS W.<br>Tons | TYRES TYPE          | BRAKE SYSTEM | BRAKE ASSEMBLY     |
|-------------------|-----------------|------------------------|-----------------------------|--------------------------|-------|--------------|------------------|---------------------|--------------|--------------------|
| ZAM 200 BLP       | 550x240x130     | 48                     | 48                          | 18                       | 3     | 4.7          | 20               | 385/55 R22,5<br>new | Pneumatic    | 406x120<br>10 Col. |
| ZAM 200 BLI       |                 |                        |                             |                          |       |              |                  |                     | Hydraulic    |                    |
| ZAM 200 BLP SUPER | 600x240x130     | 48                     | 48                          | 20                       | 3     | 5.0          | 20               | 385/55 R22,5<br>new | Pneumatic    |                    |
| ZAM 200 BLI SUPER |                 |                        |                             |                          |       |              |                  |                     | Hydraulic    |                    |



ZAM 140 BL



ZAM 120 BL  
Hydraulic covering

## TWO-WAY DUMPER ZAM 120 BL / ZAM 140 BL

### Standard equipment:

AISI 304 floureshed stainless steel body.  
Hydraulic two-way tipping system.

**Mod. 120 BL ECO** standard: Manual parking stand, fixed axles, **without hydraulic sides**. Cantilever leaf spring suspensions with rod. PVC mudguard and toolbox. Galvanised light bar.

Other standard models:  
Watertight extension on the right side with hydraulic opening and PVC cover.  
Cantilever leaf spring suspensions with rod.  
Braking system control with pneumatic brakes.  
Self-steering rear axle.  
Stainless steel light bar.  
PVC canister H2O. PVC mudguards.  
Hydraulic parking stand. PVC toolbox.  
Side extension H 48 cm.

### On demand:

Hydraulic opening of the double side extension.  
Electro-hydraulic unit with remote radio control.  
Stainless steel pull-out middle pole.  
Steering adjuster. PVC manual covering.  
Hydraulic side covering.  
Monitor/camera kit. Special draw bar eye for export.  
ZAM 120 ECO hydraulic parking stand.

| MODEL              | BODY SIZE<br>cm | SIDE EXTENSION<br>H cm | HYDRAULIC EXTENSION<br>H cm | VOLUME<br>m <sup>3</sup> | AXLES | TARE tons | GROSS WEIG<br>tons | TYRES TYPE   | BRAKE SYSTEM | BRAKE ASSEMBLY     |
|--------------------|-----------------|------------------------|-----------------------------|--------------------------|-------|-----------|--------------------|--------------|--------------|--------------------|
| ZAM 120 BLP<br>ECO | 450x220x120     | 20                     | -                           | 10,5                     | 2     | 2.6       | 12                 | 385/55 R19,5 | pneumatic    | 300x90<br>8 Col.   |
| ZAM 120 BLI<br>ECO |                 |                        |                             |                          |       |           |                    |              | hydraulic    |                    |
| ZAM 120 BLP        | 450x220x120     | 48                     | 48                          | 13                       | 2     | 2.9       | 12                 | 385/55 R19,5 | pneumatic    |                    |
| ZAM 120 BLI        |                 |                        |                             |                          |       |           |                    | hydraulic    |              |                    |
| ZAM 140 BL45P      | 450x220x120     | 48                     | 48                          | 13                       | 2     | 3.2       | 14                 | 385/55 R22,5 | pneumatic    | 400x80<br>10 Col.  |
| ZAM 140 BL45I      |                 |                        |                             |                          |       |           |                    |              | hydraulic    |                    |
| ZAM 140 BL50P      | 500x240x130     | 48                     | 48                          | 16,5                     | 2     | 3.9       | 14                 | 385/55 R22,5 | pneumatic    |                    |
| ZAM 140 BL50I      |                 |                        |                             |                          |       |           |                    |              | hydraulic    |                    |
| ZAM 140 BLP        | 550x240x130     | 48                     | 48                          | 18                       | 2     | 4.1       | 14                 | 385/55 R22,5 | pneumatic    | 406x120<br>10 Col. |
| ZAM 140 BLI        |                 |                        |                             |                          |       |           |                    |              | hydraulic    |                    |

# grape trailer

5



ZAM 60 BL

Our engineering department designs using 3D software "Grape trailers" personalized models. They are tested according to Italian and European rules.

## TWO-WAY DUMPER ZAM 60 BL

### Standard equipment:

- AISI 304 floureshed stainless steel body.
- Hydraulic two-way tipping system.
- Fixed sides (**without hydraulic two-way side**).
- Stainless steel light PVC canister H20.
- PVC mudguard. Cranking parking stand.
- PVC Toolbox.

### On demand:

- Pull-out middle pipe. PVC manual covering.
- Special draw bar eye for export.

| MODEL      | BODY SIZE<br>cm | SIDE<br>EXTENSION<br>H cm | HYDRAULIC<br>EXTENSION<br>H cm | VOLUME<br>m <sup>3</sup> | AXLES | TARE<br>tons | GROSS WEIG.<br>tons | TYRES TYPE           | BRAKE SYSTEM | BRAKE<br>ASSEMBLY |
|------------|-----------------|---------------------------|--------------------------------|--------------------------|-------|--------------|---------------------|----------------------|--------------|-------------------|
| ZAM 60 BIP | 390x210x120     | 20                        | -                              | 6,5                      | 1     | 1.5          | 6                   | 355/50 R22,5<br>used | hydraulic    | 300x90            |

# grape trailer

6



**ONE AXLE DUMPER**  
ZAM 25/40/50 D  
(from 2.5 to 5.0 TONS)



**ONE AXLE DUMPER**  
ZAM 60/70 D  
(9/12 cubic metres, approved 60 tons)

## Technical data

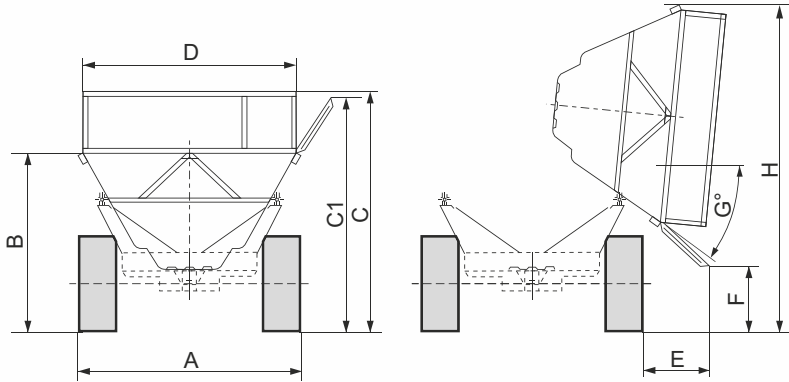

| MODEL<br>Model   | A<br>mm | B<br>mm | C<br>mm | C1<br>mm | D<br>mm | E<br>mm | F<br>mm | G<br>gradi | H<br>mm |
|------------------|---------|---------|---------|----------|---------|---------|---------|------------|---------|
| ZAM 60 BL        | 2050    | 1700    | 1900    | -        | 2100    | 550     | 900     | 32         | 3050    |
| ZAM 120 BL ECO   | 2250    | 1750    | 1950    | -        | 2350    | 450     | 950     | 32         | 3300    |
| ZAM 120 BL       | 2250    | 1750    | 2250    | 2150     | 2350    | 600     | 650     | 32         | 3300    |
| ZAM 140 BL 45    | 2300    | 1800    | 2300    | 2200     | 2350    | 600     | 700     | 32         | 3350    |
| ZAM 140 BL 50    | 2400    | 2000    | 2500    | 2400     | 2550    | 650     | 750     | 31         | 3600    |
| ZAM 140 BL       | 2400    | 2000    | 2500    | 2400     | 2550    | 650     | 750     | 31         | 3600    |
| ZAM 200 BL       |         |         |         |          |         |         |         |            |         |
| ZAM 200 BL SUPER |         |         |         |          |         |         |         |            |         |



ZAM 120 /140 2A with stainless steel removing vat



**TWO AXLES  
TRAILER  
FIFTH WHEEL**  
(from 12.0 to 14.0 tons)

# ZACCARIA

QUALITY TRAILERS



zaccariarimorchi.com



ZACCARIA SRL

Via Enrico Fermi, 350

I - 41055 Montese (Modena) - Italy

Tel. +39 (0)59 981750

Fax: +39 (0)59 982353

www.zaccariarimorchi.com

info@zaccariarimorchi.com

 [www.facebook.com/zaccariarimorchi](http://www.facebook.com/zaccariarimorchi)

 [www.linkedin.com/company/zaccaria-srl](http://www.linkedin.com/company/zaccaria-srl)

 [www.youtube.com/channel/UCe9-IOXLYuqygcinU1n51jA](http://www.youtube.com/channel/UCe9-IOXLYuqygcinU1n51jA)



scansiona il QR CODE  
per visualizzare  
i nostri VIDEO  
zaccaria trailers youtube

## Subsidiaries and Warehouses

I - 41015 Nonantola (Modena)

Via Zuccola, 12 - Italy

I - 41057 Spilamberto (Modena)

Piazza Beccadori, 4 - Italy

