



Crop Protection



You can find the current status of the certified functionalities* in the AEF database.

Table of contents

Function overview	Page	3
ISOBUS SPRAYER-Controller	Page	4
TANK-Control	Page	6
TANK-Control III	Page	7
DISTANCE-Control I and II	Page	8
TRAIL-Control	Page	9
SECTION-Control TOP	Page	10
MULTI-Control	Page	12
ME-Configurator	Page	14
SPRAYDOS	Page	16
SECTION-Control BOX	Page	17
SPRAYMAT II	Page	19
Accessories	Page	19

All information about the company and the products can be found here:



www.mueller-elektronik.de



shop.mueller-elektronik.de



www.facebook.com/me.salzkotten

AEF Certified

ISOBUS

www.aef-isobus-database.org

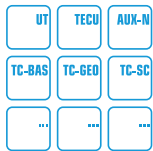

ME job computers comply with ISOBUS standard 11783 and are AEF-certified. You can find the current state of the certified functionalities* in the AEF database.

* subject to change

Function Overview

Application rate monitoring
Application rate regulation
ISOBUS system
No. of sections
Hydraulic functions
Trip and total counter
Task Management (ISOBUS-TC)
Working with prescription maps
Fill level sensor(TANK-Control)
Filling, rinsing and stirrer control(TANK-Control III)
Drawbar and stub axle steering(TRAIL-Control)
Boom height control system(DISTANCE-Control)
Boom height control system(DISTANCE-Control II)
Section control (SECTION-Control)
Single nozzle switching (SECTION-Control TOP)
Automatic nozzle selection(VARIO-Select)
Turn Compensation (CURVE-Control)
Droplet size control (AIRTEC)
Multi-product control (MULTI-Product)
Multi-device control (MULTI-Device)
Multi-boom control (MULTI-Boom)
Rate control per section (MULTI RATE-Control)
Multi-boom section control (MULTI SECTION-Control)
External keypads
Joystick
S-Box
Weather Station
Compatibility with agronomic sensors
Configuration

MIDI 3.0	SPRAYDOS long	SPRAYDOS short	SPRAYMAT II
x	x	x	x
x	x	x	-
x	-	-	-
up to 18 (with 2 job computers)	9	9	-
up to 20 hydraulic functions per job computer	13	4	-
x	x	x	x
x	via SC-BOX	via SC-BOX	-
x	via SC-BOX	via SC-BOX	-
x	x	x	-
x	-	-	-
x	-	-	-
x	-	-	-
x	-	-	-
x	via SC-BOX	via SC-BOX	-
up to 512	-	-	-
x	-	-	-
x	-	-	-
x	-	-	-
x	-	-	-
x	-	-	-
x	-	-	-
x	-	-	-
x	-	-	-
up to 3x 8 keys	-	-	-
x	via SC-BOX	via SC-BOX	-
x	via SC-BOX	via SC-BOX	-
x	via SC-BOX	via SC-BOX	-
x	via SC-BOX	via SC-BOX	-
via PC	not necessary	not necessary	not necessary

ISOBUS SPRAYER-Controller

The ISOBUS SPRAYER-Controller is setting new standards in the area of sprayer control systems. Depending on the implement equipment, the systems can be extended with an additional job computer. The assignment can be configured individually.

The standard configuration of the ISOBUS SPRAYER-Controller has 9 sections and up to 5 hydraulic functions. The system can be extended to include up to 8 MIDI job computers.



Functions



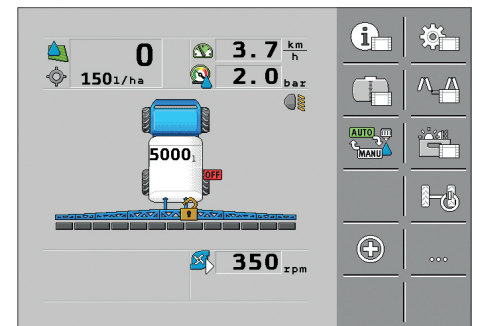

With their individual configuration options, the MIDI 3.0 job computer can be adapted to virtually any sprayer functionality:

- Application rate control via flow metre and/or pressure sensor
- Control of bypass valves and ring line circulation systems
- Internal task counter
- Fill level measurement with fill stop (TANK-Control)
- Control of all hydraulic functions (e.g. boom folding)
- Automatic boom control (DISTANCE-Control I and II)
- Automatic stub axle or articulated drawbar steering (TRAIL-Control)
- Section control for up to 18 sections (SECTION-Control)
- Possible integration of external controls (joystick, S-BOX, keypads)



Profile of a self-propelled sprayer

Work screen display with the buttons for the respective sub-menu levels:

-  Info button for the internal counters
-  Filling screen
-  Settings screen
-  Folding screen
-  Special functions

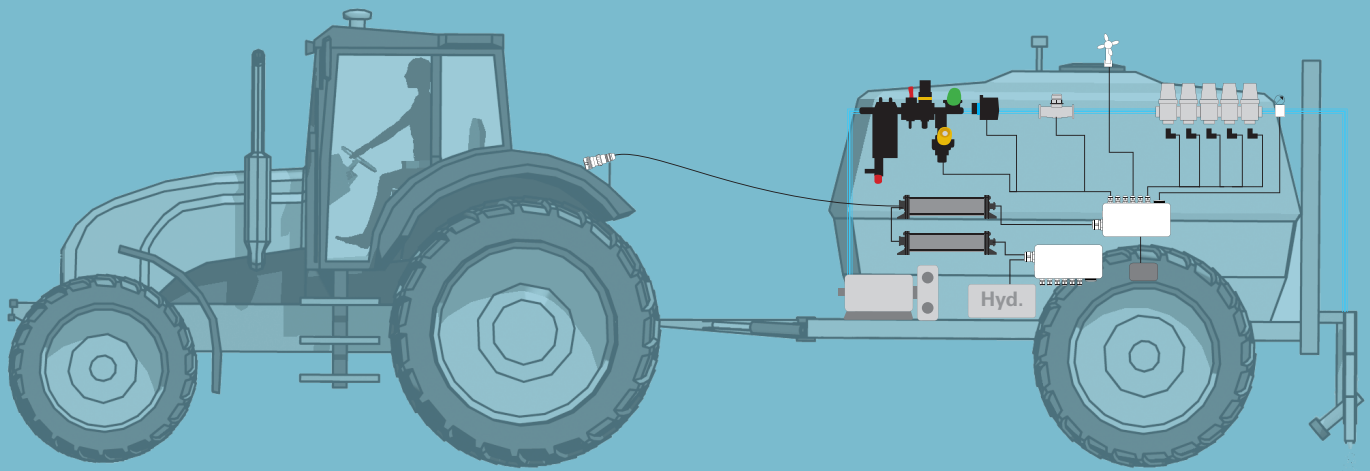

The user interface is modern, intuitive, and fits seamlessly in the ME family. The implement types, displays and colours can be adjusted according to the manufacturer's requirements. All icons and controls can also be positioned individually on the screens.

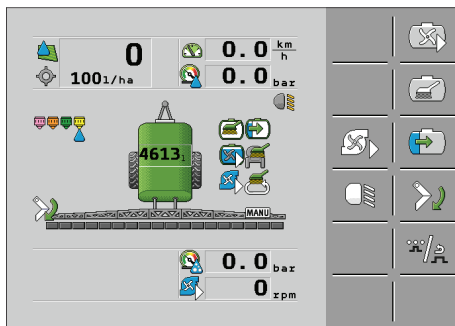

Profile of a trailed sprayer

Display of the special functions menu level. Functions that are already activated are shown as icons on the screen:



Working lights



External cleaning

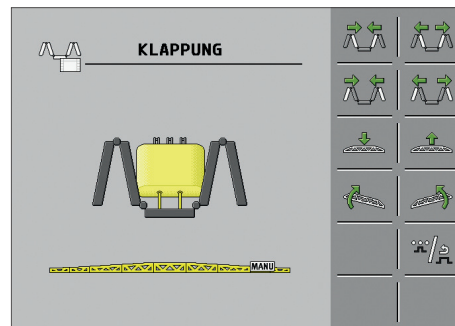

Profile of a mounted sprayer

Display of the boom folding menu level:

- Fold and unfold inner boom sections
- Fold and unfold outer boom sections
- Lift and lower the boom
- Slope boom to the right and left

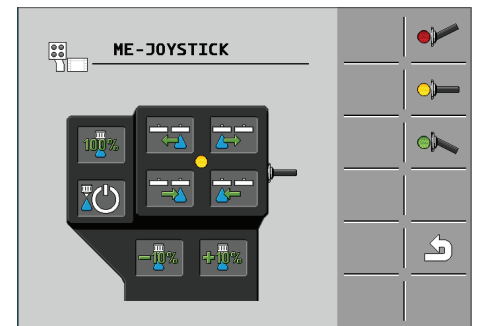

ISOBUS joystick for controlling the sprayer functions

Display of the button assignment as a help function on the job computer screen. All of the buttons can be freely assigned by the manufacturer. Through the support of AUX-N functionalities, the tractor driving lever can also be used to control the implement.

Advantages

- Flexible configuration of inputs and outputs
- Cascadable hardware
- Diagnosable inputs and outputs (via CAN or Wi-Fi)
- Customer-specific user interface organization

TANK-Control

The TANK-Control fill level measuring system enables the precise display of the tank content for sprayers, and also automatic fill stop when reaching a previously set quantity. The measured values, i.e. the tank content, can be read both on the TANK-Control display on the sprayer tank and on the terminal in the tractor. It is primarily intended for use with liquid fertilizers and in crop protection. The sensor works with all liquid solutions, even at specific densities different from that of water.



Functions

Magnetic field-dependant sensors are installed inside a stainless steel tube. A floater with permanent magnets switches one of the sensors according to the fill level. The stainless steel tube is installed vertically in the middle of the tank to compensate for slopes. Each fill level only needs to be calibrated and assigned to a tank content once. This makes it possible to determine the level even in irregularly shaped tanks.

The desired tank table is activated through a simple selection on the keypad. Unknown tanks, e.g. when retrofitted, can be easily calibrated using a water meter.

TANK-Control is offered in 5 lengths: Measurement heights up to 1200 mm, 1440 mm, 1600 mm, 1840 mm and 2080 mm. The illustrated control element is installed near the filling point. The tank content is constantly displayed. When the pre-selected quantity has been reached, the filling procedure can be automatically terminated by means of a ball valve. During operation, the tank content and the area and distance that still need to be applied are displayed in the tractor cab.

Fill level sensor

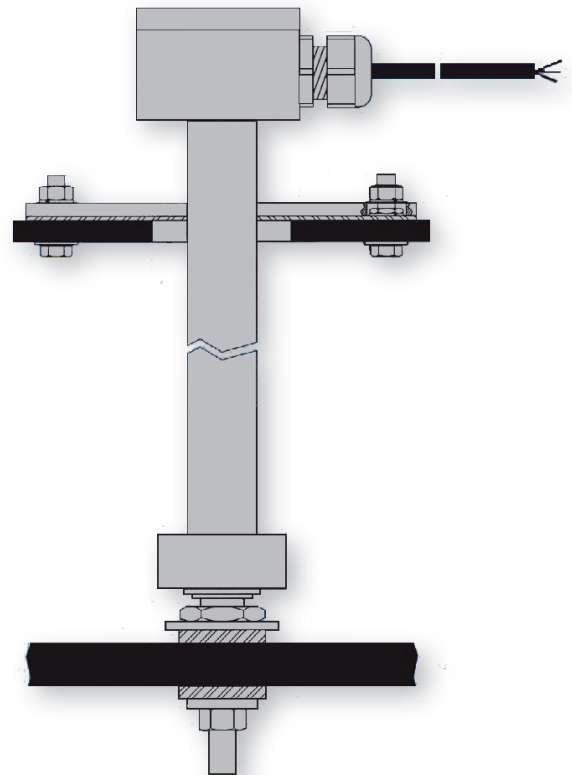

Advantages

- Exact tank content display on the implement and in the cab
- Display of the remaining quantity and the area that still needs to be applied with it
- Warning tone when the set minimum quantity has been undercut
- Automatic fill stop
- Also suitable for liquid fertilizer

Optional fill level display for TANK-Control II



TANK-Control III

TANK-Control III is a system for controlling electric valves and enables the integration and regulation of stirrers and rinsing processes for sprayers. Moreover, two TANK-Control sensors can be connected for measuring the tank content and for the fill stop.

TANK-Control III is an ISOBUS application that is either part of the SPRAYER-Controller or used as a separate job computer. The TANK-Control III terminal also complies with environmental protection classes IP69 (acc. to DIN EN 60529) and offers a high contrast 4.3" colour display. It is therefore ideal for outdoor use and can be easily read.

All information on the implement and on the TANK-Control system are available anywhere. This makes it possible not only to read the tank content at the filling point, but also the remaining area to be applied and the resulting required refill water quantity. When entering the area to be applied with the corresponding target rate, the system automatically calculates the required water or refill quantity. This makes the filling procedure easier for the operator and reduces residual quantities to a minimum. Furthermore, the rinsing processes can be controlled from the filling point.

Work screen



Filling screen 1



Advantages

- Waterproof display for operation outside the cab
- Infinitely variable fill level measurement on up to two tanks
- Switching and regulating of stirring or filling procedures
- Reduction of residual quantities to a minimum

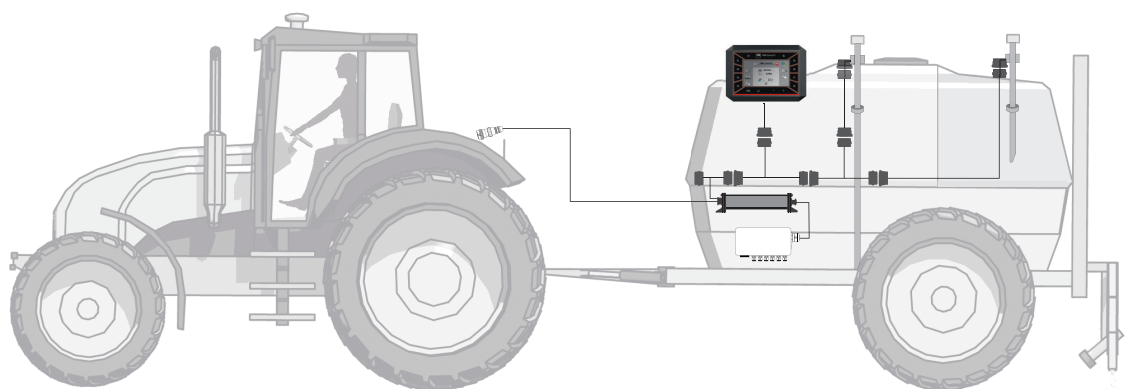

DISTANCE-Control I and II

With DISTANCE-Control, Müller-Elektronik offers a distance regulation system for field sprayer booms. Ultrasonic sensors measure the distance from the plant canopy, which is then controlled by the sprayer hydraulic system. Depending on the boom design and hydraulic equipment, either DISTANCE-Control I or DISTANCE-Control II is used.

DISTANCE-Control I

is capable of regulating the boom height and the boom slope. The system consists of at least two ultrasonic sensors, one slope sensor and an angle sensor. It is controlled using the standard hydraulic system. The slope can also be adjusted using an electric linear actuator.

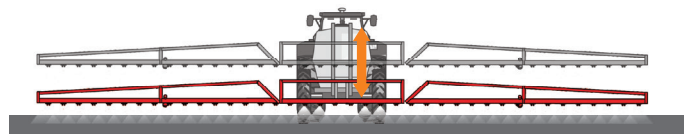
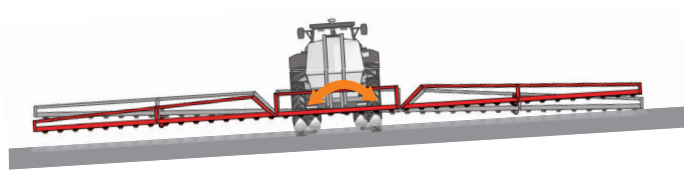

DISTANCE-Control II

enables additional active and individual control of the boom arms. This means that the arms can be tilted both upwards and downwards independently from one another using hydraulic cylinders. The boom is controlled by means of proportional valves.

An ultrasonic sensor is mounted both on the boom arms and on the central part. The position and the angle of the boom arms are determined by a potentiometer or by means of integrated measurement systems in the hydraulic cylinders. The control of all boom parts achieves absolute high-precision distance regulation, even on very hilly terrain.

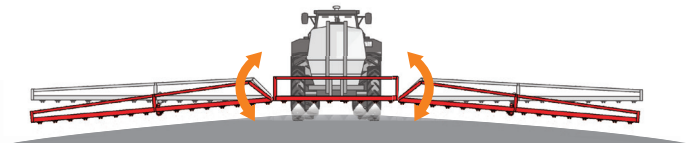

Advantages

- Automatic height and slope adjustment
- Accurate application distances
- Prevention of boom damage
- Prevention of drift through precise application height



ISOBUS TRAIL-Control

ISOBUS TRAIL-Control ensures automatic tracking of trailed implements (with folding drawbar or stub axle steering) in the tractor track. The implement can also be driven offset to the tractor (crab steering) both on slopes and on level terrain. ISOBUS TRAIL-Control therefore reduces crop damage and increases yields.

ISOBUS TRAIL-Control is available as a stand-alone ISOBUS version as well as integrated into the ISOBUS sprayer application.

Functions

A sensor on the tractor and a sensor on the three-point hitch of the machine steering determine the actual status of the overall system. Based on the current forward speed, the computer adjusts the required reaction of the hydraulic system. A slope sensor can be integrated as an option. It provides information on the slope of the terrain. Semi-automatic slope countermeasures can thus be implemented.

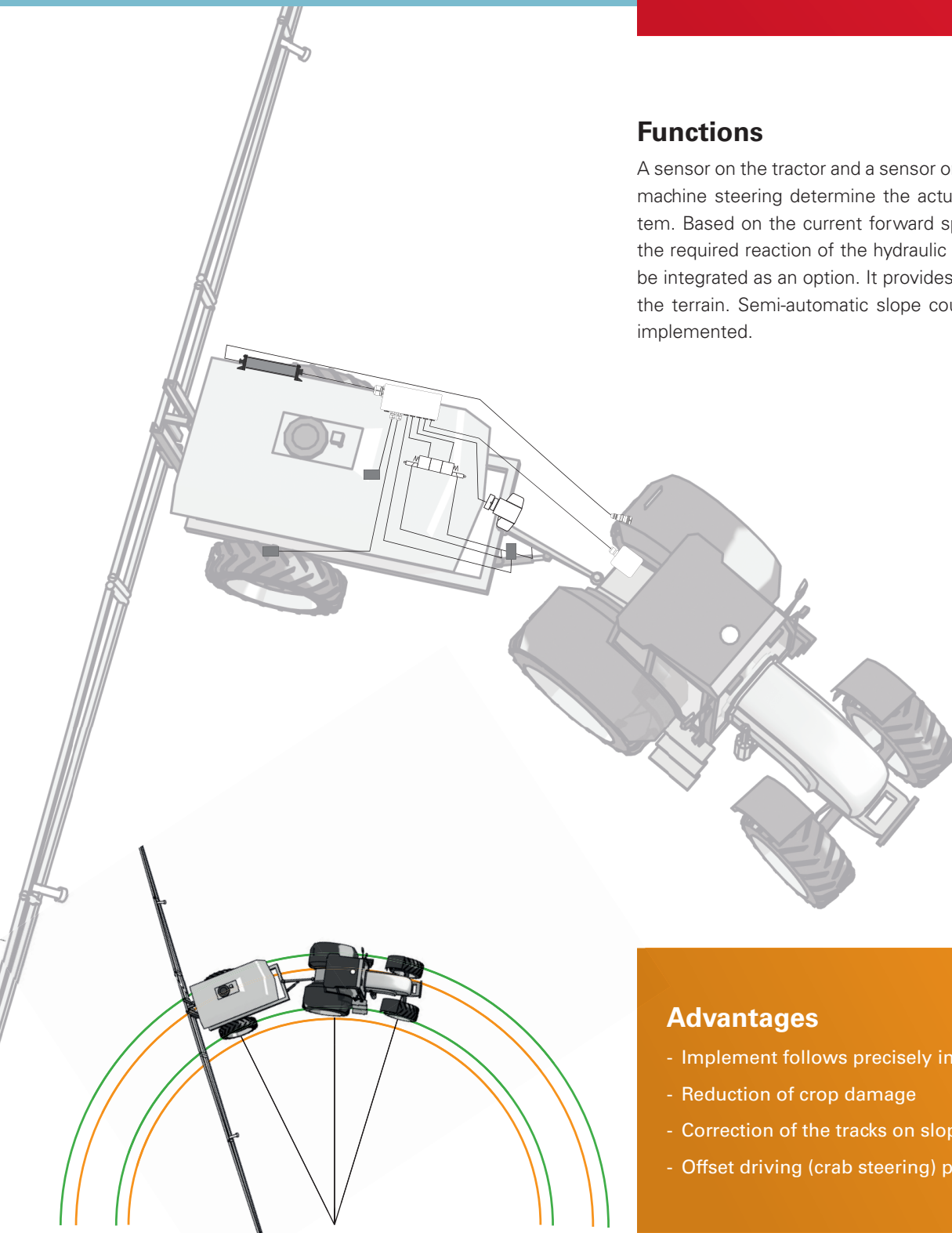

Advantages

- Implement follows precisely in the tractor track
- Reduction of crop damage
- Correction of the tracks on slopes
- Offset driving (crab steering) possible

SECTION-Control TOP

SECTION-Control TOP is the single nozzle control system manufactured by Müller-Elektronik. With this solution, it is not only possible to control each section, but also each nozzle can be individually and precisely switched on and off through GPS control. This increases the efficacy, reduces overlaps to a minimum, and makes a significant contribution to reducing costs and protecting the environment.

Another great advantage of SECTION-Control TOP is the combination with VARIO-Select. This combination enables the largest possible application range or higher working speeds at a constant drop size.

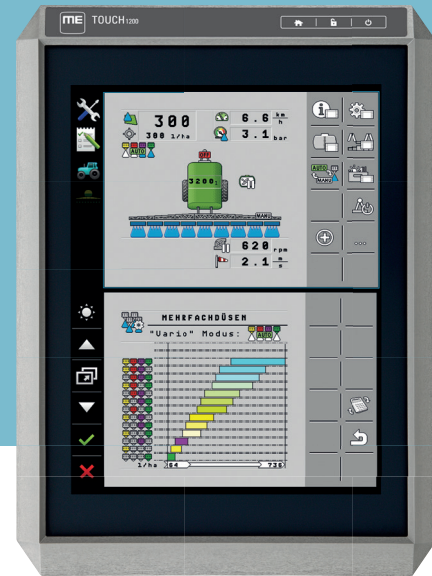

Functions

In addition to a ISOBUS SPRAYER-Controller, the system includes both a communication module and the corresponding pneumatic EDS modules. With each module, either four single, two double or one quadruple nozzle holder can be controlled. The EDS modules are simply attached onto the nozzle tube and connected with each other in series. Then only the nozzle holder still has to be pneumatically connected. The system automatically detects the position of the nozzles on the boom.

SECTION-Control TOP can also be used as an inexpensive alternative for section control. Its advantages include flexible organization of the sections, simple upgrading all the way to single nozzle switching, and cost reduction since the manifold is not required and the installation is simple and standardized.

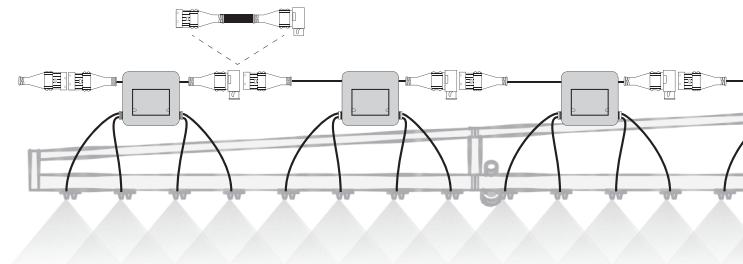

Maximum savings potential

GPS-controlled switching and the accuracy of the system result in a reduction of the total overlap to less than 1%. Product savings of 10 to 15% as well as user-friendliness and relief of the user are additional advantages of the system.

Advantages of SECTION-Control TOP

- Maximum precision
 - Maximum performance
 - Maximum savings
 - Maximum flexibility
 - Maximum user friendliness
- ...for maximum success!

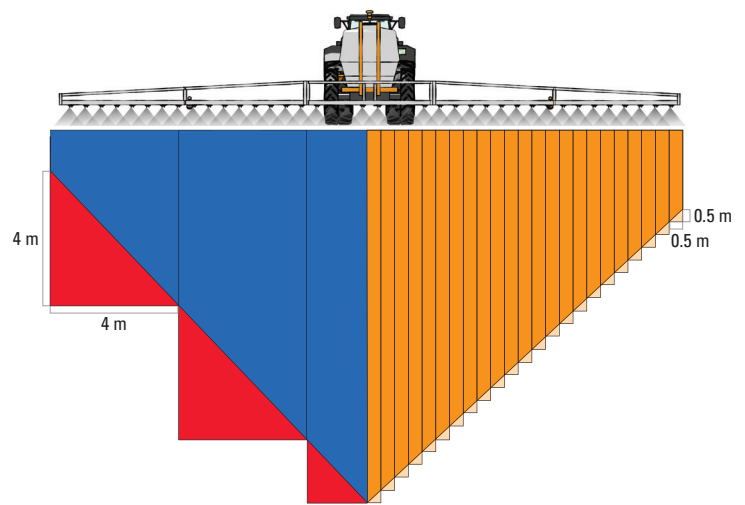

=> 40 m² overlap area

=> 5 m² overlap area

From section control through individual nozzle switching all the way to VARIO-Select

Individual nozzle switching with VARIO-Select

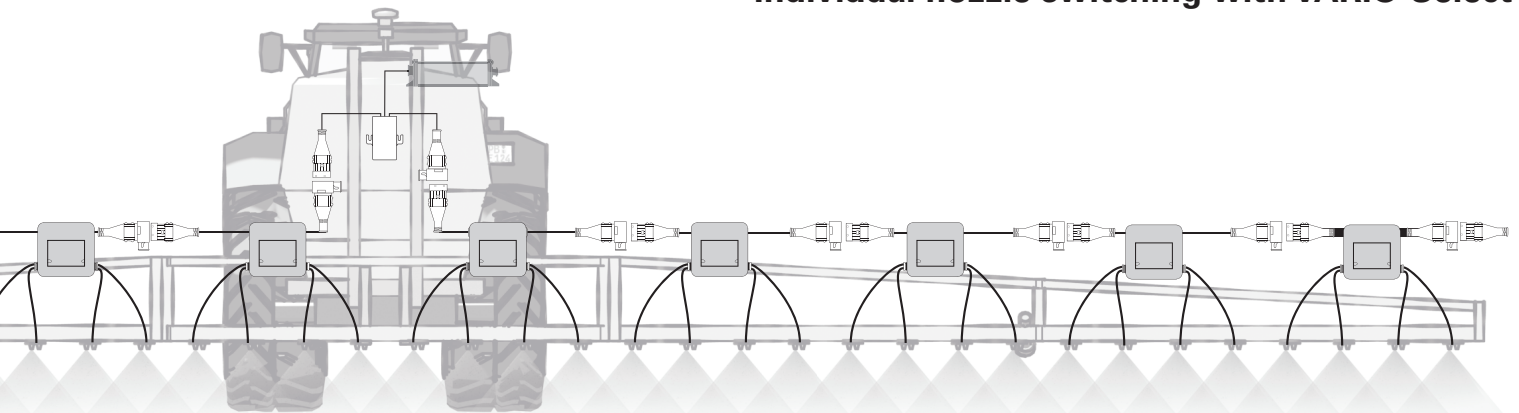

VARIO-Select

VARIO-Select enables fully automatic switching and optimum control during application with bigger or smaller nozzles or nozzle combinations, and constant pressure adjustment for infinitely variable adaptation of the application rate (e.g. 50 – 600 l/ha) to site-specific target rates (e.g. UAN, growth regulators). Further-

more, VARIO-Select guarantees both a constant application rate (l/ha) and a uniform drop size with greater variability of the forward speed (e.g. hilly terrain). In addition, VARIO-Select represents the technical basis for CURVE-Control and MULTI-Rate.



Advantages of VARIO-Select

- No conversion of the nozzle holders required
- Greater application range
- Higher working speed with constant drop size
- Uniform application rates even when manoeuvring curves (CURVE-Control)
- Individual application rate for each section (MULTI-Rate)

MULTI-Control

Modern agricultural implements are becoming increasingly complex. Seeders apply seed and fertilizers simultaneously in one operation, and fertilizer spreaders are capable of applying up to four individual nutrients in one field pass. Sprayers with two booms and the corresponding circulation systems for different substances must be regulated by only one terminal.

With MULTI-Control by Müller-Elektronik, this complexity is now possible with all TOUCH terminals. To achieve this, the ISOBUS Task Controller was extended with the various MULTI-Control functions through special adjustments. Depending on the specific application situation and the implement equipment, the following functionalities are possible: MULTI-Product, MULTI-Rate, MULTI-Boom, MULTI-Device or MULTI-SECTION-Control



with CURVE-Control

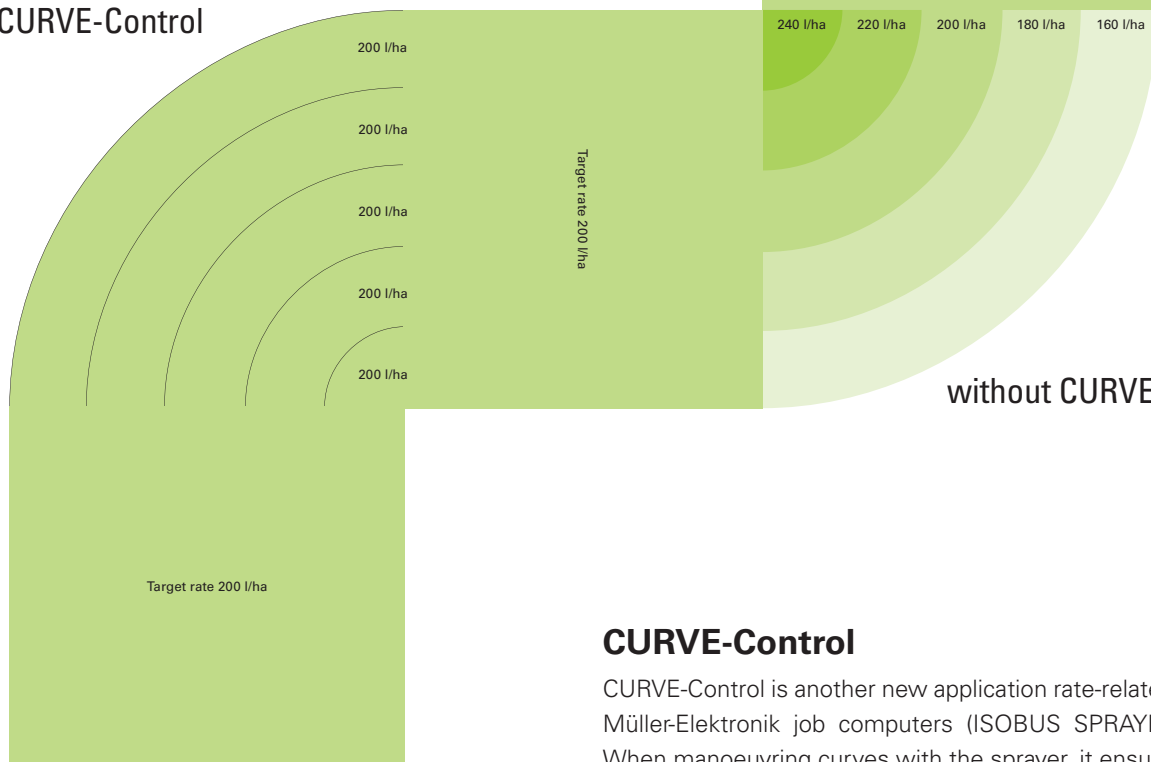

Advantages

- Highly precise application
- Reduction of crop damage
- Saving of resources
- Precision farming in a class of its own

CURVE-Control

CURVE-Control is another new application rate-related function for Müller-Elektronik job computers (ISOBUS SPRAYER-Controller). When manoeuvring curves with the sprayer, it ensures a constant application rate both in the outer and inner areas.

This is made possible by switching different nozzle combinations on each section. A switchable multiple nozzle holder and the VARIO-SELECT licence are required. Using a GPS receiver, the Müller-Elektronik terminal transmits the precise position of the boom to the field sprayer job computer. The job computer determines the speed and the curve radius by means of sensors and then calculates the corresponding target rate per section. The system automatically adjusts the rate on each section by switching different nozzle combinations.

MULTI-Rate

The benefits of MULTI-Control for agricultural practice can be clearly illustrated using the example of a sprayer. MULTI-Rate makes it possible to transmit multiple target rates simultaneously using the Task-Controller. When using prescription maps in precision farming, the target rate can be regulated accordingly for each section. Until now, it was only possible over the entire boom width of the sprayer. This function can also be used with the online method by means of N-Sensors.

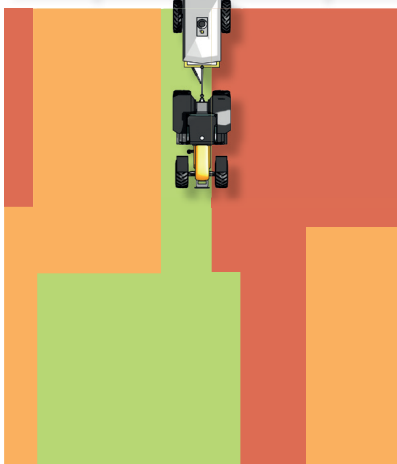
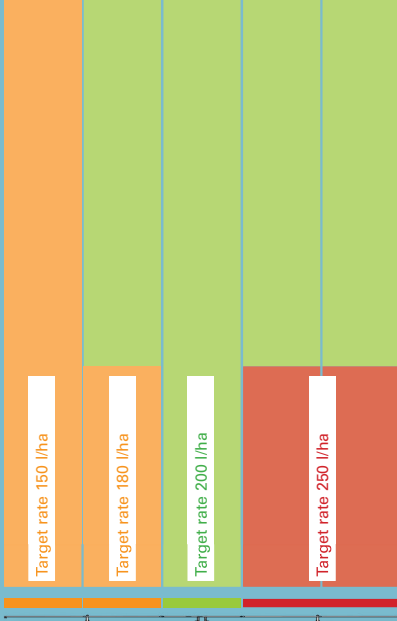

Sprayer with dual tank system and two booms with individual circulation systems

MULTI-Boom

Two booms with different application points

MULTI SECTION-Control

Each boom and each section is switched based on its own position

MULTI-Rate:

Variable application rate for each section

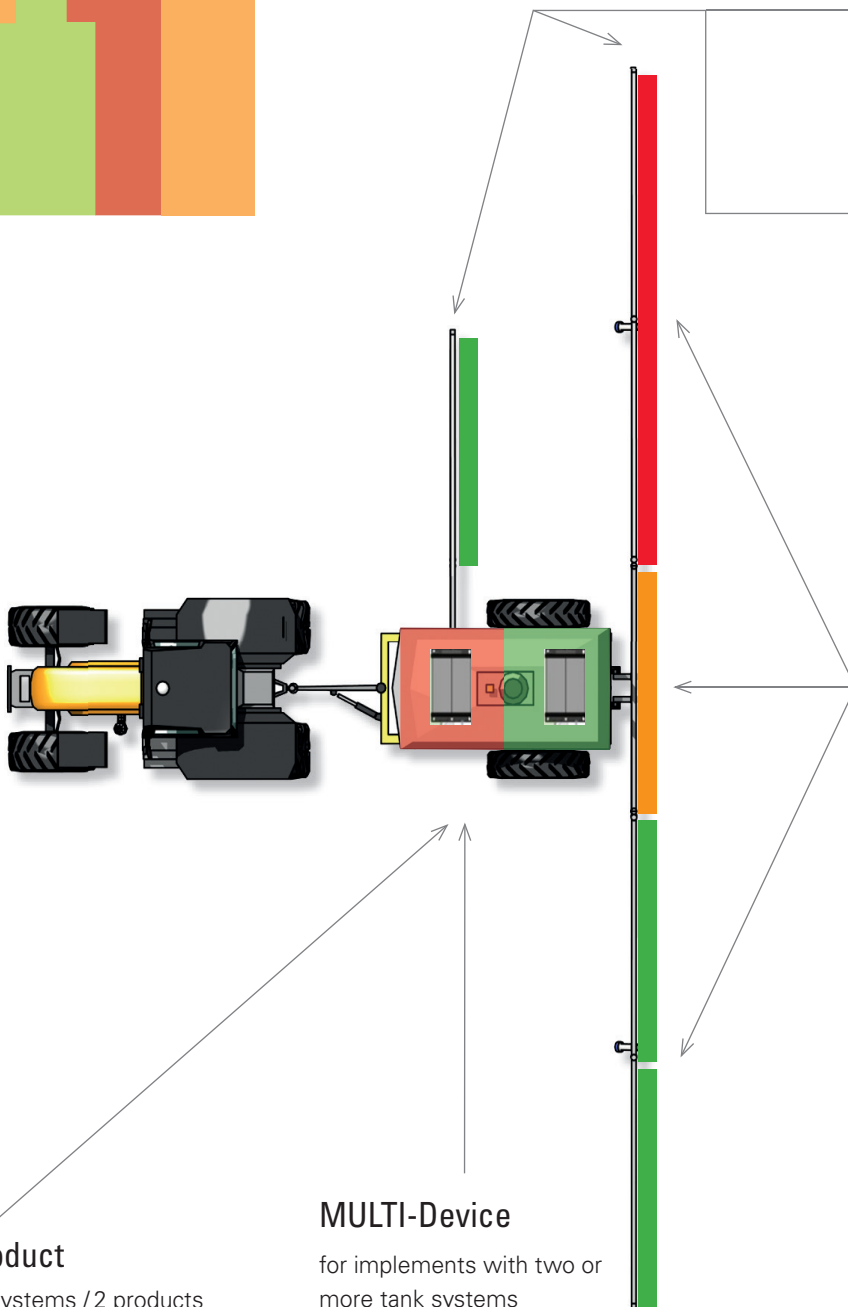

MULTI-Product

2 circulation systems / 2 products

MULTI-Device

for implements with two or more tank systems

ME-Configurator for ISOBUS SPRAYER-Controller

The ME-Configurator is a user-friendly software tool that serves to configure the scope of functions on a sprayer. The clear and intuitive menu structure makes it easier for the user to set up the implement. Data exchange between the PC and job computer is bidirectional. Thus, it is possible to transfer a previously created configuration file from the PC to the job computer or to transfer it from a ME terminal to the job computer via a USB memory device. This simplifies e.g. the use in the end-of-line production. The configurator is also very practical for servicing. In this case, the functions and work screens can be edited directly on the implement.

Functions

The ME-Configurator can be used with different authorizations, the expert mode for unrestricted use is usable after extensive training by Müller-Elektronik.

In the respective menus, the implement functions can be selected and the corresponding inputs/outputs on the job computer can be activated. The assignment to specific hydraulic blocks (pre-switch valve/A/B logic) can be done in advance.

The terminal display can be adapted to the individual needs, soft-keys and screen elements can be arranged simply by drag and drop on the display. In the same way, the individual function levels of the joystick can also be pre-assigned.

The sequential procedures for the mounted implement and the required functions and time sequences can be fully planned in advance. All of the parameters that are already known, such as the pulses/100m or the geometry, can be easily entered on the PC.

Advantages

- Easier configuration for end-of-line production
- Comfortable use for service
- Always current due to regular updates
- Full flexibility in expert mode

Selection of the machine type

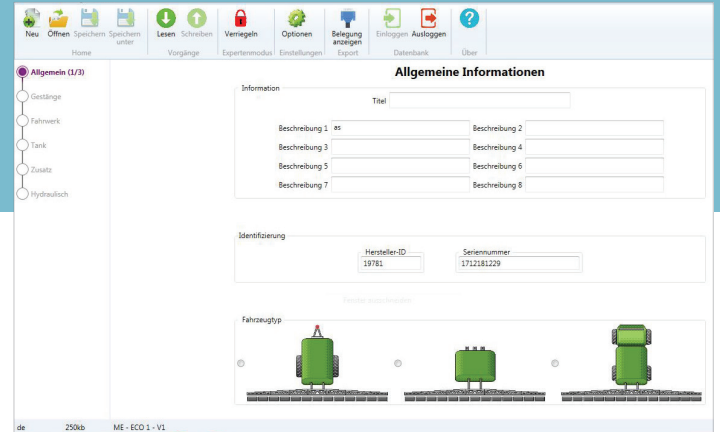

Configuration of the boom functions

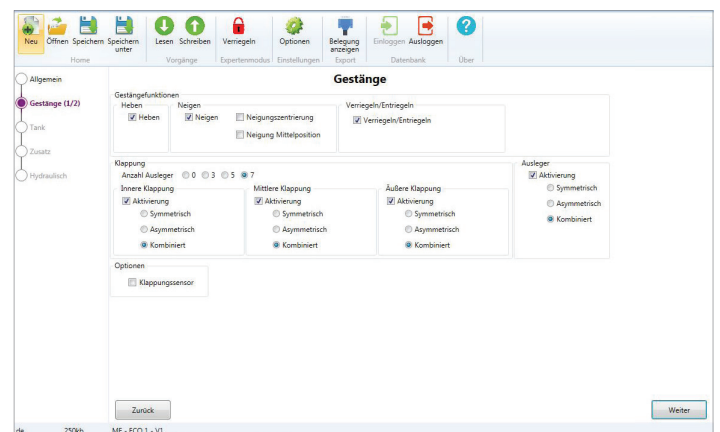

Assignment of the joystick

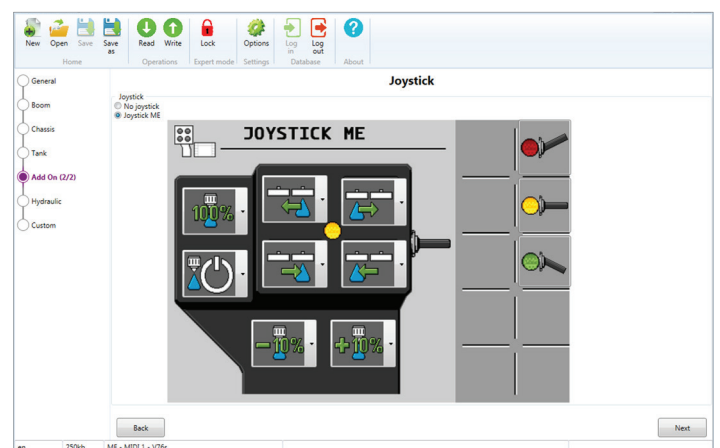



SPRAYDOS

The SPRAYDOS is a fully automated control unit for field sprayers and orchard sprayers. It excels with its robust aluminium casing and user-friendliness, and starts work at the press of a button. The device is available both as a "short" and a "long" version, and both support up to 9 sections and TANK-Control as a standard. By retrofitting the SECTION-Control BOX and a Müller terminal, both SECTION-Control and other functions can be added.



Functions

In terms of the basic principles, the short and the long SPRAYDOS are identical. Both versions offer manual and automatic regulation of the application rate and up to 4 double-acting hydraulic functions.

The current speed and current application rate are shown simultaneously on the display. If an electronic pressure sensor is installed, the pressure is displayed instead of the speed. Customized applications can be activated by pressing the +/- 10 % buttons.

Furthermore, the SPRAYDOS offers up to 9 section controls with main switch.

The "long" SPRAYDOS provides another 9 double-acting hydraulic functions, e.g. for edge nozzles, foam marker, boom functions and drawbar steering.

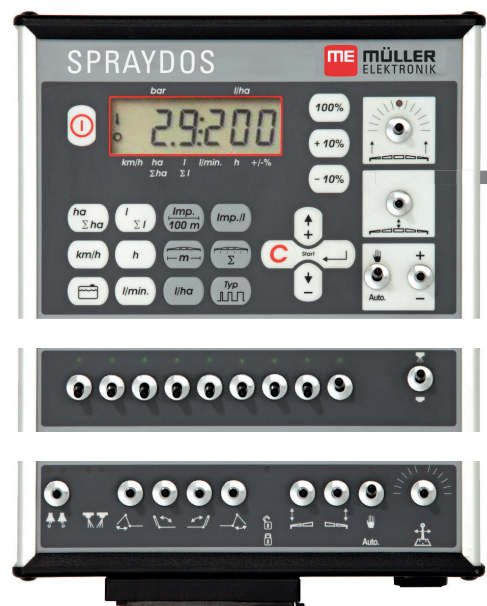

Advantages

- Easy to operate
- Automatic application rate regulation
- Display of the pressure, speed and application rate
- Temporary rate changes with +/- buttons
- Alarm when deviating from the target rate
- SECTION-Control can be retrofitted

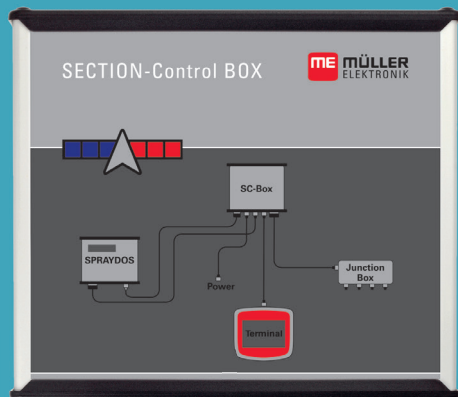

SECTION-Control BOX

The SECTION-Control BOX (SC-BOX) is the convenient retrofit solution for GPS-based section control on simple sprayers. In addition to the SECTION-Control function, the SC-BOX also provides the option of connecting the ME joystick or S-BOX. A Müller terminal is required along with the SC-BOX. Everything is simply connected by plug connections. Soldering or conversion is not necessary!

SECTION-Control via SC-BOX

The sprayer is easily and conveniently retrofitted per "plug and play". The original implement cable harness is maintained, only the SC-BOX and the ME terminal are added. The SC-BOX now takes care of regulating the sprayer. The hydraulic functions remain on the original operating device.

With the SC-BOX and the ME terminal, your field sprayer is upgraded with state-of-the-art technology. You gain access to all "APP & GO" precision farming applications. This enables the use of prescription maps or online sensors via ISOBUS. Tasks can be planned and documented with the ISOBUS-TC app.

In addition to Müller-Elektronik systems such as SPRAYDOS, UNI-Control S and SPRAY-Control S, third-party products can also be easily retrofitted. You can find more information on this on the website www.sc-box.de

Advantages

- Easy and quick installation
- Update to state-of-the-art technology
- Profitable already starting at a few hectares
- Saves time, money and resources
- Joystick and S-BOX

SPRAYMAT II

The SPRAYMAT II is a proven monitoring and display device for more simple sprayers. The operation is extremely basic, work can begin at the push of a button. The SPRAYMAT II displays both the current application rate and the current speed.

Furthermore, the device can be used throughout the year as a hectare counter with speed display and RPM monitoring on a wide range of different implements.



Use as a hectare counter

In addition to the listed functions, particularly precise determination of the area is achieved through:

- Automatic forward/reverse detection
- Adjustment for partial working widths by pressing a button

Advantages

- Easy and logical operating procedures, only one button must be pressed to begin work
- Constant display of the current speed and application rate (l/ha), can be read at a glance
- Cost reduction and conservation of the environment through precise application rates and low residual quantities
- Use on mechanical, electro-magnetic, electro-motive and pneumatic manifolds
- Adjustment for partial working widths by pressing a button.

Technology

- Clearly arranged, resistant membrane keypad with tactile feedback
- Determination of the single area, total area (e.g. season) applied spray liquid, total applied spray liquid, working time, current application rate, area output and speed
- Robust plastic casing
- Large illuminated LCD display. The displayed function is marked with an arrow at the bottom edge of the screen.
- Function check for the sensors, displayed on the screen
- Central plug: easy and uncomplicated sensor connection
- Self-test when switching on
- Storage of all determined and entered data even when the device is switched off
- "Distance" pulse recording from the drive shaft, wheel, speedometer cable or signal socket on the tractor
- Adaptation to different types of fittings
- Standard flow meter from 6 l/min to 140 l/min
- Other flow meters from 0.5 l/min to 1000 l/min in the pressure range up to 30 bar
- RPM display and monitoring from 20 to 10000 rpm
- Integration of up to 8 sections for determining the area and application rate, Automatic conversion to the full working width at the end of the field
- Easy conversion of the computer for a different implement in just a few minutes. This ensures optimal use of the device.

PRECISION FARMING ACCESSORIES



External keypad

The CAN keypad offers protection class IP69K and can therefore also be used e.g. on the outside of the sprayer. The keys are illuminated in colour and can also be operated in the dark. With the corresponding cable harness, these keypads are connected directly to the CAN Bus of the job computer.



ISOBUS Weather Station

The Müller-Elektronik weather station is the first ISOBUS weather station on the market. The sensor informs you immediately about changes in the wind speed and direction, air humidity and pressure, temperature and evaporation rates (Delta T). The weather conditions can also be saved by the ISOBUS Task-Controller for documentation purposes if required.



ISOBUS joysticks

The ISOBUS joystick is a "must" as optional equipment for any implement control unit. It facilitates operation so the driver can concentrate on production processes. The joystick can be retrofitted on almost any tractor and is easy to install. Thanks to the AUX-N functionality, the buttons can be individually assigned. In addition to the functions provided by the ISOBUS joystick, the ISOBUS joystick PRO is also mobile and can be controlled via two proportional axes. This considerably facilitates the control of certain functions, such as, for example, the adjustment of the filling arm when filling a slurry tanker. The ISOBUS joystick PRO complies with the AUX-N standard of the ISOBUS standard and supports the corresponding functions of the machine.



S-BOX

The S-Box is an additional module for sprayer control. It can be installed directly under the terminal and facilitates the manual switching of individual sections. Ideal for localized treatment and available for implements with up to 18 sections.



Agronomic sensors

Agronomic sensors play an important role in precision farming. ISOBUS sensors, such as the CLAAS CROP sensor, are easy to handle because they login to the BUS system and can be controlled. Non-ISOBUS sensors, like the YARA N sensor, can be connected to the Müller-Elektronik control terminals either through (its own) integration or the serial interface.

Müller-Elektronik GmbH & Co. KG

Franz-Kleine-Straße 18 . 33154 Salzkotten . Germany
Tel. +49 5258 9834-0 . Fax +49 5258 9834-90
info@mueller-elektronik.de . www.mueller-elektronik.de

04/2018, subject to change.

Your local dealer: