



**BARGAM**<sup>®</sup>  
Agriculture

## MAINTENANCE & USE OPERATOR'S MANUAL



### SHREDDER



Keep this manual throughout the life of the machine it refers to.

© 1997 . It is forbidden to reproduce and/or to make this document public, in any form, without written consent from the author. Information and technical data have been provided, checked and validate by the BGROUP S.P.A. technical office.  
The text, illustrations and layout have been made under the supervision of the BGROUP S.P.A. technical office.

**BARGAM**<sup>®</sup>  
Agriculture

Equi marchio della **BGROUP S.P.A.**  
**Bgroup. Sede legale e operativa/Registered Office and Production Plant:**  
Via della Cooperazione, n.20 40026 IMOLA (BO) ITALY  
Tel. +39 0542 648539 - website: [www.Bgroup.info](http://www.Bgroup.info) email: [info@bgroup.com](mailto:info@bgroup.com)  
Reg. Impr./ Cod. Fisc./ P.IVA 01463360436 (VAT IT 01463360436)

## Warranty.

- a) Within the limits of the following provisions, BGROUP S.P.A. undertakes - exclusively with respect to the Purchaser - that the goods being sold are exempt from vices of material, design, manufacturing and assembly relating to the level of technology available at the time of the manufacturing of the product. Said obligation is limited to the defects occurring during the period of 12 months from the delivery to the Purchaser of the products.
- b) Provided that the warranty lasts one year (12 months), the warranty start date may be postponed up to a maximum of six months with respect to the delivery date of the good from BGROUP S.P.A. to the Purchaser when, for any reason, the Purchaser or its assignee cannot sell and deliver the purchased goods to third parties. In this case, the warranty becomes effective from the moment in which the Purchaser has delivered the machine to the third party. The Purchaser itself shall directly notify BGROUP S.P.A. about the performed delivery of the product to the end User. Said obligation shall be considered fulfilled when the Purchaser sends to BGROUP S.P.A. the special Warranty Certificate, contained in the Instructions for use + Manual of BGROUP S.P.A., which the latter had delivered to its counterpart upon machine delivery. In any case the warranty granted by BGROUP S.P.A. is valid and effective always and only towards the direct Purchaser, and cannot be enforced by the latter after 18 months have elapsed from goods receipt.
- c) BGROUP S.P.A. does not guarantee manufacturing vices and/or defects of engines, diesel mechanisms and equipment, electric and thermal devices (e.g. tyres, fuel injector, engine, differential unit, bearings, oil-pressure components, etc.) which are sold individually or simply assembled by BGROUP S.P.A., but manufactured by other companies and, in this case, BGROUP S.P.A. restricts itself to sending the Purchaser the warranties issued by those manufacturers and contained in the technical documents supplied by BGROUP S.P.A. to the Purchaser at the moment of delivery. The Purchaser declares to know and accept the warranties issued by the above mentioned manufacturers.
- d) The Purchaser shall notify BGROUP S.P.A. in writing about all the defects found, and must allow it in any way to acknowledge and remedy them. Such notification shall be sent within and not further than 8 days from discovery, under penalty of expiration.
- e) The Purchaser loses the warranty rights in the following cases: - if the vices and/or defects are due to normal wear of the good; - if the supplied goods are used in an incorrect way or for uses that are above the conditions of the contract and the documents supplied together with the products; - if the defects are caused by an assembly performed by the Purchaser not following the instructions contained in the manual Instructions for use; - if the Purchaser does not perform periodical maintenance exactly following the modes and times established by BGROUP S.P.A.; - if, in presence of possible vices and defects, the Purchaser does not address BGROUP S.P.A. for repair and/or replacement of defective components; - if the Purchaser does not comply with payment deadlines.
- f) BGROUP S.P.A. warranty exclusively consists in free repairing and/or substitution of parts and/or components presenting vices and/or defects, with express exclusion of warranties in articles 1490, 1492, 1497, and 1512 of Italian Civil Code, as well as the one of aliud pro alio and of the obligation to reimburse and/or indemnify any damage, direct or indirect, mediate or immediate, rising from vices and/or defects. We do not recognise any other amount referring to labour, transports, different operations, etc. as it has already been calculated in the commercial granted discount.
- g) The Purchaser shall return the defective goods to BGROUP S.P.A., and the latter may choose whether to repair or replace them. The obligations of BGROUP S.P.A. shall be considered fulfilled when the components duly repaired or replaced are delivered to the Purchaser.
- h) BGROUP S.P.A. has the faculty to send to the purchaser goods replacing the defective ones before the latter have been received; in such case the defective goods shall be sent to BGROUP S.P.A. within 15 days from the date when the replacement goods have been received. Should the Purchaser fail to return the defective goods, which become a property of BGROUP S.P.A., within the above mentioned term - unless expressly authorised in writing by BGROUP S.P.A. - it shall have to pay the goods previously sent to it in replacement.
- i) Costs and risks connected with defective transportation of the product from the Purchaser premises to the premises of BGROUP S.P.A. and the costs of repair performed out of BGROUP S.P.A. plants, will be exclusively on the account of the Purchaser. Similarly, the transportation costs and the risks of the repaired or replaced good from BGROUP S.P.A. premises to the Purchaser premises will be on the account of the Purchaser.

# ***USE AND MAINTENANCE MANUAL***

## ***INDEX***

### **1- GENERAL INFORMATIONS**

- 1.1 - Purpose of this manual
- 1.2 - Machine and manufactured identification
- 1.3 - Machine description
- 1.4 - Technical data
- 1.5 - Safety devices and plates

### **2- Safety information**

### **3- Handling information**

- 3.1- Handling and unloading
- 3.2- Choosing the tractor
- 3.3- Tractor coupling
- 3.4- Uncoupling from the tractor

### **4- User Information**

- 4.1- How to use the equipment
- 4.2- Speed of travel
- 4.3- Adjusting cutting elevator
- 4.4- Aligning the equipment to the ground
- 4.5- Side shift
- 4.6- Travel





### **5- Maintenance information**





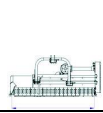

- 5.1- Routine maintenance
- 5.2- Replacing and adjusting the belt
- 5.3- Replacing the tools

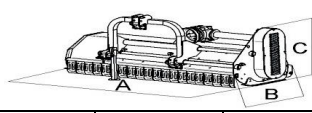
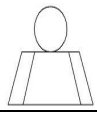

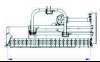

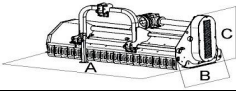

### **6- Troubleshooting**

- 6.1- Foreword
- 6.2- Spares
  - 6.2.1- Interroew wheel RHI
    - 6.2.1.1- Connection

# ENCLOSURE N° 1

MODELLO								
	mm	KW	coltelli	mazze	A	B	C	KG.
PTK 50	480	5-6	14	-	560	700	380	61
PTK 60	580	7-10	16	-	660	700	380	68
PTK 70	680	9-12	18	9	760	700	380	79
PTK 80	780	10-14	22	11	860	700	380	91
PTK 90	880	12-16	24	12	960	700	380	100
PTK 100	980	14-18	24	12	1090	700	380	112
PTK 120	1180	18-20	32	16	1290	700	380	131
GRK 115	1130	20-40	48	16	1250	800	850	225
GRK 130	1280	20-40	54	18	1400	800	850	240
GRK 140	1380	20-40	60	20	1500	800	850	250
GRK 150	1480	20-40	60	20	1600	800	850	260
GRK 160	1580	20-40	66	22	1700	800	850	270
SGK/F 115	1130	20-40	48	16	1250	850	850	270
SGK/F 130	1280	20-40	54	18	1400	850	850	290
SGK/F 140	1380	20-40	60	20	1500	850	850	318
SGK/F 150	1480	20-40	60	20	1600	850	850	325
SGK/F 160	1580	20-40	66	22	1700	850	850	340
SGK/F 175	1730	20-40	72	24	1850	850	850	348
SGK/S 115	1130	30-60	48	16	1250	850	850	320
SGK/S 130	1280	30-60	54	18	1400	850	850	340
SGK/S 140	1380	30-60	60	20	1500	850	850	348
SGK/S 150	1480	30-60	60	20	1600	850	850	356
SGK/S 160	1580	30-60	66	22	1700	850	850	370
SGK/S 175	1730	30-60	72	24	1850	850	850	390
SPK 115	1130	35-65	36	12	1300	1100	1000	390
SPK 130	1290	35-65	36	12	1450	1100	1000	418
SPK 140	1390	35-65	42	14	1550	1100	1000	438
SPK 150	1490	35-65	48	16	1650	1100	1000	458
SPK 160	1590	40-75	48	16	1750	1100	1000	470
SPK 175	1740	40-75	48	16	1900	1100	1000	498
SPK 200	1990	50-80	60	20	2150	1100	1000	550
SPK 230	2290	60-90	66	22	2450	1100	1000	640
SPK 260	2580	60-90	72	24	2750	1100	1000	750
SPK 280	2780	70-110	78	26	2950	1100	1000	805
MTK 150	1480	50-80	32	16	1650	1200	1100	555
MTK 160	1580	50-80	32	16	1750	1200	1100	600
MTK 175	1730	60-90	36	18	1900	1200	1100	625
MTK 200	1980	60-90	40	20	2150	1200	1100	660
MTK 230	2280	60-90	-	22	2450	1200	1100	710
MTK 260	2580	70-120	-	24	2750	1200	1100	820
MTK 280	2780	70-130	-	26	2950	1200	1100	905
VGK 115	1110	40-95	-	12	1350	1200	1100	660
VGK 130	1260	50-100	-	12	1500	1200	1100	730
VGK 150	1460	60-120	-	16	1700	1200	1100	810
VGK 175	1720	70-120	-	18	1950	1200	1100	890
FRK 130	1280	35-65	36	12	1450	1000	1100	415
FRK 150	1480	35-65	48	16	1650	1000	1100	450
FRK 175	1730	40-75	52	18	1900	1000	1100	485
FRK 200	1980	40-75	60	20	2150	1000	1100	520
FRK 230	2280	60-90	66	22	2450	1000	1100	630
FRKR 130	1280	40-75	36	12	1450	1000	1100	475
FRKR 150	1480	40-75	48	16	1650	1000	1100	508
FRKR 175	1730	50-80	52	18	1900	1000	1100	545
FRKR 200	1980	50-80	60	20	2150	1000	1100	575
FRKR 230	2280	60-90	66	22	2450	1000	1100	620
MTKR 150	1480	60-90	32	16	1650	1300	1100	670

MODELLO								
	mm	KW	coltelli	Mazze	A	B	C	KG
MTKR 160	1580	60-90	32	16	1750	1300	1100	715
MTKR 175	1730	60-90	36	18	1900	1300	1100	735
MTKR 200	1980	70-110	40	20	2150	1300	1100	775
MTKR 230	2280	70-120	66	22	2450	1300	1100	860
MTKR 260	2580	80-130	72	24	2750	1300	1100	942
MTKR 280	2780	80-130	78	26	2930	1300	1100	995
BTK 150	1480	70-120	-	12	1650	1250	1200	752
BTK 175	1730	70-120	-	12	1900	1250	1200	817
BTK 200	1980	75-125	-	16	2150	1250	1200	907
BTKR 150	1480	70-120	-	12	1650	1210	1170	862
BTKR 175	1730	70-120	-	12	1900	1210	1170	927
BTKR 200	1980	75-125	-	16	2150	1210	1170	1020
TSK 160	1570	50-80	32	16	1650	1450	1050	520
TSK 200	1970	50-80	40	20	2150	1450	1050	600
TSK 230	2270	50-90	48	24	2450	1450	1050	700
TSK 260	2570	70-110	56	28	2750	1450	1050	780
TSK 280	2770	70-110	64	32	2950	1450	1050	850
TSK 300	2970	70-130	68	34	3150	1450	1050	960
HBK 100	1000	12-25	56	28	650	1100	750	143
HBK 115	1150	12-25	64	32	650	1250	750	159
HBK 130	1300	20-40	72	36	650	1400	750	182
BTLK 160	1600	70-120	32	16	1250	1750	1200	710
BTLK 175	1720	70-120	36	18	1250	1900	1200	726
BTLK 200	1970	70-120	40	20	1250	2150	1200	765
BTLK 230	2270	70-120	66	22	1250	2450	1200	800
BTLK 260	2570	70-120	72	24	1250	2750	1200	880
BTLK 280	2770	75-120	78	26	1250	2950	1200	915
BLK 175	1730	90-120	-	12	1600	2050	1300	1100
BLK 200	1980	90-140	-	16	1600	2300	1300	1270
RHI	Ø 600							
RHI	Ø 800							

MODELLO											
	Mm	KW	coltelli	mazze	A	B	C	D	E	F	KG.
BRKB 130	1280	20-50	54	18	600	700	1300	1850	2160	1850	330
BRKB 150	1480	30-60	60	20	600	900	1500	1850	2360	1850	350
BRKB 175	1730	30-60	72	24	600	1150	1750	1850	2610	1850	385
BRKM 130	1280	20-50	54	18	800	600	1400	1800	2000	1950	330
BRKM 150	1480	30-60	60	20	800	800	1600	1800	2200	1950	386
BRKM 175	1730	40-60	72	24	800	1050	1850	1800	2450	1950	445
BRKM 200	1980	50-70	84	28	800	1300	2100	1800	2700	1950	500
BRK 150	1490	50-80	48	16	765	735	1500	1810	2250	2030	590
BRK 175	1740	60-90	54	18	765	985	1700	1810	2500	2030	625
BRK 200	1990	70-100	60	20	765	1235	2000	1810	2750	2030	700
BRKE 150	1490	50-60	48	16	790	710	1500	1810	2500	2030	590
BRKE 175	1740	60-70	54	18	790	960	1700	1810	2750	2030	625
BRKE 200	1990	70-80	60	20	790	1210	2000	1810	3000	2030	700

# 1

## GENERAL INFORMATION

### 1.2 MACHINE AND MANUFACTURER IDENTIFICATION

Caption:

- A** - Manufacturer ID
- B** - Machine model
- C** - Serial number
- D** - Date of manufacture
- E** - Weight in kg
- F** - CE compliance marking

	
IMA.IT SRL C.F. / P.IVA 02862780737 S.S. 7 Ter Z.I. MANDURIA (TA) ITALY	
Designazione Designation	<input type="text"/>
Tipo Type	<input type="text"/>
Anno Year	<input type="text"/>
Numero di identificazione Serial identification number	<input type="text"/>
Pressione massima Max pressure	<input type="text"/> bar
Massa limite complessiva Max total load weight	<input type="text"/> Kg
Massa limite a vuoto Max loadless weight	<input type="text"/> Kg

### 1.3 MACHINE DESCRIPTION

This piece of equipment was designed and built for use in farming, and especially for fine chopping of grass, runners of orchards, vineyards, green areas, etc.

Any other use, unless authorised in writing by the manufacturer, will exempt the manufacturer from any liability for damage to people or to the machine.

To use this device, the driver must apply it to the hoist of a farming tractor of suitable capacity and stability (see technical data). It comes in several models for different requirements, especially different working widths.

Caption

- A** - Main structure
- B** - Three points traversing linkage (with mechanical and hydraulic actuation)
- C** - Drive unit with inside freewheel
- D** - Knife-holder rotor
- E** - Support roller
- F** - Safety strap

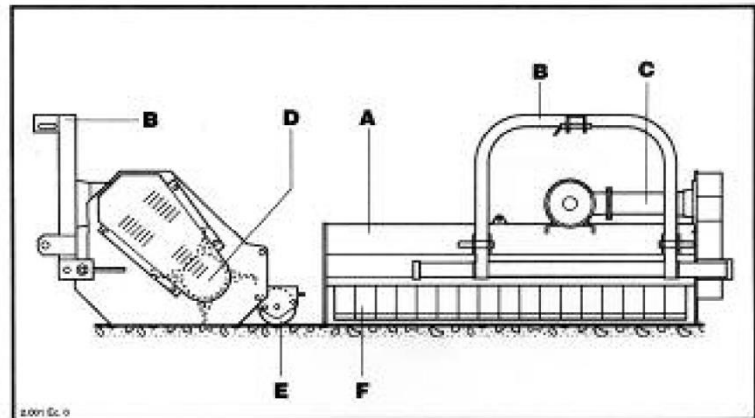



IMA.IT SRL C.F. / P.IVA 02862780737  
S.S. 7 Ter Z.I. MANDURIA (TA) ITALY

Designazione <i>Designation</i>	<input type="text"/>		
Tipo <i>Type</i>	<input type="text"/>	Anno <i>Year</i>	<input type="text"/>
Numero di identificazione <i>Serial identification number</i>	<input type="text"/>	Pressione massima <i>Max pressure</i>	<input type="text"/> bar
Massa limite complessiva <i>Max total load weight</i>	<input type="text"/> Kg	Massa limite a vuoto <i>Max loadless weight</i>	<input type="text"/> Kg

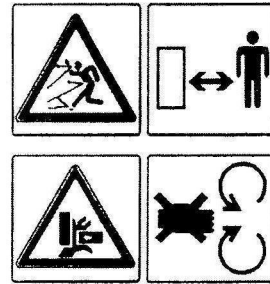

# 1

## GENERAL INFORMATION

---

**C** - General danger: turn the engine off and take the key out before performing any operation on the machine.



**D** - You must wear gloves to couple to the tractor.



**E** - Rotation direction and maximum permitted speed.



**F** - Plate with equipment loading and unloading instructions.

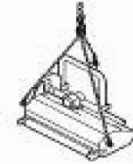

**G** - Strap device to prevent stones from being shot out.

**H** – Cardan shaft guard.

**L** - Device for cardan shaft during uncoupling from the tractor.

**M** - Driving belt fixed guard.



**2.1 OBLIGATIONS, PROHIBITIONS AND DANGER**

- Read the information carefully and comply strictly with it, especially with information concerning safety: safety is in your hands. However, nothing can prevent accidents more than constant attention - when the accident has already taken place, it will be too late to remember what should have been done.
- Comply strictly with all the instructions concerning danger, prohibitions and obligations contained in this manual or written directly on the machine.
- Apply the equipment only on tractors provided with three points linkage device, of sufficient strength and steadiness.
- Make sure all the guards of the cardan shaft are in good condition, properly assembled and suitably connected so they do not turn.
- The user must comply with general rules on safety in the workplace and accident prevention and with all the traffic bylaws during road transportation.
- You must make sure that there are no people and/or animals within the working range of the equipment. If necessary, send them away before starting the equipment up.
- You must take the utmost care when working on rough ground; under such conditions, the guards become temporarily inefficient, and there is danger of fragments being shot out at a greater distance than is normally to be expected.
- When loading and unloading the equipment, use suitable lifting media and comply with the manufacturer's instructions; it may be dangerous to lift the machine in an unbalanced manner.
- It is forbidden to use the equipment when the guards have been removed or are incomplete.
- It is forbidden to wear loose clothing and/or objects which might easily get caught in any moving part.
- It is forbidden to carry people, animals or things on the equipment.
- It is forbidden to use the equipment in unsuitable environment or weather, with low visibility or during the night.
- Any kind of intervention on the equipment must be performed only when the machine parts are not moving, the tractor engine has been turned off and the tractor is parked with the ignition key taken out.
- When travelling, especially along public roads, drive at a moderate speed. Remember the equipment exerts a strong centrifugal force which may affect the driving sensitivity of the tractor.

# 2

## ***SAFETY INFORMATION***

---

- Make sure the cardan shaft connecting to the tractor is marked according to European Community laws.

# 3

## HANDLING INFORMATION

---

### 3.1 LOADING AND UNLOADING

Perform these operations with the cardan shaft disconnected, as shown on the figure and also directly on the equipment.



**Only use lifting accessories and media suited to the weight of the equipment.**

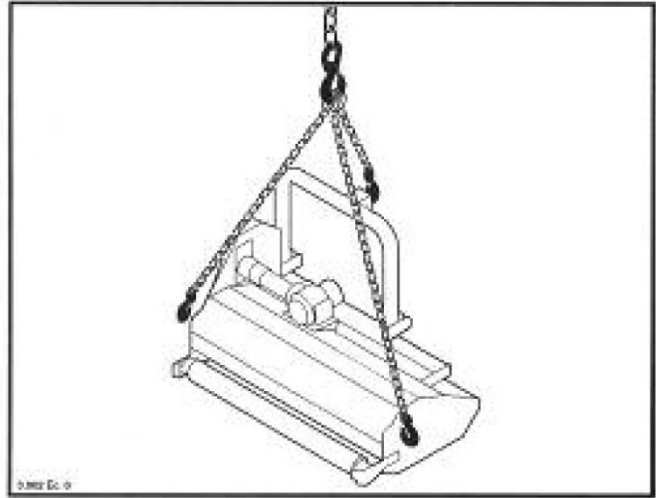

### 3.2 CHOOSING THE TRACTOR

When choosing which tractor to apply the equipment to, besides considering features of power and steadiness, you should prefer those with sound-proof and pressurised cabs. Otherwise, the operator must wear ear muffs and - when working in situations with a great deal of dust - a dust mask too.

### 3.3 TRACTOR COUPLING

Approach slowly with the tractor. Adjust the arms of the hoist properly so they coincide with the coupling points of the equipment.



**This operation must never be performed with help from other people.**

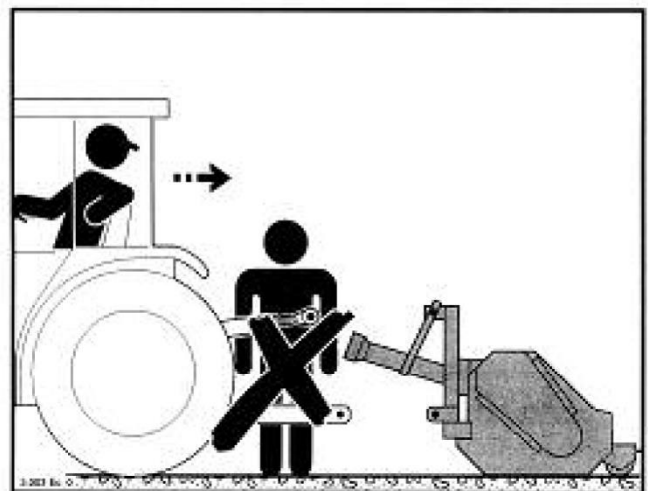

# 3

## HANDLING INFORMATION



**Danger - Caution:** when coupling the device to the tractor, and before fitting the pins, make sure the machine parts are not moving, the tractor engine has been turned off and the tractor is parked with the ignition key taken out.

- Fit the coupling pins and the fastening pegs; first on both bottom couplings and then on the top one.
- Fit the cardan shaft to the power take-off of the tractor.
- Connect the chains of the fixed part guard of the tractor and of the equipment.

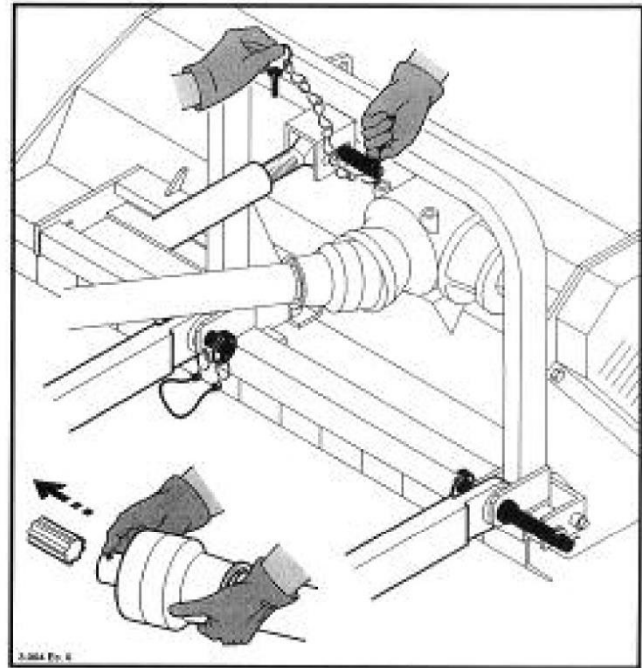

**Danger - Caution:** to ensure safety, make sure the cardan shaft and its guards are perfectly efficient.

### 3.4 UNCOUPLING FROM THE TRACTOR

When uncoupling the equipment from the tractor, we suggest you proceed as follows.

- Choose the best and most solid flat surface: remember this will help when coupling to the tractor again.
- If you expect to park for a long time, make sure the equipment is not easily reached by children, and is suitably cleaned and lubricated so it is ready to be used again.
- Lower the equipment, resting it on the ground.

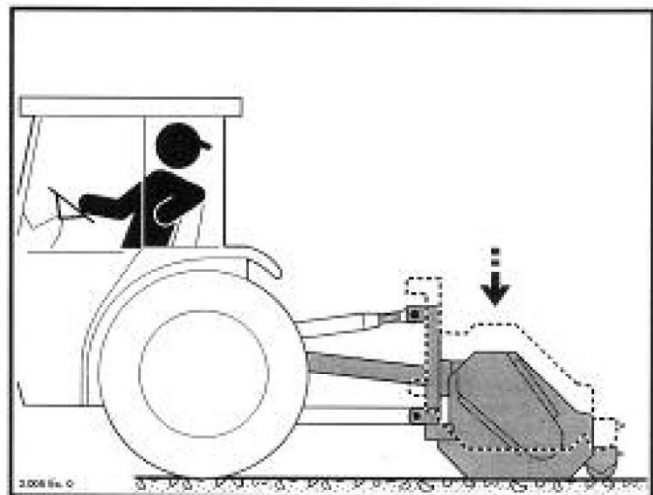

# 3

## HANDLING INFORMATION



**Danger - Caution:** before uncoupling, make sure the machine parts are not moving, the tractor engine has been turned off and the tractor is parked with the ignition key taken out.

- Disconnect the cardan shaft from the tractor power take-off and fit it into its support.
- Take the pins of the three linkage points out. Remember to keep the pins and their pegs, putting them into the slots on the equipment.

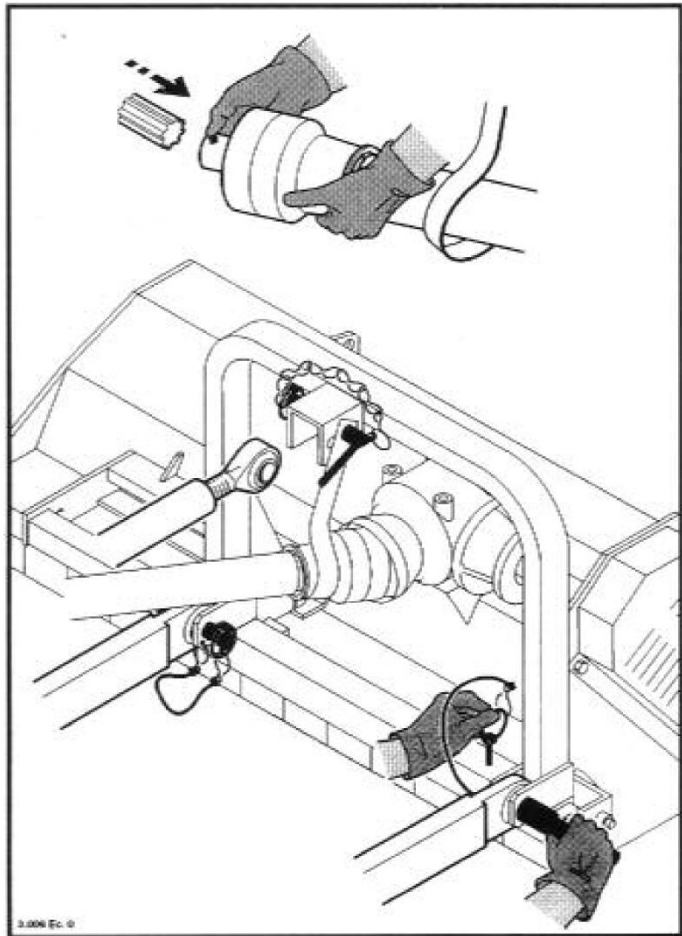

# 4

## USER INFORMATION

---

### 4.1 HOW TO USE THE EQUIPMENT

Use of the shredder range choppers is not difficult. To optimise working quality, all you need are some basic operations depending on the kind of work you intend to do.

Pay special attention to the tools (knives and flails). When using the equipment on difficult ground, when working at a very low cutting elevation, impact against obstacles may wear the tools quickly; to achieve best results, you must preserve them in good condition.



**Forbidden to carry people, animals or things on the equipment**

The user must also bear in mind other factors from time to time; following is a list of suggestions on how to get the best out of the job.

### 4.2 SPEED OF TRAVEL

The shredder choppers are designed for heavy duty. Depending on the job you want to do, you must find the right compromise between speed of travel and the quality of the job you want to do.

To achieve this aim, you must take into consideration the number of minimum and maximum revs (300 to 540 rpm) and the maximum absorbed power.

Start moving forward only when the rotation speed has reached its right speed.

### 4.3 ADJUSTING CUTTING ELEVATION

Work on the arm of the third point or else adjust the height of the supporting roller using the screws **A** which may be fastened in any of the three positions.

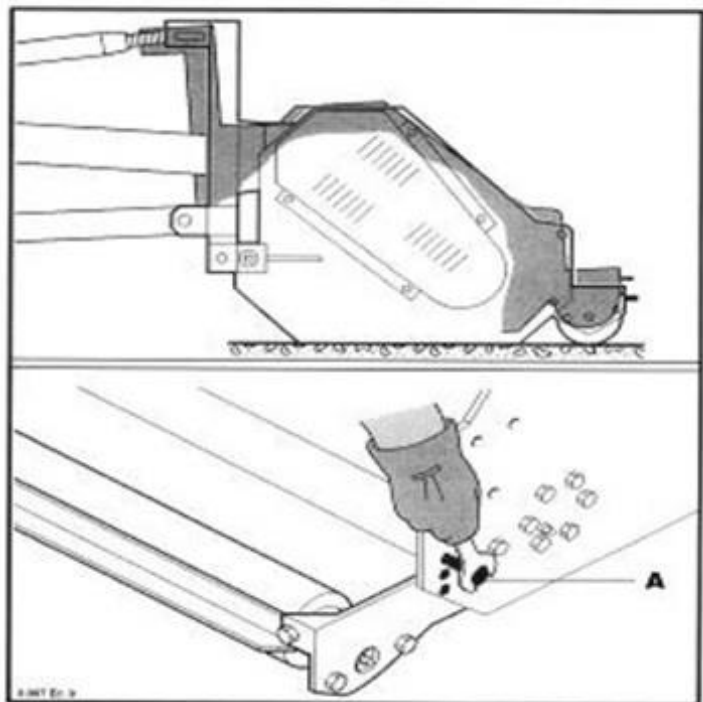

### 4.4 ALIGNING THE EQUIPMENT TO THE GROUND

With the tractor in its working position, the equipment must rest uniformly on the whole width of the ground being worked on.

This can be done by working on the adjustable arm of the tractor hoist.



You must lift the equipment while moving in reverse and before performing "return curves" at the end of the row, in order to avoid stressing the equipment.

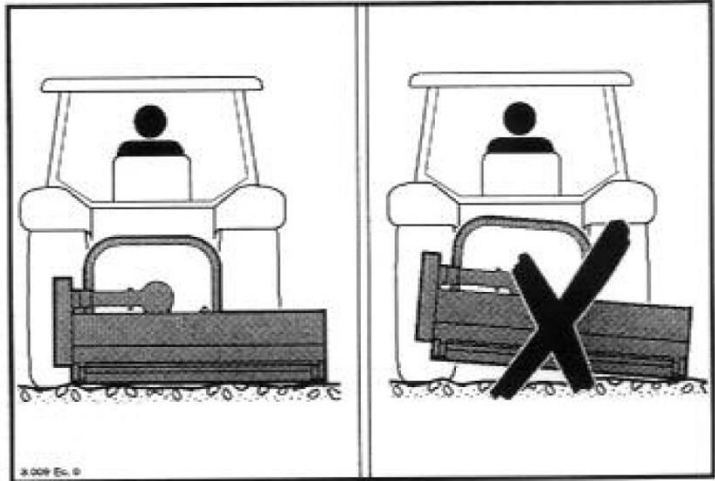

### 4.5 SIDE SHIFT

This device allows you to place the equipment in different positions, moving it laterally compared to the gauge of the tractor. This shift may be mechanical **A** type or hydraulic **B** type.

When using the hydraulic type, the tractor must be provided with a double-acting control valve.

The side shift must be done only when the equipment is lifted above the ground.

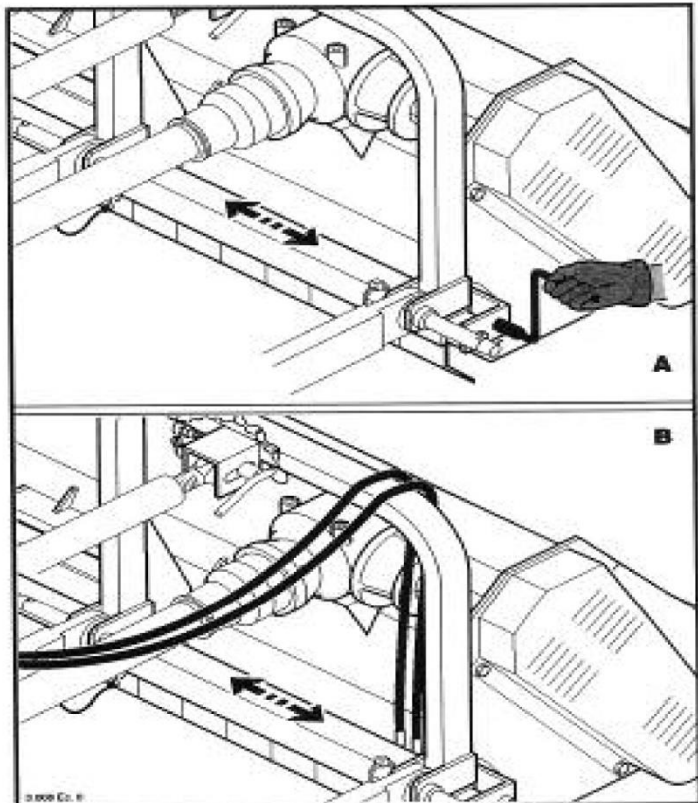

#### 4.6 TRAVEL

Should one have to move the equipment on public roads, the driver of the tractor must of course have all the requirements needed under law; he must also take the following precautions:

- place the equipment at the centre line of the gauge of the tractor;
- lock the side shifts of the hoist using both tie-rods, to prevent the equipment from suddenly shifting;
- use the necessary signs to point out the shape of the equipment;
- make sure the power take-off is disconnected and the equipment has no residue material on it.

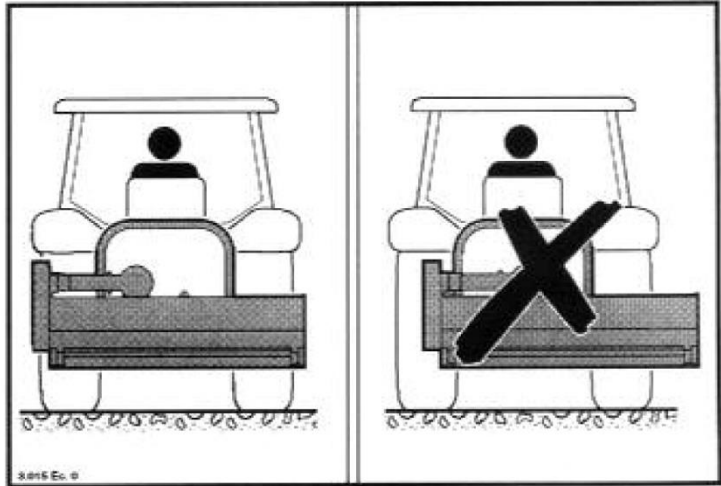

**Danger - Caution: during travel, drive the tractor slowly in order to avoid any dangerous skidding.**



# 5

## MAINTENANCE INFORMATION

### 5.1 ROUTINE MAINTENANCE

We suggest routine maintenance operations in order to ensure good performance through time, while considering the various environmental and weather conditions which the equipment works in.

☐ **Every 8 hours:**

- grease the points shown on the picture;
- check the wear and the attachment of the tools (knives or flails).

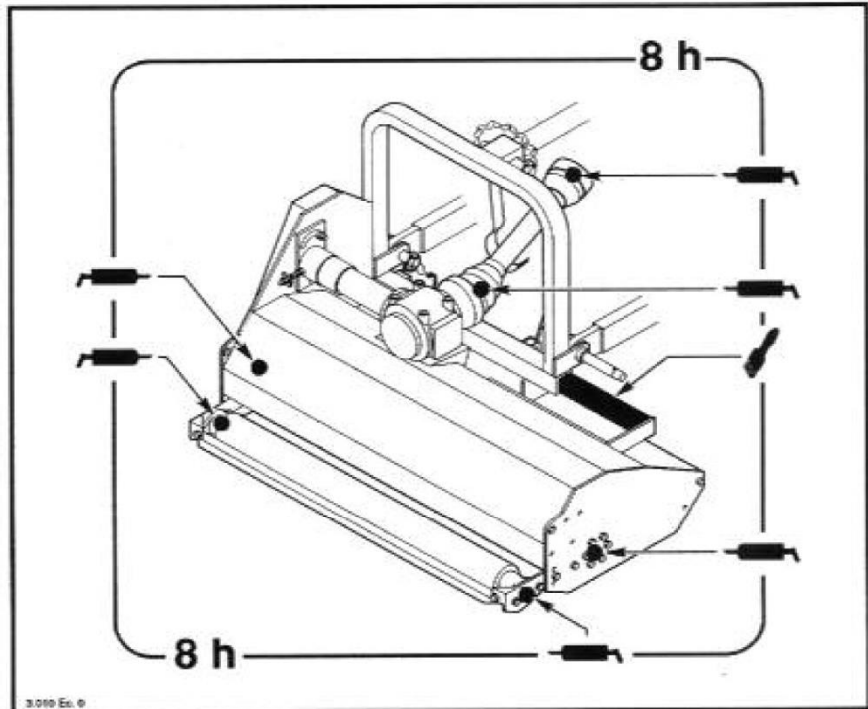

☐ **At regular time intervals**

- Clean, and if necessary wash, the inside and outside parts of equipment, removing all the residue which has accumulated.

### 5.2 REPLACING AND ADJUSTING THE BELT

Check the belt tension regularly, as shown on the figure.

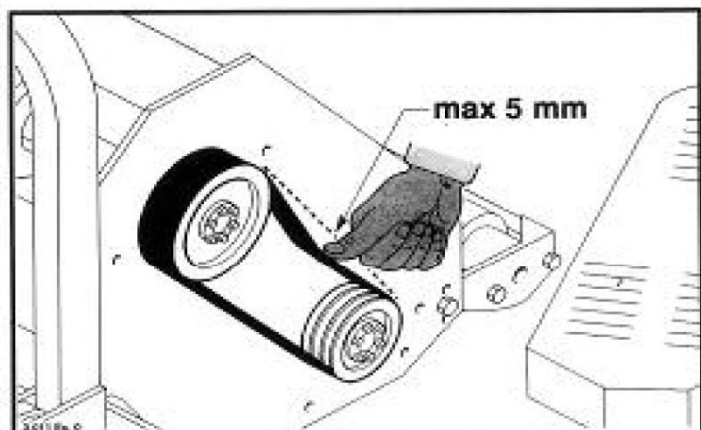

# 5

## MAINTENANCE INFORMATION

Should you have to replace and/or adjust the belts, proceed as follows:

- loosen the screws **A**;
- loosen the screws **B** and **C**;
- take the worn belts out and replace them;
- adjust tension using the adjustment screw **D**;
- after having completed the adjustment, screw all the screws back on carefully.



You must only use Agricom original spare parts.

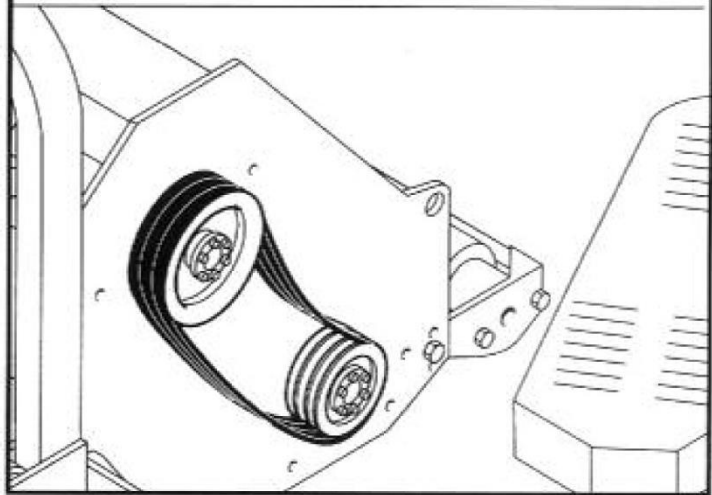
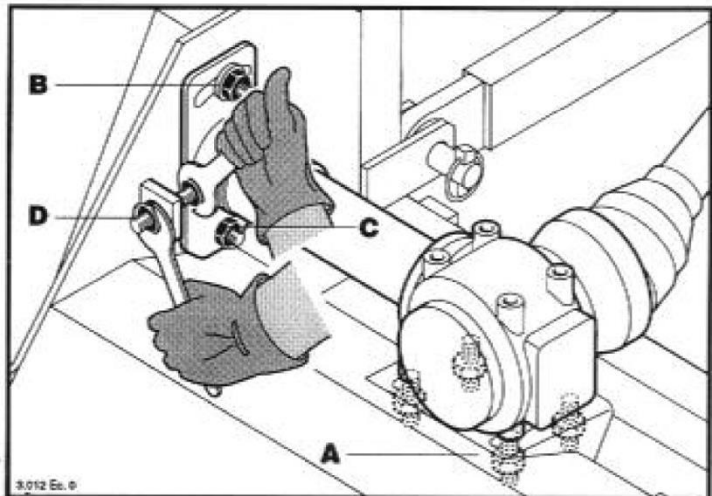

### 5.3 REPLACING THE TOOLS

After having turned the machine over as shown on the picture, replace those elements which show breakages or heavy wear.



**Information:** so as not to unbalance the tool carrying arbor, hence creating damaging vibrations, we suggest you replace the diametrically opposite tools.

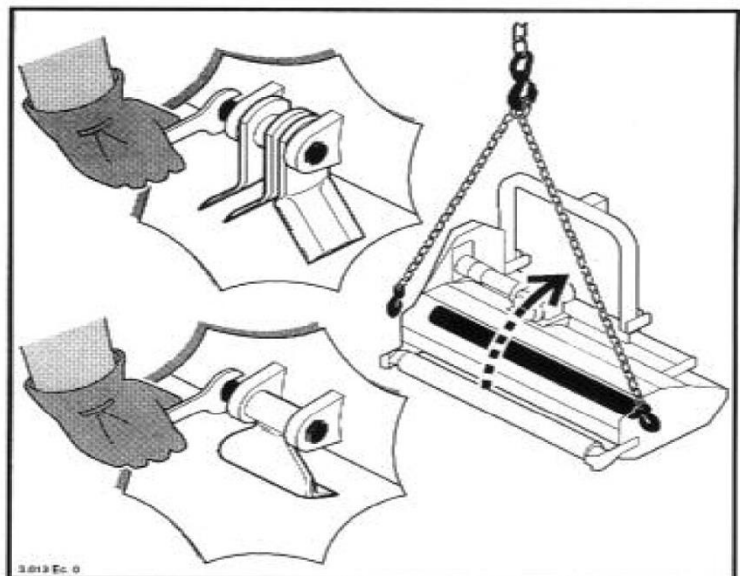

# 5

## **MAINTENANCE INFORMATION**

---

Should you have to replace the tools completely, it is good practice to weigh them one by one so you can assemble them opposite each other, avoiding vibrations. After having replaced the tools, lift the equipment and slowly increase the rotation speed until you reach maximum speed without there being any obvious vibration.

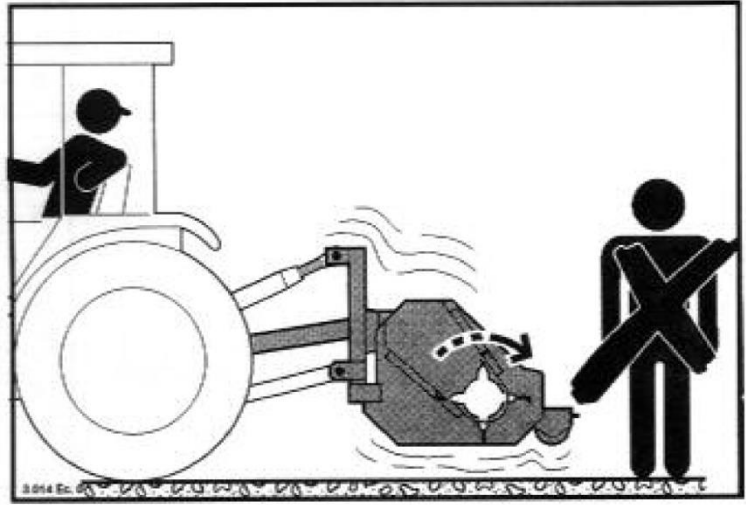

# 6

## TROUBLESHOOTING

### 6.1 FOREWORD

During the life of the equipment, you may come across some of the faults listed below. Once you have identified the reason, you can find the right solution; when replacing special items, we suggest you use original spare parts.

Should you meet with difficulty in solving the problems you come across, refer directly to the manufacturer and/or to specialised and authorised repair shops.



**Danger - Caution: all troubleshooting must be done only when the machine parts are not moving, the tractor engine has been turned off and the tractor is parked with the ignition key taken out.**

TROUBLE	REASON	REMEDY
Support roller blocked	The chopped material prevents the roller from turning.  There is earth in the bearing inside the roller.  The bearings have not been greased sufficiently.	Dismantle the earth scraper and clean the roller. Replace the bearings. To prevent the problem from happening again, make the curve at the end of the row with the machine hoisted above ground. Grease the greasing points.
The machine shakes.	Breakage or loss of a flail or a knife. Loss of a balancing weight. Accidental bending of the rotor in the central part.	Replace the flail or the knife. Weld a new, equivalent weight onto the rotor <sup>(1)</sup> . Re-balance the rotor <sup>(1)</sup> .
Rotor jammed.	Rotor jammed by pieces of wood, steel wire or other objects.	Free the rotor from foreign matter, making it turn in the opposite direction.
Excessive power absorption.	The chopper is working on damp ground. The diameter and/or quantity of the material being chopped are excessive. The flails are working too close to the ground.	Slow down the working speed. Move more slowly, letting the crushed material come out. Adjust the height of the chopper suitably.
Insufficient chopping of the material.	The flail or knife carrying arbor does not reach the right number of revs. The power take-off is too slow. The chopper elevation has not been adjusted properly. The flails/knives are too worn. The speed of travel is too high.	Tension the belts properly. On the dashboard, make sure the number of engine revs and the number of take-off revs coincide exactly. Adjust the chopper according to instructions. Replace the flails or knives. Adjust the speed depending on the cutting power.

<sup>1</sup> This operation must be carried out by skilled personnel.

## 6.2 SPARES

When ordering spares, please always supply the following informations:

- 1) machine type
- 2) serial number
- 3) table number
- 4) item reference number
- 5) item code
- 6) required quantity
- 7) way of shipment

### 6.2.1 INTERROW WHEEL RHI

On demand the machine can be equipped with Interrow wheel accessory .  
The interrow wheel can be of three types

**RHI** : RHI: Inter-row wheel with mechanical spring return with quick coupling to tractor, slant for ditches, mechanical adjustment.

In the three models RHI, the diameter of the wheel can be 600 mm and 800 mm.

The wheel is mounted on the mulcher sideways in order to cut in the spaces where it's not possible to act with the main machine .

#### 6.2.1.1

Connection

- " For RHI model connect hydraulic hoses supplied as standard to the tractor PTO with bolts supplied as standard ; fix the wheel at the shredder.(see figure.).

Operation:

" On RHI use PTO lever tractor that makes hydraulic wheel movement.



Warning:

1. 1. projection of objects Hazard: keep at a safe distance from the machine.
2. danger of shearing toes: keep at a safe distance from the machine.

NOTE:

:

For the interrow wheels purchased separately from shredder and utilized on other shredders , the manufacturer assumes no liability for malfunction due to:

-incorrect installation

-different use

-non-compliance with the safety requirements..

in addition the interrow wheel sold separately , not being an autonomous machine, should be certified in accordance with the rules on the part of those who install, sell or enter the inter-row wheel on the market..

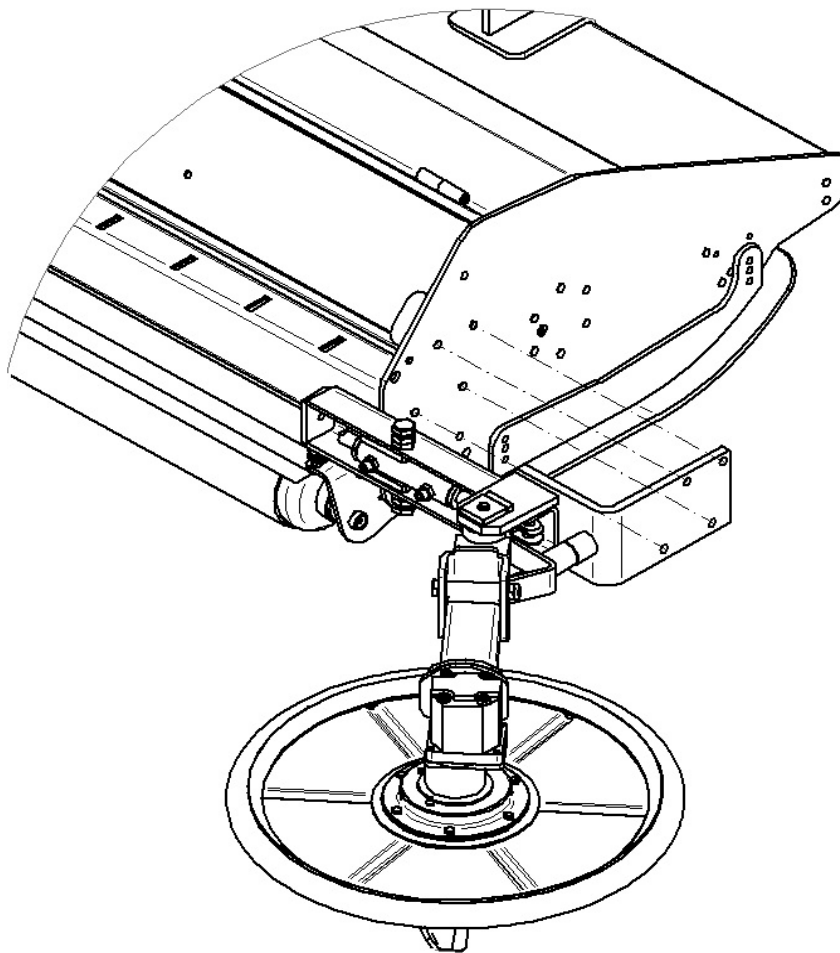

# **BARGAM<sup>®</sup>**

## **Agriculture**



**BGROUP S.p.A. È Sede legale e operativa/Registered Office and Production Plant:** Via della Cooperazione, n. 20 40026 IMOLA (BO) - ITALY  
Tel. +39 0542 648511 . Fax +39 0542 640539 . website: [www.bgroup.info](http://www.bgroup.info) . email: [info@bgroup.info](mailto:info@bgroup.info) . pec: [pec.bgroup@legalmail.it](mailto:pec.bgroup@legalmail.it)  
Reg. Impr./ Cod. Fisc./ P.IVA 01463360436 (VAT IT 01463360436) . cap. soc. " 3.376.700 . R.E.A. 430696 . Cod. Mecc. BO 052044  
**Stabilimento Produttivo Jesi/Production Plant Jesi:** Via G. Pastore, n. 5/A ZIPA 60035 JESI (AN) - ITALY - Tel. +39 0731 208384/56173 . Fax +39 0731 211087