

# BARGAM<sup>®</sup>

Agriculture



Fan Sprayers



## Un mondo di soluzioni

A world of solutions - Un monde de solutions - Viele Lösungen - Un mónton de soluciones

[www.bargam.com](http://www.bargam.com)

IT GB FR DE ES





**BARCO**



**Un mondo d**

A world of solutions - Un monde de solutions - V

[www.barco](http://www.barco.com)





**GAM**<sup>®</sup>  
Fan Sprayers

di soluzioni

s - Viele Lösungen - Un montón de soluciones

[gam.com](http://gam.com)



- Ⓜ **IT** Nebulizzatori e atomizzatori portati da 200 a 1000 litri
- Ⓜ **GB** Mist blower and mounted orchard sprayers from 200 lt to 1000 lt
- Ⓜ **FR** Nebuliseurs et atomiseurs portés de 200 L à 1000 L
- Ⓜ **DE** Anbauen Zerstäuber und Sprühgerät von 200 lt bis 1000 lt
- Ⓜ **ES** Nebulizadores y atomizadores suspendidos de 200 lt a 1000 lt



## Turbo AP45 Flex



- Ⓜ **IT** KIT ILLUMINAZIONE
- Ⓜ **GB** LIGHT SET
- Ⓜ **FR** KIT ECLAIRAGE
- Ⓜ **DE** BELEUCHTUNG KIT
- Ⓜ **ES** SISTEMA ILUMINACION



- Ⓜ **IT** LAVABARATTOLI
- Ⓜ **GB** CAN CLEANER
- Ⓜ **FR** RINCAGE DES BIDONS
- Ⓜ **DE** KANISTERREINIGUNG
- Ⓜ **ES** LAVADO CONTENEDORES



- Ⓜ **IT** MISCELATORE POLVERI
- Ⓜ **GB** PRE-MIXER
- Ⓜ **FR** PREMELANGEUR
- Ⓜ **DE** EINSPÜLKERZE
- Ⓜ **ES** MEZCLADOR DE POLVOS



- Ⓜ **IT** AGITATORE IDRAULICO STANDARD
- Ⓜ **GB** STANDARD HYDRAULIC AGITATOR
- Ⓜ **FR** AGITATEUR HYDRAULIQUE STANDARD
- Ⓜ **DE** HYDRAULISCHES STANDARD-RÜHRWERK
- Ⓜ **ES** AGITADOR HIDRÁULICO STANDARD



- Ⓜ **IT** AGITATORE IDRAULICO
- Ⓜ **GB** HYDRAULIC AGITATOR
- Ⓜ **FR** AGITATEUR HYDRAULIQUE
- Ⓜ **DE** HYDRAULISCHES RÜHRWERK
- Ⓜ **ES** AGITADOR HIDRÁULICO

# BARCO

## Un mondo di

A world of solutions • Un monde de solutions • V

[www.barc.com](http://www.barc.com)



### Turbo AP45

#### IT Dotazioni e accessori

#### GB Equipment and accessories

#### FR Equipements et acc

6



IT KIT FILTRO IN ASPIRAZIONE  
GB KIT SUCTION FILTER  
FR KIT FILTRE D'ASPIRATION  
DE KIT SAUGFILTER  
ES KIT FILTRO EN ASPIRACION

7



IT FILTRO  
GB FILTER  
FR FILTRE  
DE FILTER  
ES FILTRO

8



IT FILTRO AUTOPULENTE  
GB SELF-CLEANING FILTER  
FR FILTRE AUTONETTOYANT  
DE SELBSTREINIGUNG FILTER  
ES FILTRO AUTOLIMPIANTE

9



IT POMPA IN ALLUMINIO  
GB ALUMINIUM PUMP  
FR POMPE EN ALUMINIUM  
DE PUMPE AUS ALUMINIUM  
ES BOMBA EN ALUMINIO

9



IT POMPA IN BRONZO  
GB BRONZE PUMP  
FR POMPE EN BRONZE  
DE PUMPE AUS BRONZE  
ES BOMBA EN LATÓN



di soluzioni

s - Viele Lösungen - Un montón de soluciones

gam.com



**AP Pneus**

accessoires

DE Ausrüstung und Zubehör

ES Equipos y accesorios

9



- IT POMPA A PISTONI
- GB PISTON PUMP
- FR POMPE A PISTON
- DE KOLBENPUMPE
- ES BOMBAS DE EMBOLOS

10



- IT COMANDO ELETTRICO ON-OFF
- GB ELECTRICAL CONTROL UNIT ON-OFF
- FR DISTRIBUTEUR ELECTRIQUE ON-OFF
- DE ELEKTRISCHE ARMATUR ON-OFF
- ES MANDO ELÉCTRICO ON-OFF

10



- IT KIT COMANDO ELETTRICO
- GB ELECTRICAL CONTROL KIT
- FR DISTRIBUTEUR ELECTRIQUE
- DE ELEKTRISCHE ARMATUR
- ES MANDO ELÉCTRICO

11



- IT GETTO DOPPIO
- GB DOUBLE NOZZLE
- FR BIJETS
- DE ZWEIFACHDÜSEN
- ES DOBLE BOQUILLA

12



- IT GETTO DOPPIO CANNONCINO
- GB DOUBLE AIR-INJECTOR NOZZLE
- FR DOUBLE BUSE A CANON
- DE ZWEIACHE WEITWÜRFDÜSE
- ES BOQUILLAS DE CANON

- IT** I dati e le descrizioni del presente opuscolo hanno soltanto valore indicativo.
- GB** The specifications and descriptions in the brochure are purely indicative.
- FR** Les données et les caractéristiques de cette brochure ne sont fournies qu'à titre indicatif.
- DE** Broschüre Aufgeführten Daten und Merkmale gel ten als Richtlinie.
- ES** Los datos y las descripciones del presente folleto tienen solamente valor indicativo y podran ser cambiados sin previo aviso.



## AP 70 Control

13



ATR 80° ATR 60° ATI 60°  
TVI 80° CVI 80° AVI 80°

- IT** UGELLI ALBUZ  
**GB** ALBUZ NOZZLES  
**FR** BUSES ALBUZ  
**DE** DÜSEN ALBUZ  
**ES** BOQUILLAS ALBUZ

14



- IT** TAPPO GRV CONTROL  
**GB** GRVCONTROL PLUG  
**FR** BOUCHON GRV CONTROL  
**DE** STOPFEN GRVCONTROL  
**ES** TAPON GRV CONTROL

15



- IT** VENTILATORE PNEUS  
**GB** PNEUS FAN  
**FR** VENTILATEUR PNEUS  
**DE** PNEUS LUEFTER  
**ES** VENTILADOR PNEUS

16



- IT** MULTIPLICATORE 2V  
**GB** 2S GEARBOX  
**FR** 2V MULTIPLICATEUR  
**DE** 2G GETRIEBE  
**ES** 2V MULTIPLICADOR

17



- IT** ELICA CONTROL  
**GB** CONTROL FAN  
**FR** VENTILATEUR CONTROL  
**DE** CONTROL LUEFTER  
**ES** VENTILADOR CONTROL

**BARGAM**  
Fan Sprayers



## POLI 70 New Control

**IT** VANTAGGI:

CONVOGLIATORE IN POLIETILENE CON:  
LA PARTICOLARE GEOMETRIA IMPEDISCE  
L'ASPIRAZIONE DI FOGLIE, POLVERI E  
TERRA LE QUALI POTREBBERO ROVINARE  
IL PRODOTTO.

BOCCHETTE USCITA 'ARIA AD APERTURA  
E CHIUSURA INDIPENDENTI MEDIANTE  
TAPPO A BAIONETTA CHE PERMETTONO  
UNA MAGGIORE CANALIZZAZIONE  
DELL'ARIA.

ELICA CON FRIZIONE A 10 PALE E  
MULTIPLICATORE IN GHISA

GETTI DOPPI ANTIGOCCEA CHE RIDUCONO  
LO SPRECO DI PRODOTTO.

**GB** ADVANTAGES:

CONVEYOR WITH POLYETHYLENE:  
THE SPECIAL GEOMETRY PREVENTS  
INDUCTION OF LEAVES, DUST AND LAND  
WHICH MAY RUIN THE PRODUCT.

JETS-OUT 'INDEPENDENT AIR OPENING  
AND CLOSING BY PLUG BAYONET THAT  
ALLOW MORE AIR DUCT.

PROPELLER WITH A 10 WHEEL AND  
CLUTCH IRON MULTIPLIER

DOUBLE DRIP JETS REDUCING WASTE  
PRODUCT.

**FR** AVANTAGES:

CONVOYEUR EN POLYÉTHYLÈNE:  
LA GÉOMÉTRIE PARTICULIÈRE EMPÊCHE  
L'APPORT DES FEUILLES, POUSSIÈRE ET LA  
TERRE QUI POURRAIT RUINER LE PRODUIT.

SORTIE D'AIR AVEC BOUCHONS  
D'OUVERTURE ET DE FERMETURE  
PAR BAIÛNETTE INDÉPENDANTES  
QUI PERMETTENT UNE PLUS GRANDE  
CANALISATION DE L'AIR .

HÉLICE AVEC EMBRAYAGE À 10 PALES  
EN GHISE

DOUBLES BUSES ANTIGOUTTE QUI  
PERMETTENT DE RÉDUIRE LE GASPILLAGE  
DE PRODUIT.

**IT** Il nuovo atomizzatore "Poli 70 New Control" con gruppo ventola Bargam "New Control" Brevettato è stato ideato e realizzato per soddisfare al meglio le attuali esigenze del mercato in materia di salvaguardia dell'ambiente e tutela dell'operatore. Il nuovo design della cisterna e del telaio in tubolare garantisce elevati quantitativi di prodotto in ingombri ridotti della macchina. La particolare geometria del gruppo ventola "New Control" e la disposizione dei bocchettoni indipendenti consentono l'uso nelle più svariate colture (Vigneto a tendone, A spalliera, Frutteto, Agrumeto, Oliveto) garantendo il massimo delle prestazioni quali:

- Proteggere l'ambiente con un'efficiente distribuzione.
- Impedire l'ingresso nel convogliatore di foglie, polveri e terra evitando così di rovinare le colture.
- Aumentare la quantità e la velocità dell'aria con l'utilizzo di bocchette di uscita indipendenti.
- Ottimizzare la distribuzione di aria nonché di prodotto utilizzato con consumi ridotti a partire da 250/300 lt/ha.
- Direzionare il flusso dell'aria e di conseguenza del prodotto direttamente sulla pianta da trattare.
- Ottenere la massima copertura, una maggiore penetrazione ed una perfetta distribuzione.

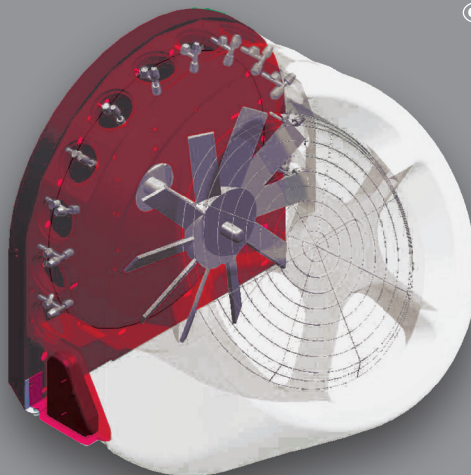

**GB** The new sprayer "Poli 70 New Control" with fun group Bargam "New Control" patented has been designed and developed to best meet current market needs in the field of environmental protection and protection of the operator. The new design of the tank and the tubular frame provides high quantities of product in reduced dimensions of the machine. The particular geometry of the fan assembly "New Control" and the provision of independent outputs allow use in various crops (vineyard canopy, espalier, orchard, citrus and olive plantations) ensuring maximum performance such as:

- Protect the environment with an efficient distribution.
- Prevent entry into the conveyor leaves, dust and earth avoiding damages on the crops.
- Increase the amount and speed of the air vents with the use of independent output.
- Optimize air distribution and consumption of product may be reduced from 250/300 l / ha.
- Direct the air flow and consequently the product directly on the plant to be treated.
- Get maximum coverage, a greater penetration and a perfect distribution.

**FR** Le nouveau atomiseur "Poli 70 New Control" avec le ventilateur breveté Bargam "New Control" a été conçu et développé pour répondre mieux aux besoins actuels du marché en matière de sauvegarde de l'environnement et de la protection de l'opérateur, la nouvelle conception de la cuve et le châssis tubulaire fournit de grandes quantités de produit dans des dimensions réduites de la machine. La géométrie particulière du groupe ventilateur new control et la dispositions de bouchons indépendants fournissent l'utilisation dans les cultures les plus variées (vigne Canopée , en espalier, arbres fruitiers, citronniers, oliviers) en assurant des performances maximales telles que:

- Protéger l'environnement avec une distribution efficace.
- Éviter l'entrée dans le convoyeur de feuilles, poussière et la terre en évitant ainsi d'endommager les cultures.
- Augmenter la quantité et la vitesse d'utilisation de l'air d'évents de sortie indépendants.
- Optimiser la distribution d'air et d'utilisation des produits à faible consommation à partir de 250/300lt/ha.
- Diriger le flux de l'air et par conséquent le produit directement sur la plante à traiter.
- Obtenir une couverture maximale, la pénétration et une parfaite distribution.

**DE** Der neue Sprühgerät "Poli 70 New Control" mit patentierte Ventilatoraggregate Bargam "New Control" um den Bedürfnissen aktuellen marktsituation und zum Schutz der Umwelt und des bedieners realisiert ist. Der neue Design der neuen Tank und der Rahmen in tubular garantieren eine hohe Menge an Produkt in reduziert abmessungen der Maschine. Die besondere Geometrie der Ventilatoraggregate "New Control" und die Anordnung der Unabhängigen gewerkschaften garantieren die Einsatz in verschiedenen kulturen (tuch Weinbau, spalieren Weinbau, Agrumen Pflanzung, Obstgarten, Olivenhain). Sie garantieren:

- Schützen die umwelt mit einem wirkungsgrad distribution
- Verhindern die einzig im forderwerk von blatter, stauf, erde und dunnen stein um der scheiden der kulturen vermeiden .
- Vermehren die qualitat und der geschwindigkeit der luft mit dem verwendung der unhab hängige ausgänge
- Optimierung der verteilung von luft und verwendet produkt mit reduziert verbrauch von 250/300 lt/ha.
- Richtun der luftstrom und produkt direkt auf die pflanze zu behandelnden.
- Anreise die maximale bedeckung, eine stärkere durchdringung und eine perfekte verteilung.

**ES** El nuevo atomizador "Poli 70 New Control" con una unidad de ventilador patentado por Bargam fue diseñado y desarrollado para satisfacer mejor las necesidades actuales del mercado en el campo de la protección del medio ambiente y la protección del operador. El nuevo diseño del tanque y la estructura tubular proporciona grandes cantidades de producto en reducidas dimensiones de la máquina. La geometría especial del conjunto de ventilador y la colocación de los grifos independientes y el frontal de la unidad controlada (lo que evita la entrada de hojas y de las partículas dentro de la turbina) permiten el uso en diversos cultivos (viña emparrado, Invernadero, huerto, cítricos y olivares) asegurando el máximo rendimiento,

- Proteger el medio ambiente con una distribución eficiente.
- Aumentar la cantidad y velocidad de las salidas de aire con el uso de la producción independiente.
- Optimizar la distribución del aire y el consumo de combustible de los productos utilizados reduce de 250 / 300 l / ha.
- Dirige el flujo de aire y, en consecuencia, el producto directamente a la planta a tratar.
- Obtener la máxima cobertura, penetración y una más perfecta distribución.

"Control" patented

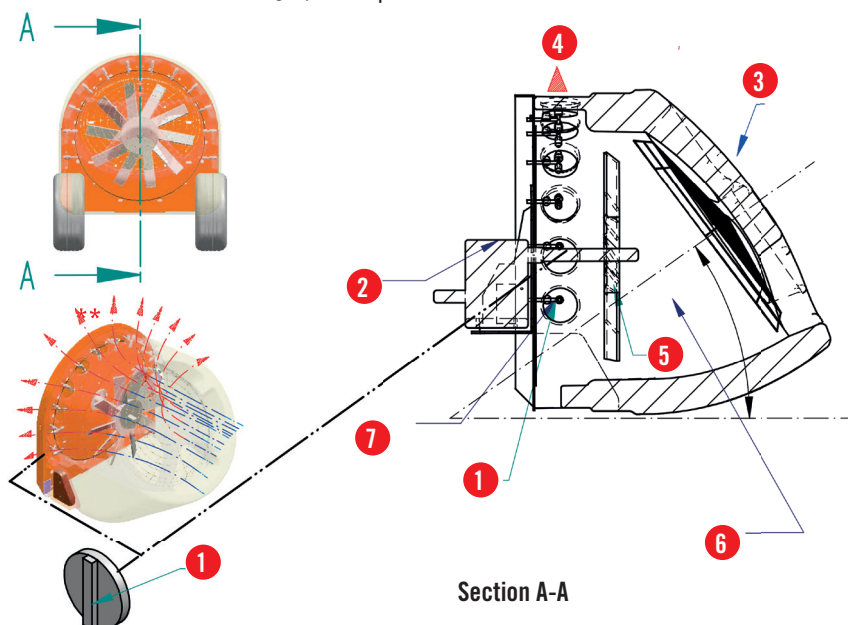

Section A-A

**IT** 1) TAPPO A BAIONETTA PER APERTURA CHIUSURA  
BOCCHETTONI 2) MULTIPLICATORE 3) INGRESSO ARIA  
DALL'ALTO 4) USCITA ARIA ALTA VELOCITA' 5) ELICA  
ORIENTABILE 6) ZONA ACCELERAZIONE ARIA 7) UGELLI

**GB** 1) PLUG BAYONET FOR OPENING AND CLOSING  
2) GEARBOX 3) INCOMING CLEAN AIR FROM THE TOP  
4) OUTPUTS WITH HIGH SPEED 5) ORIENTABLE  
PROPELLER 6) AREA OF AIR ACCELERATION 7) NOZZLES

**FR** 1) FERMETURE A BAIONETTE POUR OUVERTURE ET  
FERMETURE 2) MULTIPLICATEUR 3) AIR PROPRE ENTRANT  
PAR LE HAUT 4) SORTIE D'AIR AVEC HAUTE VITESSE  
5) HÉLICE À PAS VARIABLE 6) ZONE ACCELERATION  
DE L'AIR 7) BUSES

**DE** 1) BAJONETS SCHRAUBE FÜR OFFNEN UND SCHLISSEN  
2) GETRIEBE 3) SAUBERE LUFT MIT HOHER EINGANG 4) AIR  
AUSGANG MIT HOCHGESCHWINDIGKEIT 5) VERSTELL-  
PROPELLER 6) BESCHLEUNIGUNG LUFTGEBIET 7) DUESEN

**ES** 1) TAPONES A BAJONETA POR ABRIR Y SERRAR  
2) MULTIPLICADOR 3) AIRE LIMPIA CON ENTRADA DE ALTO  
4) SALIDA DE AIRE A ALTA VELOCIDAD 5) HÉLICE AJUSTABLE  
6) AREA DE ACCELERATION DE L'AIRE 7) BOQUILLAS



**DE VORTEILE:**

FORDERER AUS POLYETHYLEN MIT:  
DIE BESONDERE GEOMETRIE VERHINDERN  
DIE EINZUG IM FORDERWERK VON  
BLATTER, STAUF, ERDE UND DUNNEN STEIN UND  
DER SCHEIDEN DER KULTUREN VERMEIDEN.

UNHABHÄNGIGEN GEWERKSCHAFTEN FÜR DIE  
LUFTAUSGANG MIT OFFNEN UND SCHLIESSEN.  
DIE BAJONETTSSCHRAUBE GARANTIERE EINE  
GROSSE KANALIZATION DER LUFT.

SCHRAUBE MIT KLAPPUNG MIT 10KLIGEN UND  
GETRIEBE AUS GUSSEISEN.

DOPEL ANTI TROPFEN DUSEN. SIE  
REDUZIEREN DIE VERSCHWENDUNG DES  
PRODUKT.

**ES BENEFICIOS:**

CUBIERTA DE POLIETILENO CON BOCAS DE  
SALIDA DEL AIRE Y TAPONES DE CIERRE  
INDEPENDIENTES MEDIANTE TAPONES A  
BAYONETA QUE PERMITEN UNA MEJOR  
CANALIZACIÓN DEL AIRE

ENTRADA DE AIRE DELANTERO QUE  
IMPIDEN LA ENTRADA DE SUCIEDAD QUE  
PERJUDICA LA PLANTA

BOQUILLAS DOBLE ANTIGOTA QUE  
REDUCEN LA PERDIDA DE PRODUCTO



**1**



**2**



**3**



**4**



**5**



**6**



**7**

- IT** (1) PRODOTTO UTILE (2) ARIA INUTILE (3) ZONA NON COPERTA  
**GB** (1) USEFUL PRODUCT (2) USELESS AIR (3) NOT COVERED AREA  
**FR** (1) PRODUIT UTILE (2) AIR PAS UTILE (3) SECTION PAS COUVERTE  
**DE** (1) NUTZLICH PRODUCT (2) NUTZLOSS LUFT (3) AREA NICHT VERDECKT  
**ES** (1) PRODUCTO ÚTIL (2) AIRE INÚTIL (3) ÁREA NO CUBIERTA
- IT** (4) FLUSSO D'ARIA NEBULIZZATA A 20cm (5) NEBULIZZATA A 50 CM  
**GB** (4) AIR FLOW NEBULIZED AT 20 CM (5) NEBULIZED AT 50 CM  
**FR** (4) DÉBIT D'AIR DE PULVÉRISATION A 20 CM (5) PULVÉRISATION A 50 CM  
**DE** (4) LUFTSTROM SPRÜHEND AM 20 CM (5) SPRÜHEND AM 50 CM  
**ES** (4) FLUJO DE AIRE DE PULVERIZACIÓN A 20 CM (5) PULVERIZACIÓN A 50 CM
- IT** (6) BOCCHETTA E UGELLO APERTO (7) BOCCHETTA E UGELLO CHIUSO  
**GB** (6) OPENING AND NOZZLE OPEN (7) OPENING AND NOZZLE CLOSED  
**FR** (6) EMBOUT ET BUSE OUVERT (7) EMBOUT ET BUSE FERMÉ  
**DE** (6) EINWURF UND DUESE OFFNEN (7) EINWURF UND DUESE GESCHLOSSEN  
**ES** (6) ENCHUFE Y BOQUILLA ABIERTO (7) ENCHUFE Y BOQUILLA SERRADO

- IT** CONVENZIONALE **1** ASPIRA CORPI ESTRANEI **2** ARIA NEBULIZZATA CON POLVERI  
**GB** CONVENTIONAL **1** IT SUCKS FOREIGN PARTICLES **2** AIR NEBULIZED WITH DUST  
**FR** CONVENTIONNEL **1** IL ASPIRE DES CORPS ÉTRANGER **2** AIR PULVÉRISÉ AVEC POUSSIÈRES  
**DE** KONVENTIONELL **1** STREBT FREMDTEILCHEN **2** ZERSTÄUBER LUFT MIT PULVER  
**ES** CONVENCIONAL **1** ASPIRACION DE PARTÍCULAS EXTRAÑAS **2** AIRE ATOMIZADO COM POLVO

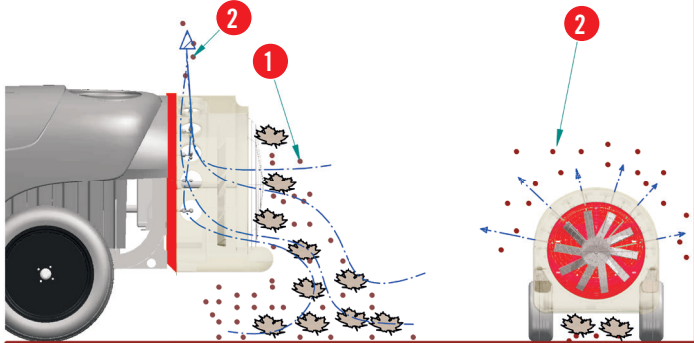

- CONTROL:** **1** ASPIRA ARIA PULITA **2** ARIA NEBULIZZATA SENZA POLVERI  
**CONTROL:** **1** CLEAN AIR SUCTION **2** NEBULIZED AIR WITHOUT DUST  
**CONTROL:** **1** ASPIRE L'AIR PROPRE **2** AIR NEBULISÉ SANS POUSSIÈRE  
**CONTROL:** **1** SAUGT SAUBERE LUFT **2** SPRUEHLUFT STAUBFREI  
**CONTROL:** **1** ASPIRA AIRE LIMPIO **2** AIRE PULVERIZADA LIBRE DE POLVO

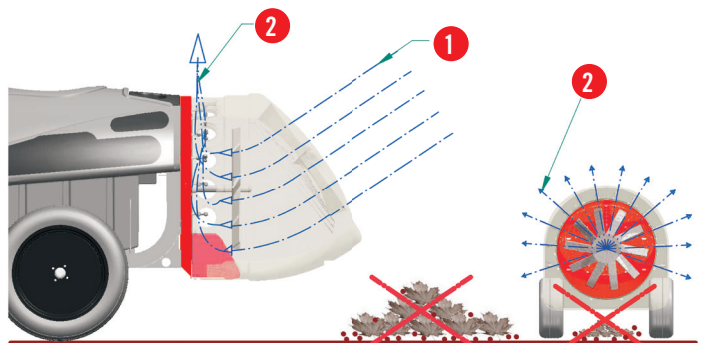

- GB** TEST OF VERTICAL DISTRIBUTION **FR** ESSAI DE DISTRIBUTION VERTICALE  
**DE** TEST VOM VERTIKALE VERTEILUNG **ES** PRUEBA DE DISTRIBUCIÓN VERTICAL  
**IT** BANCO PROVA VERTICALE DISTRIBUZIONE

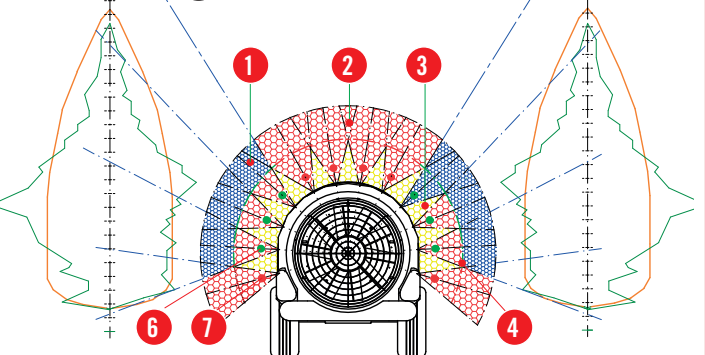

- GB** TEST OF VERTICAL DISTRIBUTION **FR** ESSAI DE DISTRIBUTION VERTICALE  
**DE** TEST VOM VERTIKALE VERTEILUNG **ES** PRUEBA DE DISTRIBUCIÓN VERTICAL  
**IT** BANCO PROVA VERTICALE DISTRIBUZIONE

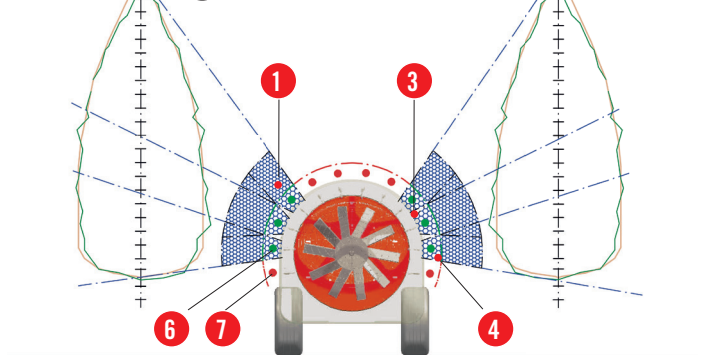

- GB** STEM PLANT CONFIGURATION **FR** CONFIGURATION PLANTES A TAMBOUR  
**DE** KONFIGURATION VON STAMMBAU **ES** CONFIGURACIÓN ARBOLES A TAMBOR  
**IT** CONFIGURAZIONE PIANTA A FUSTO

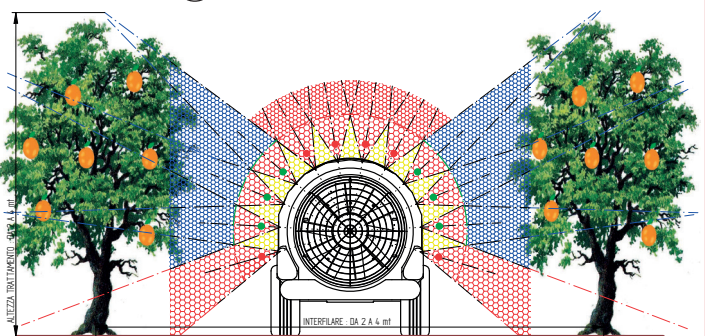

- GB** STEM PLANT CONFIGURATION **FR** CONFIGURATION PLANTES A TAMBOUR  
**DE** KONFIGURATION VON STAMMBAU **ES** CONFIGURACIÓN ARBOLES A TAMBOR  
**IT** CONFIGURAZIONE PIANTA A FUSTO

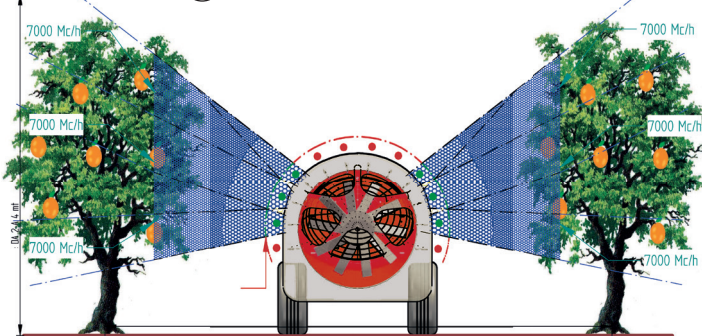

- GB** ESPALIER CONFIGURATION **FR** CONFIGURATION A ESPALIER  
**DE** KONFIGURATION VON ESPALIERANBAU **ES** CONFIGURACION ARBORES A ESPALDERA  
**IT** CONFIGURAZIONE A SPALLIERA

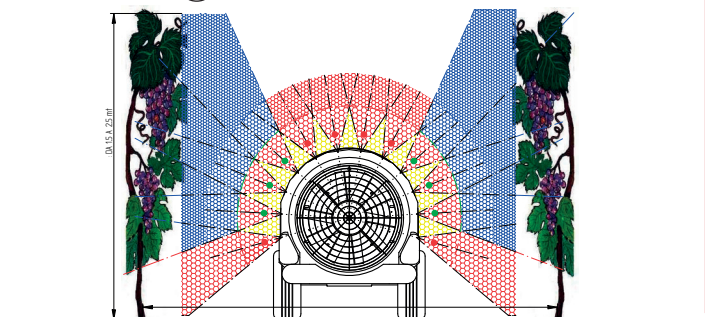

- GB** ESPALIER CONFIGURATION **FR** CONFIGURATION A ESPALIER  
**DE** KONFIGURATION VON ESPALIERANBAU **ES** CONFIGURACION ARBORES A ESPALDERA  
**IT** CONFIGURAZIONE A SPALLIERA

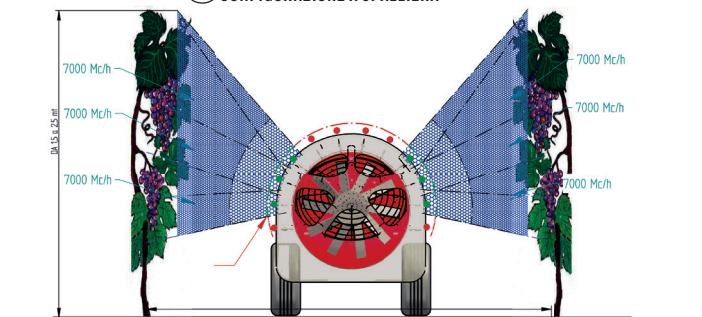



# POLI 70 New Control



## IT CARATTERISTICHE TECNICHE DI SERIE

MACCHINA MODULARE INTERCAMBIABILE

- CISTERNA IN POLIETILENE A SVUOTAMENTO TOTALE
- CISTERNA LAVACIRCUITO
- CISTERNA LAVAMANI
- LIVELLO ESTERNO
- TELAIO IN ACCIAIO VERNICIATO
- MOLTIPLICATORE AD INGRANAGGI
- ELICA BREVETTATA A PASSO VARIABILE AD INSERTI
- INDICATORE ESTERNO LIVELLO OLIO
- GETTI DOPPI IN OTTONE ANTIGOCCIA
- CONVOGLIATORE IN POLIETILENE "CONTROL"
- DISTRIBUTORE REGOLATORE DI PRESSIONE A DISTANZA SUL TELAIO (330/440) SUL TRATTORE (660/880/1100)
- FILTRO ASPIRAZIONE ESTERNO CON AUTORIEMPIMENTO
- ATTACCO AI TRE PUNTI SOLLEVATORE
- AGITATORE IDRAULICO
- 4 TAPPI CHIUSURA ARIA
- SENZA GIUNTO CARDANICO

## GB CURRENT TECHNICAL FEATURES

MODULATE AND INTERCHANGEABLE MACHINE

- POLYETHYLENE TANK WITH TOTAL EMPTYING
- TANK FOR CIRCUIT CLEANING
- TANK FOR HANDS CLEANING
- EXTERNAL LEVEL
- PAINTED STEEL FRAME
- GEARED OVERDRIVE
- PATENTED FAN VARIABLE PITCH PROPELLER WITH STRIPS
- EXTERNAL OIL LEVEL INDICATOR
- DOUBLE ANTI-DROP BRASS NOZZLES
- POLYETHYLENE CONVEYOR "CONTROL"
- REMOTE PRESSURE REGULATOR ON FRAME (330/440) ON THE TRACTOR (660/880/1100)
- OUTSIDE SUCTION FILTER WITH AUTOMATIC FILLING
- THIRD POINT COUPLING PINS
- HYDRAULIC AGITATOR
- NR. 4 CLOSING CAPS AIR
- WITHOUT CARDAN SHAFT

## FR CARACTERISTIQUES TECHNIQUES DE SERIE

APPAREIL MODULABLE INTERCHANGEABLE

- CUVE EN POLYETHYLENE COMPLETEMENT VIDANGEABLE
- CUVE RINCE-CIRCUIT
- CUVE LAVE-MAINS
- JAUGE EXTERIEUR
- CHASSIS EN ACIER PEINT
- MULTIPLICATEUR A ENGRANAGES
- VENTILATEUR A PAS VARIABLE ET EMBRAYAGE CENTRIFUGE
- INDICATEUR EXTERIEUR DE NIVEAU D'HUILE
- BUSES DOUBLES EN LAITON ANTI-GOUTTE
- CONVOYEUR EN POLYETHYLENE "CONTRÔLE"
- DISTRIBUTEUR ET REGULATEUR DE PRESSION A DISTANCE SUR LE CHASSIS (330/440) SUR LE TRACTEUR (660/880/1100)
- FILTRE ASPIRATION EXTERIEUR AVEC REMPLISSAGE AUTOMATIQUE
- ATTELAGE A 3 POINT
- AGITATEUR HYDRAULIQUE
- NR. 4 COUVERCLES DE FERMETURE POUR L'AIR
- SANS JOINT A CARDAN

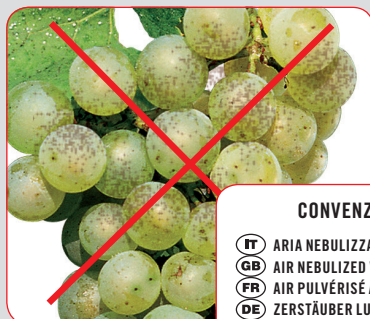

### CONVENZIONALE

- IT ARIA NEBULIZZATA CON POLVERI
- GB AIR NEBULIZED WITH DUST
- FR AIR PULVÉRISÉ AVEC POUSSIÈRES
- DE ZERSTÄUBER LUFT MIT PULVER
- ES AIRE ATOMIZADO COM POLVO

### CONTROL

- IT ARIA NEBULIZZATA SENZA POLVERI
- GB NEBULIZED AIR WITHOUT DUST
- FR AIR NEBULISÉ SANS POUSSIÈRE
- DE SPRUEHLUFT STAUBFREI
- ES AIRE PULVERIZADA LIBRE DE POLVO



**DE TECHNISCHE SERIENDATEN**

- MODULARE AUSTAUSCHBARE MASCHINE
- TANK AUS POLYAETHYLEN MIT TOTALENTLEERUNG
  - WASSERTANK ZUR REINIGUNG DER LEITUNGEN
  - FRISCHWASSERBEHÄLTER FÜR DAS BEDIENUNGSPERSONAL
  - PATENTIERTES FLÜGELRAD MIT EINSTELLABERER STEIGUNG UND EINSÄTZEN
  - EXTERNER ÖLSTANDANZEIGER
  - NIVEAUANZEIGER
  - STAHLRAHMEN LACKIERT
  - TROPFREIE DOPPELDUSEN AUS MESSING
  - ÜBERSETZUNGSGETRIEBE
  - FÖRDERER AUS POLYÄTHYLEN "CONTROL"
  - UMSCHALTEVENTIL MIT FERNSTEUERUNG AM RAHMEN (330/440) AM TRAKTOR (660/880/1100)
  - AEUSSERES ANSAUGFILTER MIT AUTOMATISCHER FUELLUNG
  - DREIPUNKTBEFESTIGUNGS BOLZEN
  - HYDRAYLISCHER RUEHRER
  - NR. 4 LUFTKLAPPEN FÜR SCHLIESSEN
  - OHNE KARDANGELENK

**ES CARACTERÍSTICAS TÉCNICAS DE SERIE**

- MAQUINA MODULAR INTERCAMBIABLE
- CISTERNA DE POLIETILENO A VACIAMIENTO TOTAL
  - CISTERNA LAVACIRCUITO
  - CISTERNA LAVAMANOS
  - NIVEL EXTERNO
  - CHASIS EN HIERRO PINTADO
  - HELICE PATENTADO DE PASO VARIABLE CON INSERTOS
  - INDICADOR EXTERNO DE NIVEL DE ACEITE
  - MULTIPLICADOR A ENGRANAJES
  - CHORROS DOBLES ANTIGOTA EN LATON
  - TRANSPORTADOR DE POLIETILENO "CONTROL"
  - DISTRIBUIDOR REGULADOR DE PRESION A DISTANCIA EN EL BASTIDOR (330/440) EN EL TRAZO (660/880/1100)
  - FILTRO ASPIRACION EXTERNO CON AUTOLLENADO
  - CRUCETAS ENGANCHE TERCERO PUNTO
  - AGITADOR HIDRAULICO
  - NR. 4 TAPONES PARA CERRAR EL AIRE
  - SIN JUNTA CARDANICA



STARMIX CONTROL									Mc/h					
	Lt	HP	Ø	N°	N°			RPM		Mt	A	B	C	Kg
330	300	25 - 30	700	12	10		1	540	30.000	3 - 4	1300	1000	1100	180
440	400	30 - 35	700	12	10		1	540	30.000	3 - 4	1300	1000	1300	185
440 B	400	30 - 35	700	12	10		1	540	30.000	3 - 4	1300	1300	1150	189
440	400	40 - 45	700	12	10		2	540	30 - 36.000	8 - 10	1300	1000	1300	212
440 B	400	40 - 45	700	12	10		2	540	30 - 36.000	8 - 10	1300	1300	1150	216
660	600	40 - 50	700	12	10		2	540	30 - 36.000	8 - 10	1750	1400	1300	268
660	600	55 - 60	800	10	12	●	2	540	33 - 42.000	10 - 12	1750	1400	1300	308
880	800	70 - 75	800	10	12	●	2	540	33 - 42.000	10 - 12	1750	1400	1450	313
1100	1000	85 - 90	900	10	14	●	2	540	33 - 48.000	10 - 12	1750	1400	1650	336



### IT CARATTERISTICHE TECNICHE DI SERIE

- MACCHINA MODULARE INTERCAMBIABILE
- CISTERNA IN POLIETILENE A SVUOTAMENTO TOTALE
  - CISTERNA LAVACIRCUITO
  - CISTERNA LAVAMANI
  - LIVELLO CISTERNA ESTERNO
  - TELAIO IN ACCIAIO VERNICIATO
  - MOLTIPLICATORE AD INGRANAGGI
  - ELICA IN NYLON
  - GETTI DOPPI ANTIGOCCIA IN OTTONE
  - CONVOGLIATORE IN POLIETILENE
  - DISTRIBUTORE REGOLATORE 3 VIE A DISTANZA SUL TELAIO
  - FILTRO ASPIRAZIONE ESTERNO PER L'AUTORIEMPIMENTO
  - AGITATORE IDRAULICO
  - ATTACCO AI TRE PUNTI SOLLEVATORE
  - SENZA GIUNTO CARDANICO

### GB CURRENT TECHNICAL FEATURES

- MACHINE MODULATE AND INTERCHANGEABLE
- POLYETHYLENE TANK WITH TOTAL EMPTYING
  - TANK FOR CLEANING-DEVICE CIRCUIT
  - TANK FOR CLEANING HAND
  - EXTERNALLEVEL
  - PAINTED STEEL FRAME
  - GEARED OVERDRIVE
  - NYLON PROPELLER
  - DOUBLE ANTI-DROP BRASS NOZZLES
  - POLYETHYLENE CONVEYOR
  - PRESSURE REGULATOR AND DISTRIBUTION ASSEMBLY 3 WAY ON FRAME
  - OUTSIDE SUCTION FILTER WITH AUTOMATIC FILLING
  - HYDRAULIC AGITATOR
  - CONNECTION TO THE THREE LIFTING POINTS
  - WITHOUT CARDAN SHAFT

### FR CARACTERISTIQUES TECHNIQUES DE SERIE











- APPAREIL MODULABLE INTERCHANGEABLE
- CUVE EN POLYETHYLENE COMPLETEMENT VIDANGEABLE
  - CUVE LAVE-CIRCUIT
  - CUVE LAVE-MAINS
  - JAUGE EXTERIEUR
  - CHASSIS EN ACIER PEINT
  - MULTIPLICATEUR A ENGRENAGES
  - VENTILATEUR EN NYLON
  - BUSES DOUBLES AVEC ANTIGOUTTE EN LAITON
  - CONVOYEUR EN POLYETHYLENE
  - DISTRIBUTEUR REGULATEUR 3 VOIES A DISTANCE SUR LE CHASSIS
  - FILTRE EXTERIEUR AVEC REMPLISSAGE AUTOMATIQUE
  - AGITATEUR HYDRAULIQUE
  - ATTELAGE A 3 POINTS ELEVATEUR
  - SANS TRANSMISSION A CARDAN

### DE TECHNISCHE SERIENDATEN

- MODULARE AUSTAUSCHBARE MASCHINE
- POLYÄTHYLEN TANK MIT TOTALENTLEERUNG
  - WASSERTANK ZUR REINIGUNG DER LEITUNGEN
  - FRISCHWASSERBEHÄLTER FÜR DAS BEDIENUNGSPERSONAL
  - NIVEAUANZEIGER
  - STAHLRAHMEN LACKIERT
  - ÜBERSETZUNGSGETRIEBE
  - NYLONFLÜGELRAD
  - TROPFREIE DOPPELDÜSEN AUS MESSING
  - FÖRDERER AUS POLYÄTHYLEN
  - UMSCHALTVENTIL MIT FERNSTEUERUNG AM RAHMEN
  - ÄUßERES ANSAUGFILTER MIT AUTOMATISCHER FÜLLUNG
  - HYDRAULISCHER RÖHRER
  - ANSCHLUSS AN DEN DREI STELLEN DES HEBERS
  - OHNE KARDANGELLENK

### ES CARACTERÍSTICAS TÉCNICAS DE SERIE

- MAQUINA MODULAR INTERCAMBIABLE
- CISTERNA DE POLIETILENO A VACIAMIENTO TOTAL
  - CISTERNA LAVACIRCUITO
  - CISTERNA LAVAMANOS
  - NIVEL EXTERNO
  - CHASIS EN HIERRO PINTADO
  - MULTIPLICADOR A ENGRANAJES
  - BASTIDOR EN NYLON
  - CHARROS DOBLES ANTIGOTA EN LATON
  - TRANSPORTADOR DE POLIETILENO
  - DISTRIBUTOR REGULADOR DE PRESSION A DISTANCIA EN EL BASTIDOR
  - FILTRO ASPIRACION EXTERNO CON AUTOLLENADO
  - AGITADOR HIDRAULICO
  - ENGANCHE EN LOS TRES PUNTOS ELEVADORES
  - SIN JUNTA CARDANICA

AP 50								Mch					
	Lt	HP	Ø	N°	N°		RPM	(m³)	Mt	A	B	C	Kg
220	200	25 - 30	500	12	10	1	540	24.000	3	1300	1000	950	207
330	300	25 - 30	500	12	10	1	540	24.000	3	1300	1000	1100	227
440	400	30 - 40	500	12	10	1	540	24.000	3	1300	1000	1300	237
440 B	400	30 - 40	500	12	10	1	540	24.000	3	1300	1300	1150	237

# AP Pneus

330 - 440 - 660

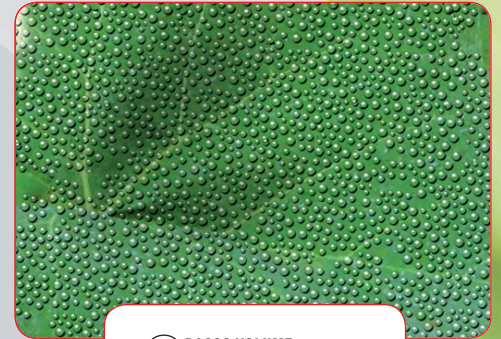

- IT BASSO VOLUME
- GB LOW VOLUME
- FR BAS VOLUME
- DE KLEINE AUSBRINGMENG
- ES BAJO VOLUME

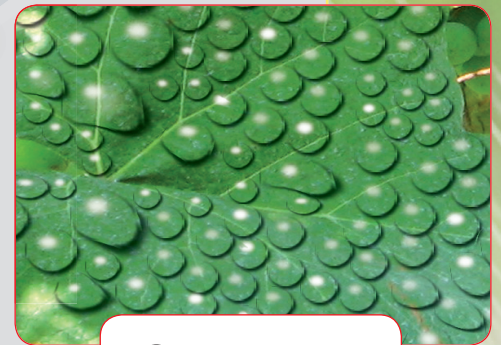

- IT VOLUME NORMALE
- GB NORMAL VOLUME
- FR VOLUME NORMAL
- DE NORMALE AUSBRINGMENG
- ES VOLUME NORMAL

## FR CARATTERISTICHE TECNICHE DI SERIE

- CISTERNA PRINCIPALE IN POLIETILENE
- CISTERNA LAVACIRCUITO
- CISTERNA LAVAMANI
- TELAIO IN ACCIAIO VERNICIATO
- INDICATORI DI LIVELLO ESTERNO
- AGITATORE IDRAULICO AD ALTA PRESSIONE
- FILTRO DI ASPIRAZIONE CON AUTORIEMPIMENTO
- MULTIPLICATORE DI GIRI AD INGRANAGGI A DUE VELOCITÀ CON FRIZIONE AD ESPANSIONE
- CONVOGLIATORE IN POLIETILENE
- ELICA RADIALE DA 500 MM
- DIFFUSORI A SNODI SFERICI ORIENTABILI
- DISTRIBUTORE E REGOLATORE DI PRESSIONE A DISTANZA SUL TELAIO MOD. UCM
- ATTACCO AI TRE PUNTI SOLLEVATORE
- SENZA GIUNTO CARDANICO

## GB CURRENT TECHNICAL FEATURES

- POLYETHYLENE MAIN TANK WITH "NO RESIDUE" FEATURE
- POLYETHYLENE HAND-WASHING TANK
- POLYETHYLENE CIRCUIT-WASHING TANK
- EXTERNAL LEVEL INDICATOR
- PAINTED STEEL FRAME
- HYDRAULIC AGITATOR
- SELF-FILLING INTAKE FILTER
- TWO SPEED OVERDRIVE GEAR
- POLYETHYLENE CONVEYOR WITH SINGLE OR DUAL OUTLET 500 MM Ø PROPELLER WITH CLUTCH
- REMOTE PRESSURE DISTRIBUTOR AND REGULATOR ON FRAME MOD. UCM
- CONNECTION TO THE THREE LIFTING POINTS
- WITHOUT CARDAN SHAFT

## FR CARACTERISTIQUES TECHNIQUES DE SERIE

- CUVE PRINCIPALE EN POLYETHYLENE COMPLETEMENT VIDANGEABLE
- CUVE LAVE-MAINS EN POLYETHYLENE
- CUVE LAVE-CIRCUIT EN POLYETHYLENE
- INDICATEURS DE NIVEAU EXTERNE
- CHASSIS EN ACIER PEINT
- AGITATEUR HYDRAULIQUE
- FILTRE D'ASPIRATION AVEC REMPLISSAGE AUTOMATIQUE
- MULTIPLICATEUR A ENGRANAGES A DEUX VITESSES
- AILERON EN POLYETHYLENE A SORTIE SIMPLE OU DOUBLE
- HELICE A EMBRAYAGE Ø 500 MM
- DISTRIBUTEUR ET REGULATEUR DE PRESSION A DISTANCE SUR LE CHASSIS MOD. UCM
- ATTELAGE A 3 POINTS ELEVATEUR
- SANS JOINT A CARDAN

## DE TECHNISCHE SERIENDATEN

- HAUPTTANK AUS POLYÄTHYLEN MIT TOTALENTLEERUNG
- POLYÄTHYLENTANK ZUM HÄNDEWASCHEN
- POLYÄTHYLENTANK FÜR DEN SPÜLKREISLAUF
- STAHLRAHMEN LACKIERT
- VERSTELLBARER STÜTZFUß
- HYDRAULISCHER RÖHRER
- ANSAUGFILTER MIT AUTOMATISCHER FÜLLUNG
- ZWEISTUFIGES ÜBERSETZUNGSGETRIEBE
- LEITFLÜGEL AUS POLYÄTHYLEN
- FLÜGELRAD MIT KUPPLUNG Ø 500 MM
- VERTEILER UND DRUCKREGLER MIT FERNBEDIENUNG AM SCHLEPPER MOD. UCM
- ANSCHLUSS AN DEN DREI STELLEN DES HEBERS
- OHNEKARDANGELENK

## ES CARACTERÍSTICAS TÉCNICAS DE SERIE

- CISTERNA PRINCIPAL DE POLIETILENO CON VACIAMIENTO COMPLETO
- CISTERNA LAVAMANOS DE POLIETILENO
- CISTERNA LAVACIRCUITO DE POLIETILENO
- INDICADORES DEL NIVEL EXTERNO
- CHASIS EN HIERRO PINTADO
- AGITADOR HIDRAULICO
- FILTRO DE ASPIRACION CON LLENADO AUTONOMO
- MULTIPLICADOR MEDIANTE ENGRANAJES CON DOS VELOCIDADES
- TRANSPORTADOR DE POLIETILENO CON UNA O DOS SALIDAS
- HELICE CON EMBRAGUE Ø500 MM.
- DISTRIBUIDOR REGULADOR DE PRESION A DISTANCIA EN EL BASTIDOR MOD. UCM
- ENGANCHE EN LOS TRES PUNTOS ELEVADORES
- SIN JUNTA CARDANICA

AP PNEUS							Mcl/h	mt/1"	A B C		KG	
	Lt	HP	Ø		Rpm	A						B
330	300	50-55	500	•	2	540	15.000	145	1070	1400	1000	207
440	400	55-60	500	•	2	540	15.000	145	1200	1400	1000	227
660	600	60-65	500	•	2	540	15.000	145	1220	1400	1410	247



# Turbo AP35

330 - 440 - 660



## IT CARATTERISTICHE TECNICHE DI SERIE

MACCHINA MODULARE INTERCambiabile

- CISTERNA IN POLIETILENE A SVUOTAMENTO TOTALE
- CISTERNA LAVACIRCUITO
- CISTERNA LAVAMANI
- LIVELLO ESTERNO
- TELAIO IN ACCIAIO VERNICIATO
- FILTRO ASPIRAZIONE CON AUTORIEMPIMENTO
- GETTI IN OTTONE ANTIGIOCCIA
- MOLTIPLICATORE AD INGRANAGGI
- DISTRIBUTORE E REGOLATORE DI PRESSIONE A DISTANZA SUL TELAIO
- INDICATORE ESTERNO LIVELLO OLIO
- AGITATORE IDRAULICO
- CONVOGLIATORE IN POLIETILENE ORIENTABILE MANUALMENTE
- VENTOLA CENTRIFUGA
- ATTACCO AI TRE PUNTI SOLLEVATORE
- SENZA GIUNTO CARDANICO

## GB CURRENT TECHNICAL FEATURES

MACHINE MODULATE AND INTERCHANGEABLE

- POLYETHYLENE TANK WITH TOTAL EMPTYING
- TANK FOR CLEANING CIRCUIT
- TANK FOR HAND CLEANING
- EXTERNAL LEVEL
- PAINTED STEEL FRAME
- OUTSIDE SUCTION FILTER WITH AUTOMATIC TANK FILLER
- DOUBLE BRASS ANTI-DROP NOZZLES
- GEARED OVERDRIVE
- EXTERNAL OIL LEVEL INDICATOR
- PRESSURE REGULATOR AND DISTRIBUTION ON FRAME
- HYDRAULIC AGITATOR
- POLYETHYLENE CONVEYOR WITH MANUALLY DIRECTED
- CENTRIFUGAL FAN
- THIRD POINT COUPLING PINS
- WITHOUT CARDAN SHAFT

## FR CARACTERISTIQUES TECHNIQUES DE SERIE

APPAREIL MODULABLE INTERCHANGEABLE

- CUVE EN POLYETHYLENE COMPLETEMENT VIDANGEABLE
- CUVE LAVE CIRCUIT
- CUVE LAVE MAINS
- JOUGE EXTERIEUR
- CHASSIS EN ACIER PEINT
- FILTRE ASPIRATION AVEC AUTO-REMPLISSAGE
- BUSES EN LAITON AVEC ANTI-GOUTTE
- MULTIPLICATEUR A ENGRANAGES
- INDICATEUR EXTERIEUR DE NIVEAU D'HUILE
- DISTRIBUTION ET REGULATEUR DE PRESSION A DISTANCE SUR CHASSIS
- AGITATEUR HYDRAULIQUE
- CONVEYEUR GALVANISEE A CHAUD ORIENTABLE MANUELLEMENT
- VENTILATEUR CENTRIFUGE
- ATTELAGE A 3 POINT
- SANS TRANSMISSION A CARDAN

## DE TECHNISCHE SERIENDATEN

MODULARE AUSTAUSCHBARE MASCHINE

- POLYÄTHYLEN TANK MIT TOTALENTLEERUNG
- ZUSÄTZLICHER WASSERTANK ZUR REINIGUNG DER FLÜSSIGKEIT FÜHRENDENLEITUNGEN
- ZUSÄTZLICHER FRISCHWASSER BEHÄLTER FÜR DAS BEDIENUNGSPERSONAL
- EXTERNER ÖLSTANDANZEIGER
- NIVEAUANYEIGER
- STAHLRAHMEN LACKIERT
- ÄUSSERER ABSAUGFILTER FÜR DIE SELBSTFÜLLUNG
- TROPFSCHUTZDÜSEN AUS MESSING
- ÜBERSETZUNGSSCHALTGETRIEBE
- 3 WEG UMSCHALTVENTIL AUF RAHMEN V HYDRAULISCHER WIRBLER
- MANUELL AUSRICHTBARER FÖRDERER AUS POLYÄTHYLEN
- ZENTRIFUGAL GEBLÄSE
- DREIPUNKTBEFESTIGUNGS BOLZEN
- OHNE KARDANWELLE

## ES CARACTERÍSTICAS TÉCNICAS DE SERIE

MAQUINA MODULAR INTERCambiabile

- CISTERNA DE POLIETILENO A VACIAMIENTO TOTAL
- CISTERNA LAVACIRCUITO
- CISTERNA LAVAMANOS
- NIVEL EXTERNO
- CHASIS EN HIERRO PINTADO
- FILTRO ASPIRACION CON AUTOLLENADO
- CHORROS DOBLES ANTIGOTA EN LATON
- MULTIPLICADOR A ENGRANAJES
- INDICADOR EXTERNO DE NIVEL DE ACEITE EN EL BASTIDOR
- AGITADOR HIDRAULICO
- TRANSPORTADOR EN POLIETILENO ORIENTABLE MANUALMENTE
- VENTILADOR CENTRIFUGO
- CRUCETAS ENGANCHE TERCERO PUNTO
- SIN JUNTA CARDANICA

TURBO AP 35											KG	
	Lt	HP	Ø	n°		Rpm	Mt	Mt	A	B	C	Kg
330	300	30-40	350	3+3	1	540	12-15	10-12	1600	1000	1400	262
440	400	35-45	350	3+3	1	540	12-15	10-12	1600	1200	1400	276
660	600	55-60	350	3+3	1	540	12-15	10-12	1600	1410	1620	290

# Turbo AP45

440 - 660 - 880 - 1100



## IT CARATTERISTICHE TECNICHE DI SERIE

- MACCHINA MODULARE INTERCambiabile
- CISTERNA IN POLIETILENE A SVUOTAMENTO TOTALE
  - CISTERNA LAVACIRCUITO
  - CISTERNA LAVAMANI
  - LIVELLO ESTERNO
  - TELAIO IN ACCIAIO VERNICIATO
  - FILTRO ASPIRAZIONE CON AUTORIEMPIMENTO
  - GETTI IN OTTONE "OR GIGANT" IN TESTATA
  - MOLTIPLICATORE AD INGRANAGGI
  - INDICATORE ESTERNO LIVELLO OLIO
  - DISTRIBUTORE E REGOLATORE DI PRESSIONE A DISTANZA SUL TRATTORE
  - AGITATORE IDRAULICO
  - CONVOGLIATORE IN POLIETILENE ORIENTABILE MANUALMENTE
  - VENTOLA CENTRIFUGA
  - ATTACCO AI TRE PUNTI SOLLEVATORE
  - SENZA GIUNTO CARDANICO

## GB CURRENT TECHNICAL FEATURES

- MACHINE MODULATE AND INTERCHANGEABLE
- POLYETHYLENE TANK WITH TOTAL EMPTYING
  - TANK FOR CLEANING CIRCUIT
  - TANK FOR HAND CLEANING
  - EXTERNAL LEVEL
  - PAINTED STEEL FRAME
  - OUTSIDE SUCTION FILTER WITH AUTOMATIC TANK FILLER
  - "OR GIGANT" BRASS NOZZLES
  - EXTERNAL OIL LEVEL INDICATOR
  - GEARED OVERDRIVE
  - PRESSURE REGULATOR AND DISTRIBUTION REMOTE FROM TRACTOR
  - HYDRAULIC AGITATOR
  - POLYETHYLENE CONVEYOR WITH MANUALLY DIRECTED
  - DOUBLE CENTRIFUGAL FAN
  - THIRD POINT COUPLING PINS
  - WITHOUT CARDAN SHAFT

## DE TECHNISCHE SERIENDATEN

- MODULARE AUSTAUSCHBARE MASCHINE
- POLYÄTHYLEN TANK MIT TOTALENTLEERUNG
  - WASSERTANK ZUR REINIGUNG DES FLÜSSIGKEIT FÜHRENDEN LEITUNGEN
  - ZUSÄTZLICHER FRISCHWASSER BEHÄLTER FÜR DAS BEDIE NUNGSPERSONAL
  - V NIVEAUANZEIGER
  - STAHLRAHMEN LACKIERT
  - ÄUSSERER ABSAUGFILTER FÜR DIE SELBSTFÜLLUNG V EXTERNER ÖLSTANDANZEIGER
  - TROPFFREIE DUESE AUS MESSING
  - ÜBERSETZUNGSSCHALTGETRIEBE
  - 3 WEG UMSCHALTVENTIL AUF TRAKTOR
  - HYDRAULISCHER WIRBLER
  - MANUELL AUSRICHTBARER FÖRDERER AUS POLYÄTHYLEN
  - ZENTRIFUGAL GEBLÄSE
  - OHNE KARDANWELLE

## ES CARACTERÍSTICAS TÉCNICAS DE SERIE

- MAQUINA MODULAR INTERCambiabile
- CISTERNA DE POLIETILENO A VACIAMIENTO TOTAL
  - CISTERNA LAVACIRCUITO
  - CISTERNA LAVAMANOS
  - NIVEL EXTERNO
  - CHASIS EN HIERRO PINTADO
  - FILTRO ASPIRACION CON AUTOLLENADO
  - CHORROS DOBLES ANTIGOTA EN LATON
  - MULTIPLICADOR A ENGRANAJES
  - INDICADOR EXTERNO DE NIVEL DE ACEITE
  - DISTRIBUTOR Y REGULADOR DE PRESSION A DISTANCIA EN EL TRACTOR
  - AGITADOR HIDRAULICO
  - TRANSPORTADOR EN DE POLIETILENO ORIENTABLE MANUALMENTE
  - DOBLE VENTILADOR CENTRIFUGO
  - CRUCETAS ENGANCHE TERCERO PUNTO
  - SIN JUNTA CARDANICA

## FR CARACTERISTIQUES TECHNIQUES DE SERIE APPAREIL MODULABLE INTERCHANGEABLE

- MODULABLE INTERCHANGEABLE
- CUVE EN POLYETHYLENE COMPLETEMENT VIDANGEABLE
  - CUVE LAVE CIRCUIT
  - CUVE LAVE MAINS
  - JOUGE EXTERIEUR
  - CHASSIS EN ACIER PEINT
  - FILTRE AVEC AUTO-REMPLISSAGE
  - BUSES EN LATON "OR GIGANT"
  - MULTIPLICATEUR A ENGRANAGES
  - INDICATEUR EXTÉRIEUR DE NIVEAU D'HUILE
  - DISTRIBUTEUR ET REGULATEUR DE PRESSION A DISTANCE SUR LE TRACTEUR
  - ATTACHE A 3 POINT
  - AGITATEUR HYDRAULIQUE
  - CONVEYEUR EN POLYETHYLENE ORIENTABLE MANUELLEMENT
  - DOUBLE VENTILATEUR CENTRIFUGE
  - SANS TRANSMISSION A CARDAN

TURBO AP 45													
	Lt	HP	Ø	n°			rpm	mt	mt	A	B	C	Kg
440	400	50 - 60 80 - 90	450	6 + 2	●	2	540	20 - 25 32 - 36	15 - 18 29 - 33	1600	1000	1650	341
660	600	50 - 70 80 - 90	450	6 + 2	●	2	540	20 - 25 32 - 36	15 - 18 29 - 33	1800	1400	1650	423
880	800	60 - 70 80 - 100	450	6 + 2	●	2	540	20 - 25 32 - 36	15 - 18 29 - 33	1800	1400	1650	435
1100	1000	70 - 90 90 - 120	450	6 + 2	●	2	540	20 - 25 32 - 36	15 - 18 29 - 33	1800	1400	1650	443



# Turbo AP45 Flex

660 - 880 - 1100



## IT CARATTERISTICHE TECNICHE DI SERIE

- MACCHINA MODULARE INTERCAMBIABILE
- CISTERNA IN POLIETILENE A SVUOTAMENTO TOTALE
- CISTERNA LAVACIRCUITO
- CISTERNA LAVAMANI
- LIVELLO ESTERNO
- TELAIO IN ACCIAIO VERNICIATO
- FILTRO ASPIRAZIONE CON AUTORIEMPIMENTO
- GETTI DOPPI ANTIGOCCIA IN OTTONE
- MOLTIPLICATORE AD INGRANAGGI
- INDICATORE ESTERNO LIVELLO OLIO
- DISTRIBUTORE E REGOLATORE DI PRESSIONE A DISTANZA SUL TRATTORE
- AGITATORE IDRAULICO
- CONVOGLIATORE IN POLIETILENE CON DOPPIA GIRANTE CENTRIFUGA CON TESTATA ORIENTABILE IDRAULICAMENTE
- VENTOLA CENTRIFUGA
- ATTACCO AI TRE PUNTI SOLLEVATORE
- TUBI IDRAULICI CON INNESTI RAPIDI (1 DOPPIO EFFETTO DEL TRATTORE)
- SENZA GIUNTO CARDANICO

## GB CURRENT TECHNICAL FEATURES

- MODULAR AND INTERCHANGEABLE MACHINE
- POLYETHYLENE TANK WITH TOTAL EMPTYING
- TANK FOR CLEANING CIRCUIT
- TANK FOR HAND CLEANING
- EXTERNAL LEVEL
- PAINTED STEEL FRAME
- OUTSIDE SUCTION FILTER WITH AUTOMATIC TANK FILLER
- DOUBLE BRASS ANTI-DROP NOZZLES
- GEARED OVERDRIVE
- EXTERNAL OIL LEVEL INDICATOR
- REMOTE PRESSURE REGULATOR AND DISTRIBUTION ON TRACTOR
- HYDRAULIC AGITATOR
- POLYETHYLENE CONVEYOR WITH DOUBLE CENTRIFUGAL IMPELLER WITH HYDRAULICALLY ADJUSTABLE HEAD
- CENTRIFUGAL FAN
- THIRD POINT COUPLING PINS
- HYDRAULIC HOSES WITH QUICK COUPLINGS (1 DOUBLE-ACTING TRACTOR CONTROL)
- WITHOUT CARDAN SHAFT

## FR CARACTERISTIQUES TECHNIQUES DE SERIE

- APPAREIL MODULABLE INTERCHANGEABLE
- CUVE EN POLYETHYLENE COMPLEMENTEMENT VIDANGEABLE
- CUVE LAVE-CIRCUIT
- CUVE LAVE-MAINS
- JAUGE EXTERIEUR
- CHASSIS EN ACIER PEINT
- FILTRE D'ASPIRATION AVEC AUTO-REMPLISSAGE
- BUSES EN LAITON DOUBLE
- MULTIPLICATEUR A ENGRANAGES
- INDICATEUR EXTERIEUR DE NIVEAU D'HUILE
- DISTRIBUTEUR ET REGULATEUR DE PRESSION A DISTANCE SUR LE TRACTEUR
- AGITATEUR HYDRAULIQUE
- CONVOYEUR EN POLYETHYLENE AVEC DOUBLE TURBINE CENTRIFUGE A CANON TELESCOPIQUE ORIENTABLE HYDRAULIQUEMENT
- VENTILATEUR CENTRIFUGE
- ATTELAGE A 3 POINT
- TUYAUX AVEC RACCORDS RAPIDES (1 DOUBLES EFFETS DE TRACTEURS)
- SANS JOINT A CARDAN











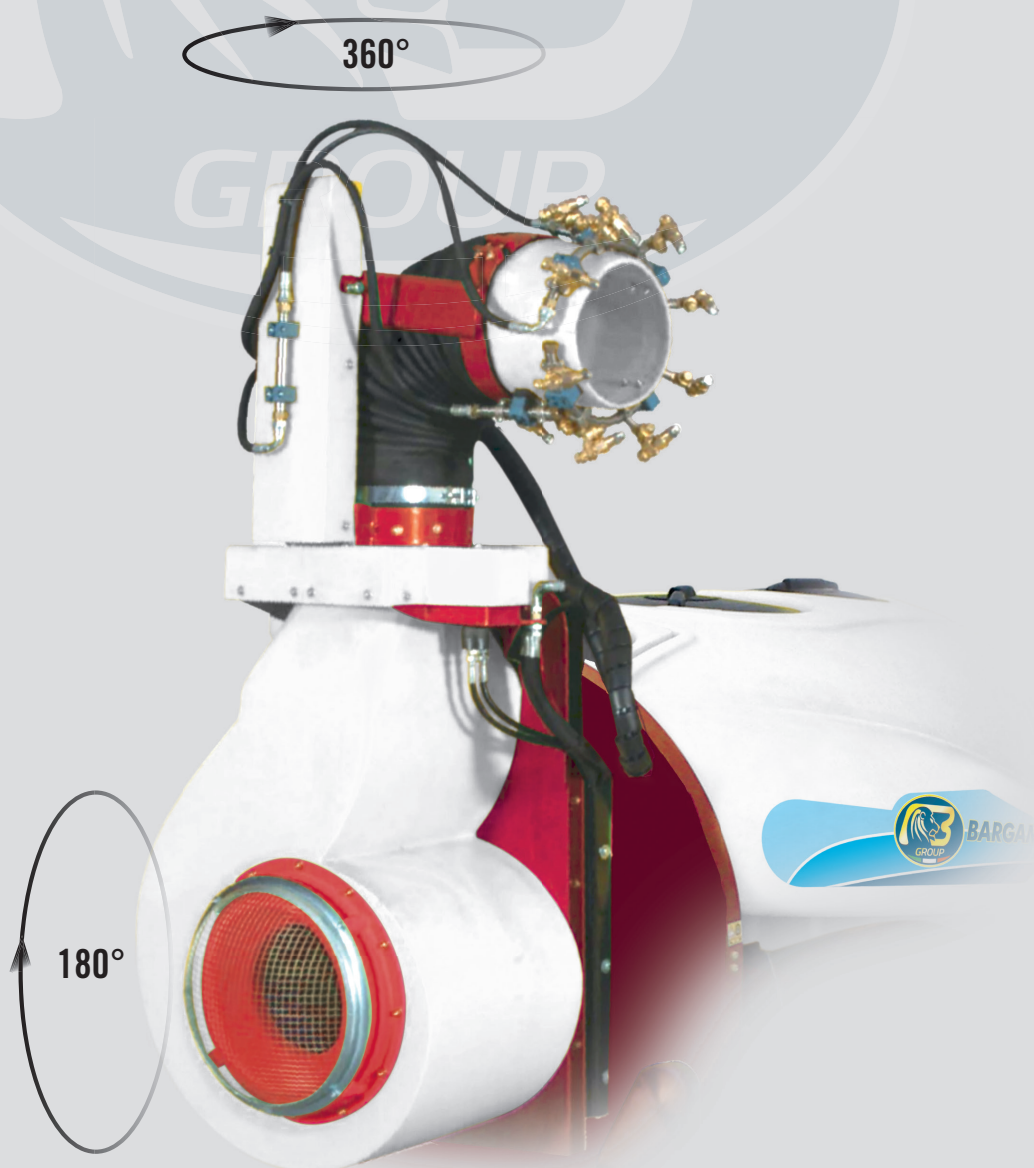



**ES CARACTERÍSTICAS TÉCNICAS DE SERIE**

- MÁQUINA MODULAR INTERCAMBIABLE
- CISTERNA DE POLIETILENO DE VACIAMIENTO TOTAL
  - CISTERNA LAVACIRCUITO
  - CISTERNA LAVAMANOS
  - NIVEL EXTERNO
  - CHASIS EN HIERRO PINTADO
  - FILTRO ASPIRACIÓN CON AUTOLLENADO
  - CHORROS DOBLES ANTIGOTA EN LATON
  - MULTIPLICADOR DE ENGRANAJES
  - INDICADOR EXTERNO DE NIVEL DE ACEITE
  - DISTRIBUIDOR Y REGULADOR DE PRESIÓN A DISTANCIA EN EL TRACTOR
  - AGITADOR HIDRÁULICO
  - TRANSPORTADOR DE POLIETILENO CON BOMBA CENTRÍFUGA DOBLE Y CABEZAL ORIENTABLE HIDRÁULICAMENTE
  - VENTILADOR CENTRÍFUGO
  - CRUCETAS ENGANCHE TERCERO PUNTO
  - TUBOS HIDRÁULICOS CON ENGANCHE RÁPIDO (1 DOBLE EFECTO DEL TRACTOR)
  - SIN JUNTA CARDÁNICA

**DE TECHNISCHE SERIENDATEN**

- MODULARE AUSTAUSCHBARE MASCHINE
- POLYÄTHYLEN-TANK MIT TOTALENTLEERUNG
  - WASSERTANK ZUR REINIGUNG DER FLÜSSIGKEITSFÜHRENDEN LEITUNG
  - ZUSÄTZLICHER FRISCHWASSER-BEHÄLTNER FÜR DAS BEDIENUNGSPERSONAL
  - NIVEAUANZEIGER
  - STAHLRAHMEN LACKIERT
  - ÄUSSERER ABSAUGFILTER FÜR DIE SELBSTFÜLLUNG
  - EXTERNER ÖLSTANDANZEIGER
  - TROPFFREIE DÜSEN AUS MESSING
  - ÜBERSETZUNGSSCHALTGETRIEBE
  - 3-WEG-UMSCHALTVENTIL AUF TRAKTOR
  - HYDRAULISCHER WIRBLER
  - FÖRDERER AUS POLYÄTHYLEN MIT DOPPELTEM ZENTRIFUGAL-LAUFRAD MIT HYDRAULISCH EINSTELLBAREM KOPF
  - ZENTRIFUGAL-GEBLÄSE
  - DREIPUNKTBEFESTIGUNGS BOLZEN
  - HYDR. SCHLÄUCHE MIT SCHNELLKUPPLUNGEN (1 DW HYDR. ANSCHLUSS AM TRAKTOR NOTWENDIG)
  - OHNE KARDANWELLE



TURBO AP 45 FLEX													
	Lt	HP	Ø	n°		rpm	mt	mt	A	B	C	Kg	
660	600	50 - 70 80 - 90	450	12	●	2	540	20 - 25 32 - 36	15 - 18 29 - 33	1800	1400	1950	526
880	800	60 - 70 80 - 100	450	12	●	2	540	20 - 25 32 - 36	15 - 18 29 - 33	1800	1400	1950	538
1100	1000	70 - 90 90 - 120	450	12	●	2	540	20 - 25 32 - 36	15 - 18 29 - 33	1800	1400	1950	546



# Turbo AP45 Flex Piralide

660 - 880 - 1100



## GB CARATTERISTICHE TECNICHE DI SERIE

MACCHINA MODULARE INTERCAMBIABILE

- CISTERNA IN POLIETILENE A SVUOTAMENTO TOTALE
- CISTERNA LAVACIRCUITO
- CISTERNA LAVAMANI
- LIVELLO ESTERNO
- TELAIO IN ACCIAIO VERNICIATO
- FILTRO ASPIRAZIONE CON AUTORIEMPIMENTO
- GETTI DOPPI ANTIGOCCIA IN OTTONE
- MOLTIPLICATORE AD INGRANAGGI
- INDICATORE ESTERNO LIVELLO OLIO
- DISTRIBUTORE E REGOLATORE DI PRESSIONE A DISTANZA SUL TRATTORE
- AGITATORE IDRAULICO
- CONVOGLIATORE IN POLIETILENE CON DOPPIA GIRANTE CENTRIFUGA CON CANNONE TELESCOPICO (DA 3,5 A 4,5M) E TESTATA ORIENTABILE IDRAULICAMENTE
- VENTOLA CENTRIFUGA
- ATTACCO AI TRE PUNTI SOLLEVATORE
- TUBI IDRAULICI CON INNESTI RAPIDI (1 DOPPIO EFFETTO DEL TRATTORE)

## IT CURRENT TECHNICAL FEATURES

MODULAR AND INTERCHANGEABLE MACHINE

- POLYETHYLENE TANK WITH TOTAL EMPTYING
- TANK FOR CLEANING CIRCUIT
- TANK FOR HAND CLEANING
- EXTERNAL LEVEL
- PAINTED STEEL FRAME
- OUTSIDE SUCTION FILTER WITH AUTOMATIC TANK FILLER
- DOUBLE BRASS ANTI-DROP NOZZLES
- GEARED OVERDRIVE
- EXTERNAL OIL LEVEL INDICATOR
- REMOTE PRESSURE REGULATOR AND DISTRIBUTION ON TRACTOR
- HYDRAULIC AGITATOR
- POLYETHYLENE CONVEYOR WITH DOUBLE CENTRIFUGAL IMPELLER WITH TELESCOPIC TUBE (FROM 3,5M TO 4,5M) AND HYDRAULICALLY ADJUSTABLE HEAD
- CENTRIFUGAL FAN
- THIRD POINT COUPLING PINS
- HYDRAULIC HOSES WITH QUICK COUPLINGS (1 DOUBLE-ACTING TRACTOR CONTROL)
- WITHOUT CARDAN SHAFT

## FR CARACTERISTIQUES TECHNIQUES DE SERIE

APPAREIL MODULABLE INTERCHANGEABLE

- CUVE EN POLYETHYLENE COMPLETEMENT VIDANGEABLE
- CUVE LAVE-CIRCUIT
- CUVE LAVE-MAINS
- JAUGE EXTERIEUR
- CHASSIS EN ACIER PEINT
- FILTRE D'ASPIRATION AVEC AUTO-REMPLISSAGE
- BUSES EN LAITON DOUBLE
- MULTIPLICATEUR A ENGRANAGES
- INDICATEUR EXTERIEUR DE NIVEAU D'HUILE
- DISTRIBUTEUR ET REGULATEUR DE PRESSION A DISTANCE SUR LE TRACTEUR
- AGITATEUR HYDRAULIQUE
- CONVOYEUR EN POLYETHYLENE AVEC DOUBLE TURBINE CENTRIFUGE A CANON TELESCOPIQUE (3,5M-4,5M) ORIENTABLE HYDRAULIQUEMENT
- ATTELAGE A 3 POINT
- TUYAUX AVEC RACCORDS RAPIDES (1 DOUBLES EFFETS DE TRACTEURS)
- SANS JOINT A CARDAN





**DE TECHNISCHE SERIENDATEN**

**MODULARE AUSTAUSCHBARE MASCHINE**

- POLYÄTHYLEN-TANK MIT TOTALENTLEERUNG
- WASSERTANK ZUR REINIGUNG DER FLÜSSIGKEITSFÜHREN DEN LEITUNG
- ZUSÄTZLICHER FRISCHWASSER-BEHÄLTER FÜR DAS BEDIENUNGSPERSONAL
- NIVEAUANZEIGER
- STAHLRAHMEN LACKIERT
- ÄUSSERER ABSAUGFILTER FÜR DIE SELBSTFÜLLUNG
- EXTERNER ÖLSTANDANZEIGER
- TROPFFREIE DÜSEN AUS MESSING
- ÜBERSETZUNGSSCHALTGETRIEBE
- 3-WEG-UMSCHALTVENTIL AUF TRAKTOR
- HYDRAULISCHER WIRBLER
- FÖRDERER AUS POLYÄTHYLEN MIT DOPPELTEM ZENTRIFUGAL-LAUFRAD MIT TELESKOPROHR (3,5 m - 4,5 m) UND HYDRAULISCH EINSTELLBAREM KOPF
- ZENTRIFUGAL-GEBLÄSE
- DREIPUNKTBEFESTIGUNGS BOLZEN
- HYDR. SCHLÄUCHE MIT SCHNELLKUPPLUNGEN (1 DW HYDR. ANSCHLUSS AM TRAKTOR NOTWENDIG)
- OHNE KARDANWELLE

**ES CARACTERÍSTICAS TÉCNICAS DE SERIE MÁQUINA**

**MODULAR INTERCAMBIABLE**

- CISTERNA DE POLIETILENO DE VACIAMIENTO TOTAL
- CISTERNA LAVACIRCUITO
- CISTERNA LAVAMANOS
- NIVEL EXTERNO
- CHASIS EN HIERRO PINTADO
- FILTRO ASPIRACIÓN CON AUTOLLENADO
- CHORROS DOBLES ANTIGOTA EN LATON
- MULTIPLICADOR DE ENGRANAJES
- INDICADOR EXTERNO DE NIVEL DE ACEITE
- DISTRIBUIDOR Y REGULADOR DE PRESIÓN A DISTANCIA EN EL TRACTOR
- AGITADOR HIDRÁULICO
- TRANSPORTADOR DE POLIETILENO CON BOMBA CENTRÍFUGA DOBLE DOTADA DE CAÑÓN TELESCÓPICO (3,5M-4,5M) Y CABEZAL ORIENTABLE HIDRÁULICAMENTE
- VENTILADOR CENTRÍFUGO
- CRUCETAS ENGANCHE TERCERO PUNTO
- TUBOS HIDRÁULICOS CON ENGANCHE RÁPIDO (1 DOBLE EFECTO DEL TRACTOR)
- SIN JUNTA CARDÁNICA

TURBO AP 45 FLEX PIRALIDE													
	Lt	HP	Ø	n°			rpm	mt	mt	A	B	C	Kg
660	600	50 - 70 80 - 90	450	12	●	2	540	20 - 25 32 - 36	15 - 18 29 - 33	1800	1400	3650	545
880	800	60 - 70 80 - 100	450	12	●	2	540	20 - 25 32 - 36	15 - 18 29 - 33	1800	1400	3650	557
1100	1000	70 - 90 90 - 120	450	12	●	2	540	20 - 25 32 - 36	15 - 18 29 - 33	1800	1400	3650	565



Imola - Sede principale



Jesi (Ancona) - Stabilimento produttivo



Manduria (Taranto) Stabilimento produttivo



## Bgroup Spa

Imola - Sede principale  
 Via Bicocca 16 - 40026 Imola (BO) - Italy  
 Tel. +39 0542 648511 - Fax +39 0542 640539  
 info@bgroup.info - www.bgroup.info

## Bgroup Spa

Jesi - Stabilimento produttivo  
 Via G.Pastore, 5/A - 60035 Jesi, (AN) - Italy

## Bgroup Spa

Manduria - Stabilimento produttivo  
 S.S. 7 TER Km 20 +300 Zona Industriale - 74024 Manduria (Taranto) - Italy

## Bgroup Spa

BARGAM UK LTD Platform One, Station Road, Duns TD11 3HS Berwickshire, GB  
 Tel 0044 01361 884288 - fax 0044 01361 882082  
 info@bargam.co.uk - www.bargam.co.uk



[www.Bgroup.info](http://www.Bgroup.info)

