

2017 big trailers series

platforms

ZACCARIA

QUALITY TRAILERS



platforms



Trailer with self-supporting covering MOD. 2C SUPER

3 height adjustable with PVC tarpaulin, side enlargements
PVC covering with enlargable roof.
Rear protection bar.



Round bales compression
side extension.

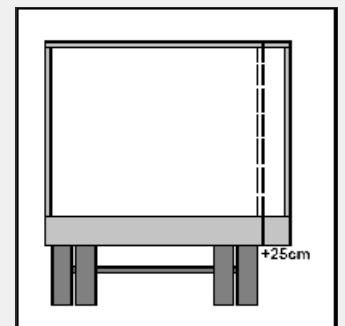
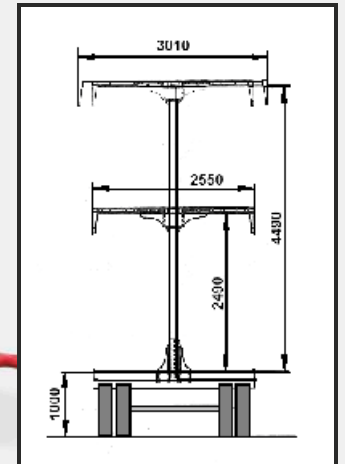

Rear extendible
column



trailer with self-supporting covering MOD. ZC

Adjustable height with PVC tarpaulin
3 height adjustable hydraulic columns
PVC covering with .xed roof.
Rear safety bar.

Optionals and accessories : :

- Rear colum extendible for loading (widht 2,55m).
- Front bar for round bales.
- Front bar for Bins.
- Self-powered independnt system for electro-hydraulic operations

On
trailer fitted
with
hydraulic ramps
rear chute lenght
40 cm,
height 2.50 m.

Cover designed with 3-D calculation and drawing system
Special high-strength steels
Made using laser cutting system
"Customized" models.

Standard equipment:

- Self steering rear axle.
- Fixed floor with slope.
- Hydraulic loading ramps 600x2200 mm.
- Adjustable ramps (inside measure 1250÷820)
- Hydraulic support device for ramps while loading.
- Parabolic leaf spring suspension.
- Tools box on chassis.
- Automatic brake adjuster (With pneumatic brake.)
- Mechanical loading winches.
- Retro reflecting rear panels and lateral lines.
- Extendable hydraulic drawbar.
- Industrial reinforced rims.
- Ramp operator side distributor.
- Steering adjuster.

On demand:

- Front bars for round bales.
- Front bar for bins.
- Patented round bales binding system.
- Hydraulic system to adjust the ramps distance.
- Double ramps mm. 600x2000+1200.
- Wide ramps mm. 750x2200 (inside measure 950÷520).
- Hydraulic winch. Special draw bar eye for export.

"Elegance" model:
 Wheel nut cap.
 Stainless steel tool box.
 Aluminium side coupling guard bars.
 Sides marker lights; LED headlights.

ZAM 200 EXTRA LONG with extendable hydraulic drawbar.
Floor length m. 10,85.
Loads 30 round bales.

PATENTED



Extendable hydraulic drawbar



Locked drawbar



Unlocked drawbar

MODEL	BODY SIZE cm.	AXLES	BRAKE SIZE	TARE Tons	GROSS W. Tons
ZAM 200 P extralong	1085x255	3	300x135	6.1	27.0
ZAM 200 I extralong	1085x255	3	industrial 10 col.	6.1	27.0

TYRES	TYRES ON REQUEST	PLATFORM H	BRAKE SYSTEM
215/75 R17.5 GEM Pirelli new H. platform cm. 92	245/70 R17.5 GEM Pirelli new	94	Pneumatic
	19.0/45-17 Single	102	Hydraulic
	445/45R 19.5 Single	106	

The maximum load capacity of trailers can be adapted in conformity with the regulations in force in your country.

platforms

2



ZAM 200 P MAXI

THREE AXLES TRAILERS WITH FRONT FIFTH-WHEEL COUPLING

Standard equipment:

- Self-steering rear axle.
- Fixed floor with slope.
- Hydraulic loading mm. 600x2200.
- Adjustable ramps (inside measure 1250÷820)
- Hydraulic support system for ramps while loading.
- Parabolic leaf spring suspensions.
- Tools box on chassis.
- Automatic brake adjuster (with pneumatic brake).
- Mechanical winches.
- Retro-reflecting rear panels and lateral lines.

On demand:

- Front bar for bins.
- Front bar for round bales.
- Patented round bales binding system
- Poles for round bales support.
- Hydraulic system for adjusting the ramps distance.
- Double ramps mm. 600x2000+1200.
- Wide ramps mm. 750x2200 (int. rampe 950÷520)
- Grid patterned ramps mm 1200x2200÷1200
- Double grid patterned ramps mm 1200x2200+1200
- Hydraulic winch. Special draw bar eye for export.

STANDARD: Steering adjuster.

"Elegance" model:
 Wheel cap nut. Stainless steel tool box
 Aluminium side coupling guard bars.
 Sides marker lights. LED headlights.



CURRENT TYRES

MODEL	BODY SIZE cm.	AXLES	BRAKE SIZE	TARE Tons	GROSS W. Tons	TYRES	PLATFORM H	BRAKE SYSTEM	
ZAM 200 P	850x255	3	300x135 industrial 10 col.	5.0	27.0	215/75 R17.5 twins Pirelli new	92	Pneumatic	
ZAM 200 I	850x255	3		5.0	27.0		on demand 245/70 R17.5 twins Pirelli new	94	Hydraulic
ZAM 200 P Super	980x255	3		5.5	27.0	19.0/45-17 new			102
ZAM 200 I Super	980x255	3		5.5	27.0			445/45R 19.5 new	
ZAM 200 P Maxi	1030x255	3		5.7	27.0	445/45R 19.5 new			106
ZAM 200 I Maxi	1030x255	3		5.7	27.0			Hydraulic	

215/75R17.5 New Twin L. 215 - H. 78
 245/70R17.5 New Twin L. 245 - H. 80
 19.0/45-17 New Twin L. 480 - H. 85
 445/45R19.5 New Twin L. 44.5 - H. 90



The maximum load capacity of trailers can be adapted in conformity with the regulations in force in your country.

platforms

3

PROFESSIONAL VERSION STANDARD: ELEGANCE EQUIPMENT



**ZAM 200 P MAXI
PROFESSIONAL**

PROFESSIONAL VERSION
Oversize axles and reinforced
structure for special loads.
Wooden stripes on platform.
New 245/70 R 17.5
Pirelli tyres with reinforced rims.

Standard: Elegance

MODEL	BODY SIZE cm.	AXLES	BRAKE SIZE	TARE Tons	GROSS W. Tons	TYRES	BRAKE SYSTEM
ZAM 200 P professional	850x255	3	300x135 industrial 10 col.	5.4	27.0	245/70 R17.5 twins new Pirelli Platform H.cm.94	Pneumatic
ZAM 200 I professional	850x255	3		5.4	27.0		Hydraulic
ZAM 200 P Super professional	980x255	3		5.9	27.0		Pneumatic
ZAM 200 I Super professional	980x255	3		5.9	27.0		Hydraulic
ZAM 200 P Maxi professional	1030x255	3		6.2	27.0		Pneumatic
ZAM 200 I professional	1030x255	3		6.2	27.0		Hydraulic

**ZAM 200 I
Maxi Professional**



The maximum load capacity of trailers can be adapted in conformity with the regulations in force in your country.

platforms

4



ZAM 200 ARP MAXI
Fitted with round bale binding system

ON DEMAND: Ramp operation side distributor

Certified hydraulic steering drawbar



THREE CLOSER AXLE TRAILERS

Standard equipment:

- Fixed floor with slope.
- Hydraulic ramps mm. 600x2200.
- Adjustable ramps (int. rampe 1250÷820)
- Hydraulic support system for ramps while loading.
- Self-steering rear and front axle.
- Parabolic leaf spring suspension with rocker arm.
- Tools box on chassis.
- Automatic brake adjuster (With pneumatic brake).
- Mechanical winches.
- Retro-reflecting rear panels and lateral lines.
- Brake corrector.

Accessories on demand:

- Central driving axle.
- Front bar for round bales.
- Double ramps mm. 600x2000+1200.
- Wide ramps mm. 750x2200 (int. rampe 950÷520)
- Hydraulic winch. Special draw bar eye for export.
- Patented round bales binding system.
- Poles for round bales support.

Elegance model:

- Wheel cap nut. Stainless steel box.
- Aluminium side coupling guard bars.
- Sides marker lights. LED headlights.

Customized models HYDRAULIC TRACTION

CURRENT TYRES

215/75R17.5 twin new 245/70R17.5 twin new 19.0/45-17 new 445/45R19.5 new
L. 215 - H. 78 L. 245 - H. 80 L. 480 - H. 85 L. 44.5 - H. 90



MODEL	BODY SIZE cm.	AXLES	BRAKE SIZE	TARE Q.li	GROSS W. Q.li	TYRES	PLATFORM H	BRAKE SYSTEM
ZAM 200 ARP 7	700x255	3	300x135 industrial 10 col.	4.3	27.0	215/75 R17.5 twin new Pirelli on demand	88	Pneumatic
ZAM 200 ARI 7	700x255	3		4.3	27.0			Hydraulic
ZAM 200 ARP	850x255	3		4.7	27.0	245/70 R17.5 twin Pirelli	91	Pneumatic
ZAM 200 ARI	850x255	3		4.7	27.0	19.0/45-17 Single new	93	Hydraulic
ZAM 200 ARP Maxi	980x255	3		5.5	27.0	445/45R 19.5 Single new		100
ZAM 200 ARI Maxi	980x255	3		5.5	27.0		Hydraulic	

The maximum load capacity of trailers can be adapted in conformity with the regulations in force in your country.

PROFESSIONAL VERSION
STANDARD:ELEGANCE EQUIPMENT

ZAM 200 ARP MAXI Professional
Equipped with double ramps



PROFESSIONAL VERSION
Oversized axles and structure
for heavy loads.
Wooden stripes on the loading platform
New tyres 245/70 R 17.5



ZAM 200 ARP Professional
equipped with
aluminium sides



ZAM 200 ARP MAXI suitable for logs
Equipped with double ramp and hydraulic steering drawbar

MODEL	BODY SIZE cm.	N. AXLES	BRAKE SIZE	TARE tons	GROSS WEIGHT tons	TYRES	BRAKE SYSTEM
ZAM 200 ARP 7 professional	700x255	3	300x135 industrial 10 col.	4.7	27.0	245/70 R17.5 Pirelli twins new H. platform cm.93	Pneumatic
ZAM 200 ARI 7 professional	700x255	3		4.7	27.0		Hydraulic
ZAM 200 ARP professional	850x255	3		5.1	27.0		Pneumatic
ZAM 200 ARI professional	850x255	3		5.1	27.0		Hydraulic
ZAM 200 ARP maxi professional	980x255	3		5.9	27.0		Pneumatic
ZAM 200 ARI maxi professional	980x255	3		5.9	27.0		Hydraulic

The maximum load capacity of trailers can be adapted in conformity with the regulations in force in your country.

platforms

6

Two axles with fifth-wheel coupling

Standard equipment:

Fixed floor with slope.
hydraulic loading ramps mm. 600x2200
Adjustable ramps (inside measure 1250÷820)
Hydraulic support system for ramps while loading
Parabolic leaf spring suspensions.
Tools box on chassis.
Automatic brake adjuster (with pneumatic brake).
Retro-reflecting rear panels and lateral lines.

On demand:

Front bar for round bales.
Patented round bales binding system
Poles for round bales support
Hydraulic system for adjusting the ramps distance.
Double ramps mm. 600x2000+1200
Wide ramps mm. 750x2200 (inside meas. 950÷520)
Hydraulic winch. Special draw bar eye for export.



ZAM 140 B Super
Patented round bales
binding system

Elegance equipment:

Wheel cap nut. STainless steel tool box.
Aluminium side coupling guard bars.
Sides marker lights. LED headlights.

MODEL	BODY SIZE cm.	AXLES	BRAKE SIZE	TARE tons	GROSS W. tons	TYRES	PLATFORM H	BRAKE SYSTEM
ZAM 140 A super	800x255	2	300x90 8 col.	3.8	20.0	215/75 R17,5 Pirelli twins new on request 245/70 R17,5 Pirelli twins new	92	Pneumatic
ZAM 140 B super	800x255	2		3.8	20.0		94	Hydraulic
ZAM 140 A Maxi	930x255	2		4.4	20.0	19.0/45-17 Single new	102	Pneumatic
ZAM 140 B Maxi	930x255	2		4.4	20.0	445/45R 19,5 Single new	106	Hydraulic

ZAM 60 P Super

Equipped with system for
fixing and tying round bales



Standard equipment:

Hydraulic loading ramps mm. 500x2000.
Adjustable ramps (inside measure 1050÷650).
External stands for manual ramps. Rear chute.
Ramp operation side distributor.

Super version:

Load capacity up to 9000 kg with reinforced frame and leaf spring.
Hydraulic braking for two axles.

On demand:

Front bar for round bales. Front bar for bins. Special draw bar eye for export.

MODEL	BODY SIZE cm.	AXLES	BRAKE SIZE	TARE tons	GROSS W. tons	TYRES	BRAKE SYSTEM	PLATFORM H. cm.
ZAM 60 P	650x245	2	300x90 8 col. rear axle	1.5	10.0	10.15 simple	Hydraulic	90
ZAM 60 P super	650x245	2	300x90 8 col.	2.0	10.0	215-75 R17.5 twins new	Hydraulic	90
ZAM 120 A	650x255	2	300x90 8 col.	2.2	12.0		Pneumatic	90
ZAM 120 B	650x255	2	300x90 8 col.	2.2	12.0		Hydraulic	90

The maximum load capacity of trailers can be adapted in conformity with the regulations in force in your country.

platforms

two tandem axles

7



**ZAM 140 ARI
Super**

ZAM 140 AR - ZAM 140 AR SUPER
also available in **TIPPING VERSION** with rear loading board and parabolic leaf spring suspension with rocker arm.

TWO-AXLE TANDEM TRAILERS

Standard equipment:
Fixed floor with slope.
Hydraulic ramps mm. 600x2200
Adjustable ramps (inside measures 1250÷820)
Hydraulic support system for ramp while loading.
Hydraulic self-steering rear axle.
Parabolic leaf spring suspensions.
Tools box on chassis.
Automatic brake adjuster (for pneumatic brake).
Mechanical winches.
Retro-reflecting rear panels and lateral lines.

On demand:

Driving front axle.
Front bars for round bales.
Double ramps mm. 600x2000 + 1200
Wide ramps mm. 750x2200 (inside measures 950÷520)
Hydraulic winch. Special draw bar eye for export.
Patented round bales binding system.
Poles for round bales support.
Hydraulic system for adjusting the ramps distance.
Hydraulic steering drawbar.

Elegance model:

Wheel nut cup. Stainless steel box.
Aluminium side coupling guard bars.
Side marker lamps. LED headlights.

STEERING DRAWBAR:

New optional features:

Hydraulically-controlled steering drawbar operated by tractor distributor
APPROVED

MODEL	BODY SIZE cm.	AXLES	BRAKE SIZE	TARE tons	GROSS W. tons	TYRES	PLATFORM H	BRAKE SYSTEM
ZAM 140 ARP	650x255	2	300x90 8 col.	3.0	20.0	215/75 R17,5 Pirelli twins new	88	Pneumatic
ZAM 140 ARI	650x255	2		3.0	20.0	on request 245/70 R17,5 Pirelli twins new	91	Hydraulic
ZAM 140 ARP super	800x255	2		3.6	20.0	19.0/45-17 Single new	93	Pneumatic
ZAM 140 ARI super	800x255	2		3.6	20.0	445/45R 19,5 Single new	100	Hydraulic

The maximum load capacity of trailers can be adapted in conformity with the regulations in force in your country.

platforms

8 Two tandem axles



ZAM 120 ARI

ZAM 120 ARP/ARI RIB TRAILERS also available in TIPPING VERSION
with rear loadingboard and cantilever spring suspensions.



TWO-AXLES TANDEM SERIES 120

Standard equipment:

- Fixed floor with slope.
- Hydraulic ramps mm. 500x2000.
- Adjustable ramps (inside measure 1050÷650)
- External stands for manual ramps.
- Parabolic leaf spring suspensions with rocker arm.
- Tools box on chassis.
- Mechanical winches.
- Ramp operation side distributor.

On request:

- Front driving axle.
- Front bars for round bales or bins.
- Special draw bar eye for export.
- Coil floor on the slope.
- Hydraulic winch. Poles for round bale support.
- Patented round bales binding system.
- Hydraulic steering drawbar.

MODEL	BODY SIZE cm.	AXLES	BRAKE SIZE	TARE tons	GROSS W. tons	TYRES	PLATFOR. H	BRAKE SYSTEM
ZAM 120 ARP	650x255	2	300x90 8 col.	3.0	16.0	215/75 R17.5 twins used on request 215/75 R17.5 twins new 400/60-15.5 new	88	Pneumatic
ZAM 120 ARI	650x255	2		3.0	16.0			Hydraulic
ZAM 120 ARP RIB	650x255	2	300x90 8 col.	3.0	16.0	215/75 R17.5 twins used on request 215/75 R17.5 twins new 400/60-15.5 new	88	Pneumatic
ZAM 120 ARI RIB	650x255	2		3.0	16.0			Hydraulic

The maximum load capacity of trailers can be adapted in conformity with the regulations in force in your country.

Platforms for industrial use

13 mt. platform
Load 40 Tons.



ZAM 200 ARP Professional
with Zaccaria crane F8500.



ZAM 200 P SUPER 4 AXLES VERSION
Working capacity 40000 kg.



ZAM 200 ARP with hydraulic traction



ZAM 140 P Super
Outfitted for transporting live animals

Our technical department designs using calculation software and 3D drawing "Big trailers" equipment. A dedicated office tests Operating Machines and Oversize load vehicles, according to Italian and European standards.



Trailer with coverings
Various models and hydraulic ramps

- Customized Models
- HYDRAULIC TRACTION

ZACCARIA

QUALITY TRAILERS



zaccariamorchi.com



ZACCARIA SRL

Via Enrico Fermi, 350

I - 41055 Montese (Modena) - Italy

Tel. +39 (0)59 981750

Fax: +39 (0)59 982353

www.zaccariamorchi.com

info@zaccariamorchi.com

 www.facebook.com/zaccariamorchi

 www.linkedin.com/company/zaccaria-srl

 www.youtube.com/channel/UCe9-IOXLYuqygcinU1n51jA

Subsidiaries and Warehouses:

I - 41015 Nonantola (Modena)

Via Zuccola, 12 - Italy

I - 41057 Spilamberto (Modena)

Piazza Beccadori, 4 - Italy

