



# *bravo*350

**BRAVO 350 SERIES COMPUTER  
CROP SPRAYING  
DIRECT CONNECTION**

**CE**

**4673505XXX  
4673507XXX**

Software rel. 1.1.x

**INSTALLATION, USE AND MAINTENANCE**

 = **Generic danger**

 = **Warning**

• Legend of symbols .....	2	9.8 Speed.....	30
• Manual foreword and use .....	4	9.8.1 Source - Wheel sensor.....	31
• Manual use modes.....	4	9.8.2 Source - GPS.....	31
• LIMITATIONS .....	4	9.9 Flowrate correction factor .....	32
• Responsibility .....	4	9.10 Press. sensor zero value .....	32
<b>1 Risks and protections before assembly .....</b>	<b>4</b>	9.11 Totalizers.....	32
<b>2 Intended use.....</b>	<b>4</b>	9.12 Test .....	33
<b>3 Precautions .....</b>	<b>4</b>	9.12.1 Speed simulation.....	33
<b>4 Package content .....</b>	<b>5</b>	9.12.2 Signal test.....	33
<b>5 System recommended composition .....</b>	<b>5</b>	9.12.3 Battery voltage.....	33
5.1 Monitor position.....	6	9.12.4 Display.....	33
5.2 Bracket fixing .....	6	9.12.5 Keyboard & Switches .....	34
5.3 Control unit position .....	6	9.12.6 GPS data.....	34
5.4 Hydraulic unit positioning .....	6	9.12.7 Monitor hardware version - Monitor software version.....	34
<b>6 Wiring connections.....</b>	<b>7</b>	9.13 User preferences .....	35
6.1 General precautions for a correct harness position .....	7	9.13.1 Sound alarm.....	35
6.2 Power supply connection .....	7	9.13.2 Sound keyboard .....	35
6.3 Connection of multicore connector .....	8	9.13.3 Date & Time.....	35
6.4 Control unit valve connection.....	8	9.13.4 Display contrast.....	35
6.5 Hydraulic valve connection .....	9	9.13.5 Filling calculation .....	35
6.6 Connection of sensors and available functions.....	10	9.13.6 Data display.....	35
6.7 Power supply connection .....	10	9.14 Data logger .....	36
<b>7 Setting.....</b>	<b>11</b>	9.15 Ext. device log.....	37
7.1 Tests and checks before setting.....	11	9.16 Load/save setup.....	37
7.2 Computer switching on/off .....	11	9.16.1 Load configuration from USB .....	37
7.3 Use of keys for setting .....	12	9.16.2 Save configuration to USB .....	37
<b>8 Advanced setup .....</b>	<b>14</b>	9.16.3 Restore factory .....	37
8.1 Sections configuration.....	16	<b>10 Use .....</b>	<b>38</b>
8.2 Boom setup.....	16	10.1 Controls on computer.....	38
8.3 Valves configuration.....	17	10.2 Control, selection or modification keys (1 - 2 Fig. 73).....	38
8.4 Flowmeter .....	18	10.3 Switches to operate valves in the control unit (3 Fig. 73) .....	38
8.5 Pressure sensor.....	18	10.4 Switches to use the hydraulic functions (4 Fig. 73).....	38
8.6 Flowrate calculation sensor .....	18	10.5 Display .....	39
8.7 Tank level.....	19	10.6 Treatment preliminary settings.....	39
8.7.1 Tank level - Manual Mode .....	19	10.7 Application rate regulation .....	40
8.7.2 Tank level - Level sensor mode.....	19	10.7.1 Automatic operation.....	40
8.7.3 Tank level - Filling flowmeter mode .....	20	10.7.2 Manual operation (DEFAULT) .....	40
8.8 Revolutions counter .....	21	10.7.3 Automatic closure of section and main valves (via Bravo 400S / Delta 80).....	40
8.9 Foam Marker.....	21	<b>11 Maintenance / diagnostics / repairs .....</b>	<b>41</b>
8.10 External device .....	21	11.1 Cleaning rules .....	41
8.11 Access level.....	22	11.2 Operation errors.....	41
8.12 Setup check after Advanced setup end .....	23	11.3 Troubleshooting .....	42
<b>9 User setting .....</b>	<b>24</b>	<b>12 Accessories.....</b>	<b>42</b>
9.1 Job selection.....	26	12.1 Pendrive.....	42
9.2 Current Job data .....	26	<b>13 Technical data .....</b>	<b>43</b>
9.3 Jobs setup.....	26	13.1 Computer technical data .....	43
9.4 Nozzles setup .....	27	13.2 Pin-out of Bravo 350 .....	43
9.5 Working parameters.....	28	<b>14 Guarantee terms .....</b>	<b>45</b>
9.5.1 Task Controller TC.....	28	<b>15 End-of-life disposal .....</b>	<b>45</b>
9.5.2 Nozzles wear check.....	28		
9.5.3 Min. spraying speed .....	28		
9.5.4 Regulation lock type.....	28		
9.6 Rate controller.....	28		
9.7 Tank .....	29		

## • **MANUAL FOREWORD AND USE**

This manual provides instructions to assemble, connect and set the computers of the BRAVO 350 family. Any other information is provided in specific sheets to be used exclusively by the installer, containing specific information of each computer model.

## • **MANUAL USE MODES**

The section of this manual dedicated to the installation contains information for installers. For this reason we have used technical terms without providing explanations which would be necessary for end users only.

**THE INSTALLATION MUST BE CARRIED OUT BY AUTHORIZED AND SKILLED PERSONNEL ONLY. THE MANUFACTURER IS NOT RESPONSIBLE FOR ANY OPERATION SPECIFIED IN THIS MANUAL CARRIED OUT BY UNAUTHORIZED OR UNSKILLED PERSONNEL.**

## • **LIMITATIONS**

The descriptions of the assembly phases refer to a "general" computer, so specific models will not be mentioned, unless a certain installation procedure concerns exclusively one computer type.

## • **RESPONSIBILITY**

The installer must carry out workmanlike installations and ensure to the end user the perfect operation of the whole system both with ARAG components only and other brands' components.

ARAG always recommends using its components to install control systems.

The installer will be held responsible for any malfunction if he decides to use other brands' components even without actually changing the system parts or harness.

The compatibility check with components and accessories of other manufacturers shall be carried out by the installer.

If the computer or the ARAG components installed together with other brands' components get damaged because of what stated above, no direct or indirect warranty will be provided.

## **1 RISKS AND PROTECTIONS BEFORE ASSEMBLY**

**All installation works must be done with battery disconnected, using suitable tools and any individual protection equipment deemed necessary.**

 **Use ONLY clean water for treatment tests and simulations: using chemicals during simulated treatment runs can seriously injure persons in the vicinity.**

## **2 INTENDED USE**

The device you have purchased is a computer which, when connected to a valve or suitable control unit, makes it possible to control all phases of treatment in agricultural applications directly from the cabin of the farming machine it is installed in.

 **This device is designed to work on agricultural machinery for spraying and crop spraying applications. The equipment is designed and manufactured in compliance with UNI EN ISO 14982 standard (Forestry and farming machines - Electromagnetic compatibility - Test methods and acceptance criteria), harmonized with EMC - 2014/30/EU Directive.**

## **3 PRECAUTIONS**

-  • Do not aim water jets at the equipment.  
 • Do not use solvents or fuel to clean the case outer surface.  
 • Do not clean equipment with direct water jets.  
 • Comply with the specified power voltage (12 VDC).  
 • In case of voltaic arc welding, remove connectors from BRAVO 350 and disconnect the power cables.  
 • Only use ARAG genuine spare parts and accessories.  
 • Bravo 350 can control hydraulic valves to open / close the job boom.

 **THE COMPUTER DOES NOT FEATURE EMERGENCY STOP DEVICES: THE MACHINE MANUFACTURER MUST PROVIDE ALL NECESSARY SAFETY DEVICES FOR THE HYDRAULIC VALVE CONTROL. IT IS THE MANUFACTURER'S RESPONSIBILITY TO ENSURE THAT THE MACHINE IS SAFE TO USE, ALSO BY MEANS OF ACOUSTIC AND/OR VISUAL SIGNALING DEVICES.**

4 PACKAGE CONTENT



Fig. 1

- 1 Bravo 350 with direct connection
  - 2 Power cable length 3m
  - 3 Power supply connector
  - 4 Connection cable for:  
BRAVO 350 - Sensors - Control unit (main valve + control valve + section valves)
  - 4a Seals for control unit valve connectors
  - 5\* Hydraulic unit harness
  - 5a\* Seals for hydraulic unit valve connectors
  - 6 Safety covers for control unit valve connectors (no. 2 for 5-way version ONLY)
  - 7 Fixing kit
- \* for versions with hydraulic functions ONLY



Sensors, control units and accessories must be ordered separately (Ref. ARAG general catalog).

5 SYSTEM RECOMMENDED COMPOSITION

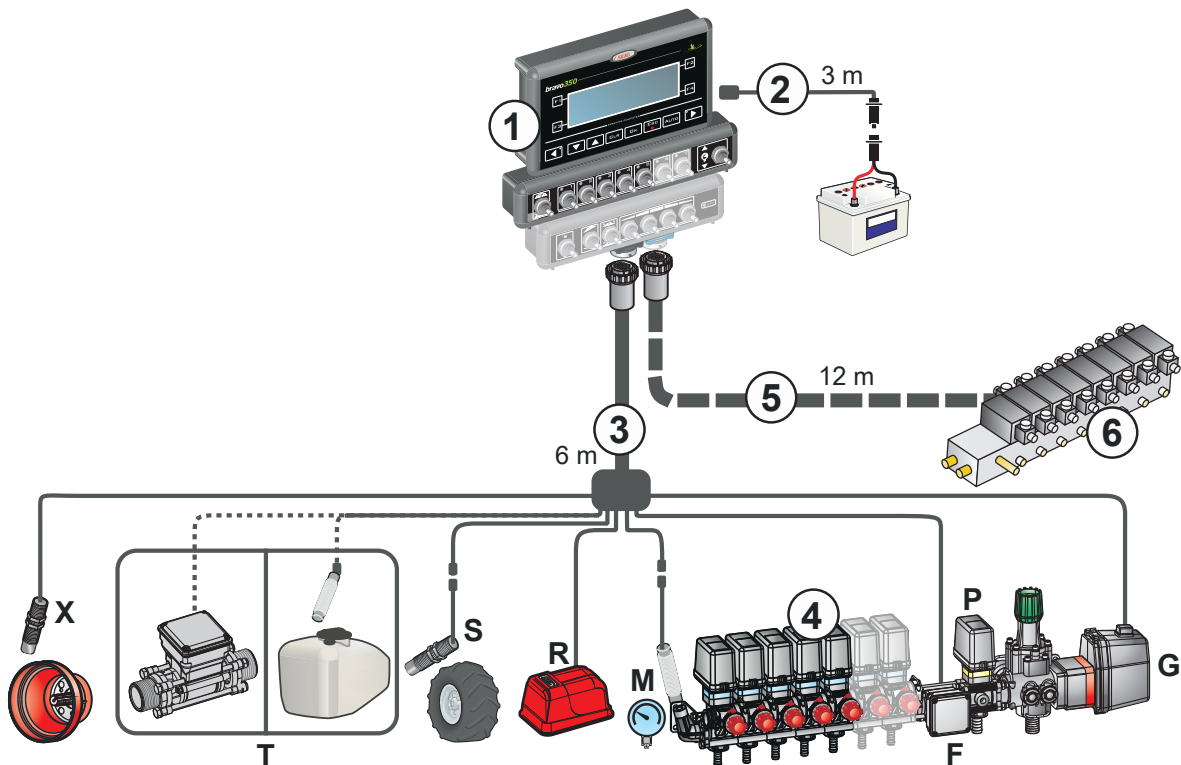

Fig. 2

Legend:

- 1 Bravo 350 with direct connection
- 2 Power cable for Bravo 350
- 3 Connection cable for:  
BRAVO 350 - Sensors - Control unit (main valve + control valve + section valves)
- 4 Control unit (G main valve + P control valve)
- 5\* Connection cable for hydraulic valves (if available on the system)
- 6\* Hydraulic control unit (if available on the system, not supplied in the kit to be purchased separately)

Sensors:

- X RPM sensor
- T Filling flowmeter or Level sensor
- S Speed sensor
- R Foam marker
- M Pressure sensor
- F Flowmeter

## 5.1 Monitor position

Bravo 350 must be placed in the control cabin of the farming machine. Observe the following precautions:

- ⚠ - Do NOT install the monitor in areas where it would be subjected to excessive vibrations or shocks, to prevent any damage or accidental use of the control keys;
- Install the device in a visible position within easy reach by hand; bear in mind that the monitor should not obstruct the operator's freedom of movement or block his view.

✋ Consider all necessary connections of the computer (chap. 5), the cable length, and make sure there is enough space for connectors and cables.  
An identification symbol is located next to each connector to indicate its function. For any reference to the system configuration read chap. 5.

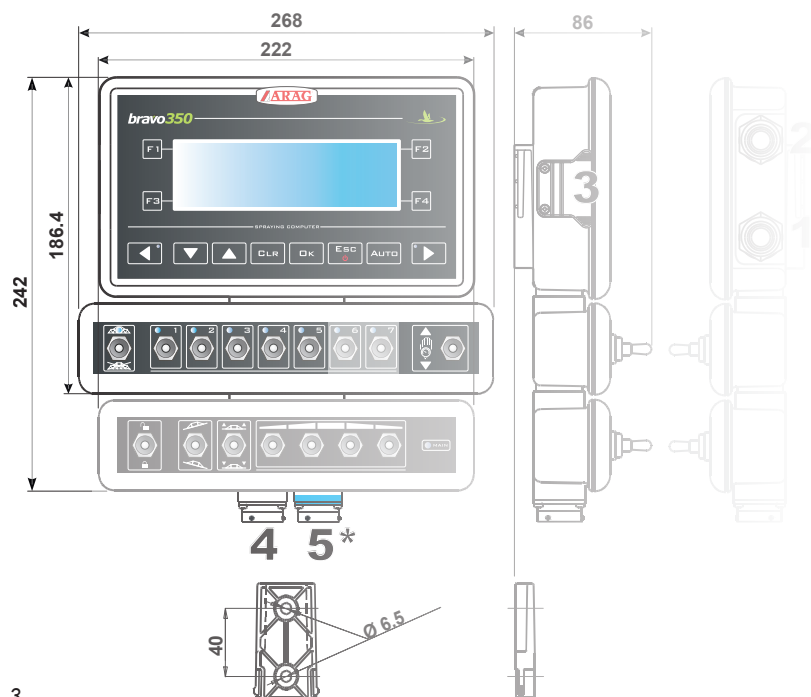

Fig. 3

No.	Monitor connection points
1	Monitor power supply
2	Auxiliary connections
3	USB
4	Control units and sensors
5*	Hydraulic unit

\* for versions with hydraulic functions ONLY

## 5.2 Bracket fixing

The monitor must be mounted after having fixed the bracket at the desired location (the previous paragraph shows the bracket drilling template). The bracket must be slid out of the monitor seat (A, Fig. 4) and fixed using the supplied screws (B).

**Make sure the bracket is securely mounted, fit the monitor on it, and push it until it locks in place (C).**

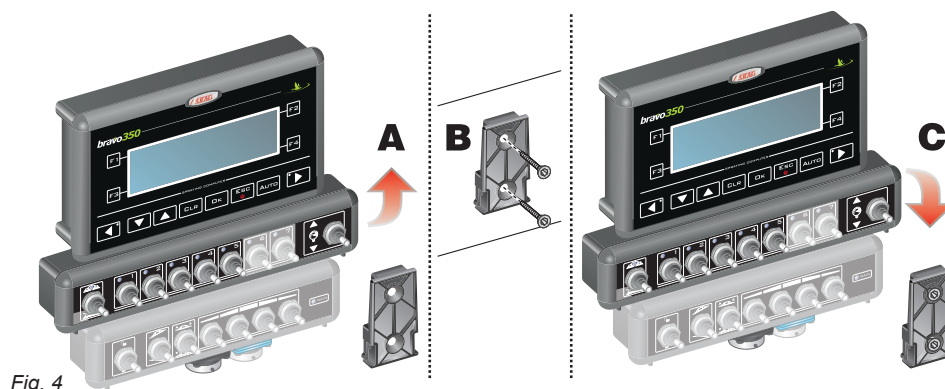

Fig. 4

## 5.3 Control unit position

The control unit must be fixed with the special brackets supplied and fitted to the unit, positioning it as shown in the manual provided with the assembly.

- ⚠ **MAKE SURE TO FOLLOW ALL THE SAFETY INSTRUCTIONS GIVEN IN THE CONTROL UNIT'S MANUAL.**

## 5.4 Hydraulic unit positioning

The hydraulic unit shall be secured to the machine, making sure it is well protected against the elements and the fluid sprayed by the machine.

✋ **ARAG IS NOT LIABLE FOR ANY DAMAGE RESULTING FROM INSTALLATION BY UNSKILLED PERSONNEL. ANY SYSTEM DAMAGE CAUSED BY A WRONG INSTALLATION AND/OR CONNECTION AUTOMATICALLY VOIDS THE WARRANTY.**

⚠ **WARNING! DO NOT CONNECT HYDRAULIC UNITS OTHER THAN THE SPECIFIED ONES (SEE ARAG GENERAL CATALOG). ARAG SHALL NOT BE LIABLE FOR DAMAGE TO THE PRODUCT, MALFUNCTIONS AND RISKS OF ANY KIND CAUSED BY THESE WHEN THE MODULE IS CONNECTED TO NON-ORIGINAL UNITS OR UNITS NOT SUPPLIED BY ARAG.**

**6 WIRING CONNECTIONS**



**CAUTION:**

To avoid short circuits, do not connect the power cables to battery before the installation is completed. Before powering up the computer, make sure the tractor battery voltage is as specified (12 VDC).

- Use only the cables provided with the ARAG computers.
- Take care not to break, pull, tear or cut the cables.
- Use of unsuitable cables not provided by ARAG automatically voids the warranty.
- ARAG is not liable for any damage to the equipment, persons or animals caused by failure to observe the above instructions.



Use **ONLY** the cables and accessories indicated in the catalog, having technical features suitable for the use to be made of them.

**6.1 General precautions for a correct harness position**

**• Securing the cables:**

- secure the harness so that it does not interfere with moving parts;
- route the harnesses so that they cannot be damaged or broken by machine movements or twisting.

**• Routing the cables to protect against water infiltrations:**

- the cable branches must ALWAYS be facing down (Fig. 5).

**• Fitting the cables to the connection points:**

- do not force the connectors by pushing too hard or bending them: the contacts may be damaged and computer operation may be compromised.

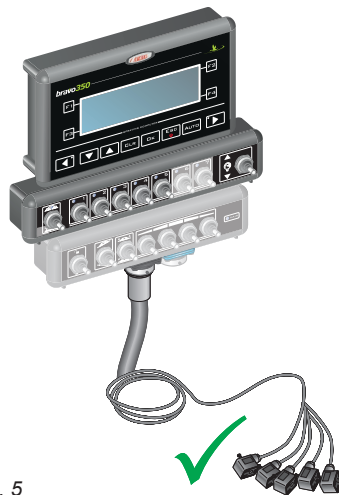

Fig. 5



Fig. 6

**6.2 Power supply connection**

Connect the multicore connector to the monitor, check it is correctly connected, and turn the ring nut clockwise until connector blocking.

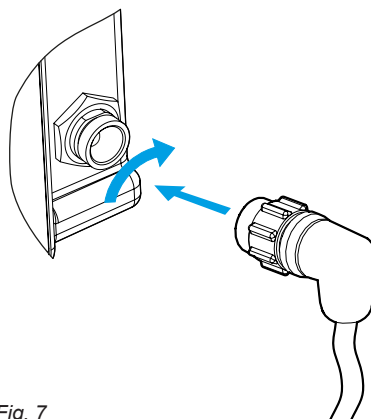

Fig. 7

## 6.3 Connection of multicore connector

Connect the multicore connector to the monitor (connections **4** and **5**, "Fig. 3" on page 6); check it is correctly connected, and turn the ring nut clockwise until connector blocking.

## 6.4 Control unit valve connection

- ⚠ **Use ARAG valves: use of unsuitable valves not provided by ARAG automatically voids the warranty. ARAG is not liable for damage to the equipment, people, animals or property caused by failure to observe the above instructions.**
- All valve connectors must be provided with seals before being connected (Fig. 8).
- Make sure the seals are correctly fitted to avoid water infiltration when using the control unit.

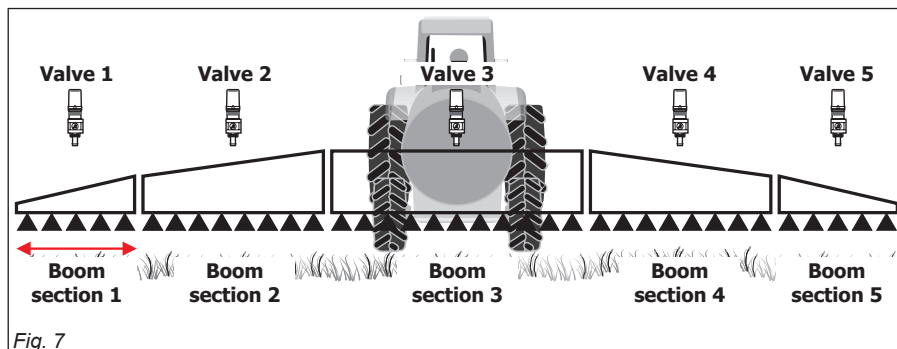

Connector 1 shall control the valve that in turn is connected to the boom section 1, and so on with the other valves.

Connect "connector 1" to "valve 1", and then the other connectors with increasing numbers from left to right: the boom section 1 is the furthest from the machine on the left, looking at the machine from the rear side (Fig. 7). The Fig. 7 is an example with 5-way Bravo 350 unit with 5 sections.

Fix the connectors to the relevant valves according to the indicated initials.

- Remove the protective cap (1) from the valve.
- Place seal (2) onto connector (3) and push the connector fully home (4): be careful not to bend the electric contacts upon insertion on the valve.
- Tighten screw (5) fully home.

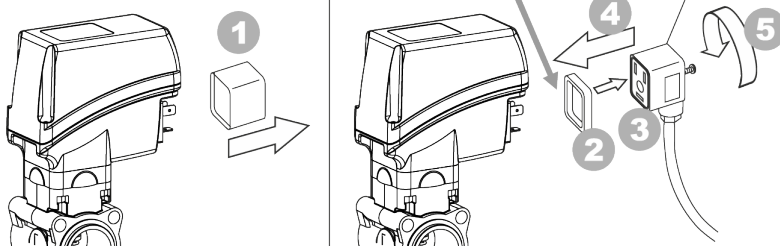

### • CONTROL UNIT

LABEL	CONNECTION
<b>G</b>	Main valve
<b>P</b>	Control valve

### • SECTION VALVE UNIT

LABEL	CONNECTION
<b>1</b>	Section valve no.1
<b>2</b>	Section valve no.2
<b>3</b>	Section valve no.3
<b>4</b>	Section valve no.4
<b>5</b>	Section valve no.5
<b>6</b>	Section valve no.6
<b>7</b>	Section valve no.7

In case there are more monitor switches than section valves, connect the cables as indicated in the table below.

No. of section valves	Switches to be used	Cables to be connected to the valves
<b>2</b>	2 - 4	1 - 2
<b>3</b>	2 - 3 - 4	1 - 2 - 3
<b>4</b>	1 - 2 - 4 - 5	1 - 2 - 3 - 4
<b>5</b>	1 - 2 - 3 - 4 - 5	1 - 2 - 3 - 4 - 5
<b>6</b>	1 - 2 - 3 - 4 - 5 - 6	1 - 2 - 3 - 4 - 5 - 6
<b>7</b>	1 - 2 - 3 - 4 - 5 - 6 - 7	1 - 2 - 3 - 4 - 5 - 6 - 7



6.5 Hydraulic valve connection

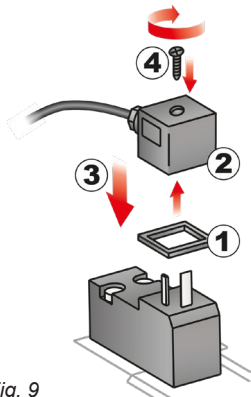

Bravo 350 can control up to 7 hydraulic functions through double action valves.

Fix the connectors to the relevant valves according to the initials indicated in your assembly general diagram ("5 System recommended composition" on page 5).

- Position seal (1) onto connector (2), then connect the latter pressing it fully home (3): **during this operation, take special care not to bend valve electric contacts.**
- Insert screw inside connector, and screw it (4) until it is tightened.

The function of each switch on the hydraulic function control panel is described below.

Fig. 9

- Connect the connector marked with "DD" to the pilot valve, and then the other connectors, as specified on the table:

CONTROL	MOVEMENT	CONNECTOR
<p>Section movement 1 - 2 - 3 - 4</p>	Opening	1 ÷ 4 A
	Closing	1 ÷ 4 C
<p>Boom height</p>	Opening	AA
	Closing	AC
<p>Boom lock</p>	Opening	BA
	Closing	BC
<p>Boom leveling</p>	Opening	CA
	Closing	CC

6.6 Connection of sensors and available functions

Harness cables are marked with a symbol denoting their functions: please see the table for correct harness connection.

**Use ARAG sensors: use of unsuitable sensors not provided by ARAG automatically voids the warranty. ARAG is not liable for damage to the equipment, persons or animals caused by failure to observe the above instructions.**

ARAG sensors feature the Tyco Superseal® connector. Insert connector fully home, until hearing a click of the retaining tab. The single products are supplied with the sensor connecting instructions.



Fig. 10



Fig. 11

LABEL	CONNECTION
<b>F</b>	Flowmeter
<b>S</b>	Speed sensor
<b>M</b>	Pressure sensor
<b>T</b>	Filling flowmeter <b>or</b> Level sensor
<b>R</b>	Foam marker
<b>X</b>	RPM sensor

6.7 Power supply connection

The package includes the power connector (component 3, Fig. 1) to be connected to the farming machine battery; Fig. 14 shows the drilling template of the power connector. Connect the power connector to the battery wires using two 6-mm faston connectors, as indicated in Fig. 12 and Fig. 13. Use the cable provided with the package (component 2, Fig. 1) to connect the computer to the power supply.

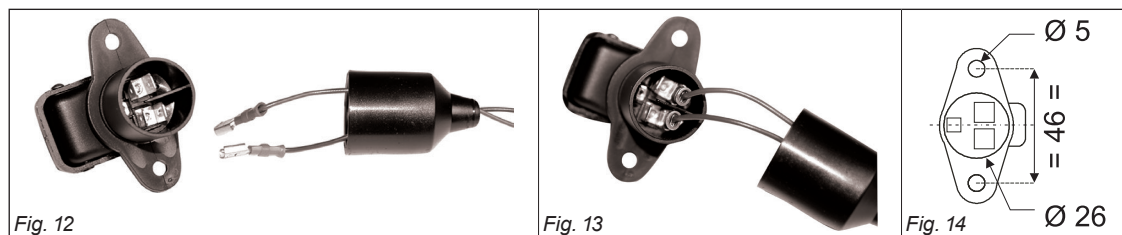

Fig. 12

Fig. 13

Fig. 14

**CAUTION:** To avoid short circuits, do not connect the power cables to battery before the installation is completed. Before powering up the computer and control unit, make sure the battery voltage is as specified (12 Vdc).

BRAVO 350 is supplied directly by the farming machine battery (12 Vdc): ALWAYS switch on the computer through the monitor, and then remember to switch it off using the specific key on the control panel.

**If BRAVO 350 remains on for a long time with machine off, the tractor battery could run flat: in case of prolonged breaks of the machine with engine off, make sure the computer is off, too.**

The power source must be connected as indicated in Fig. 15: the computer must be directly connected to the farming machine battery. **DO NOT** connect the computer to key-operated switch (15/54).

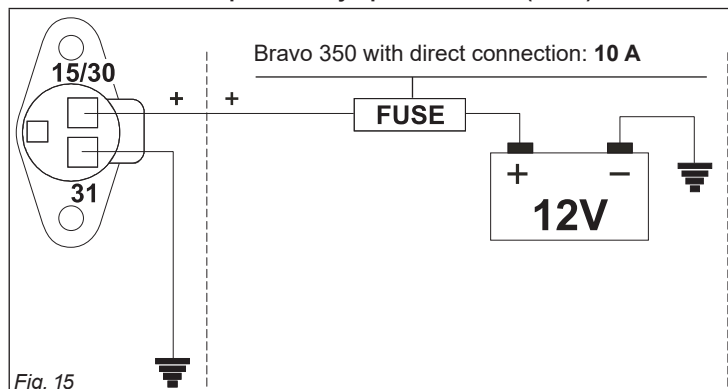

Fig. 15

**CAUTION:**

- The power circuit shall ALWAYS be protected by a fuse like the ones for automotive applications: 10 Amperes.
- All cables connected to the battery shall have a minimum cross-section of 2.5 sq. mm.

To avoid short-circuits, connect the power cable connector only after completing installation.

- Use cables with suitable terminals ensuring correct connection of all wires.

## 7 SETTING

### 7.1 Tests and checks before setting

Before computer setting, check:

- ⚠ • that all components are correctly installed (control unit and sensors);
- the correct connection to the power source;
- the component connection (main control unit and sensors).

Failure to correctly connect system components or to use specified components might damage the device or its components.

### 7.2 Computer switching on/off

#### • Ordinary switching on

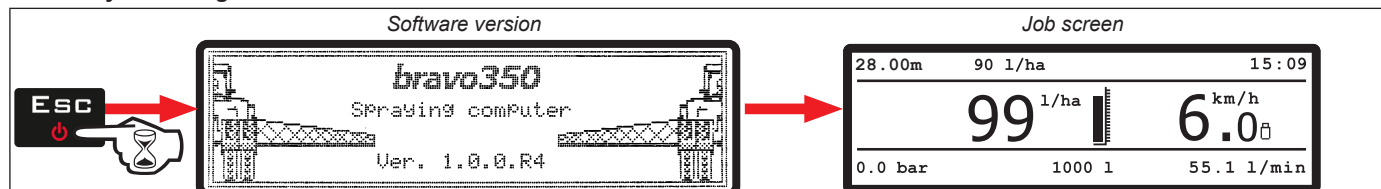

Fig. 16

Keep key **ESC** pressed until switching on the display: after the software version, BRAVO 350 displays the job screen (Fig. 16).

#### • Switching on to activate the advanced setup

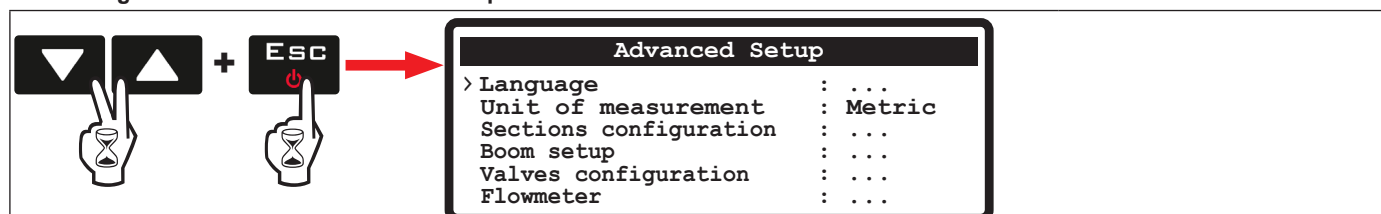

Fig. 17

Contemporaneously press the key sequence until switching on the Bravo. Release key **ESC** keeping pressed the arrow keys until the display shows the menu **Advanced setup** (Fig. 17).

#### • Switching off



Fig. 18

Keep key **ESC** pressed until the display shows the message **WAIT: saving data**.

Release the key and wait for the saving process to complete (Fig. 18); after a few seconds the computer turns off.

**During switching off do NOT press any other key and do NOT disconnect the power supply until BRAVO 350 turns off.**  
**WARNING: ALWAYS use the special key to switch off the computer; otherwise ALL data concerning the spraying and the programming will be lost.**

## 7.3 Use of keys for setting

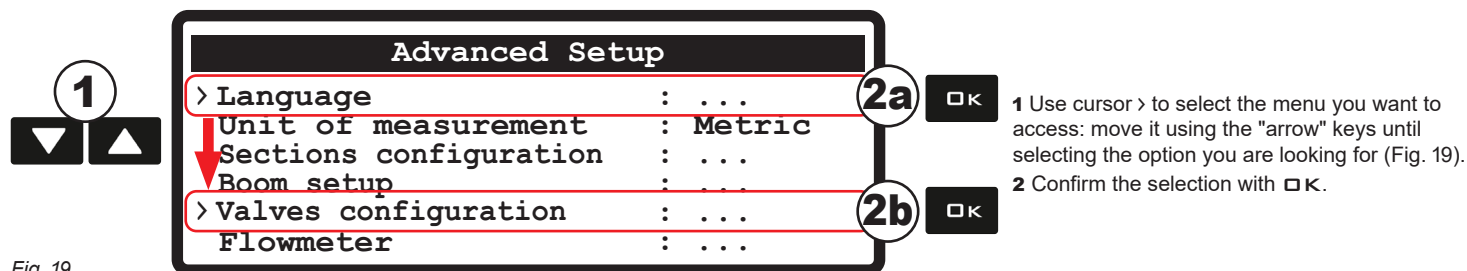

Fig. 19

## DATA SELECTION

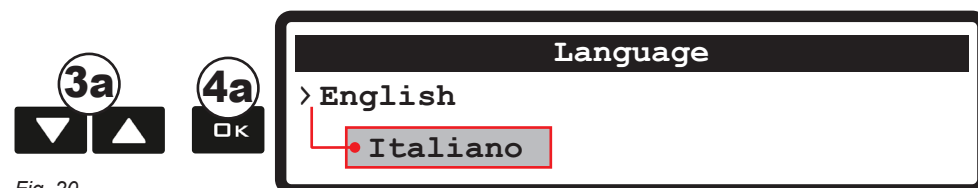

Fig. 20

When it is about a simple selection of data, BRAVO 350 displays the active value (2a, Fig. 19).

**3a** Press the arrow keys one after the other to select another item; the display will show the selected item.

**4a** Confirm with **OK**.

*Item quick scrolling: keep one of the arrow keys pressed.*

*Exit without confirming the change: press **ESC**.*

## ACCESS TO A SUBMENU

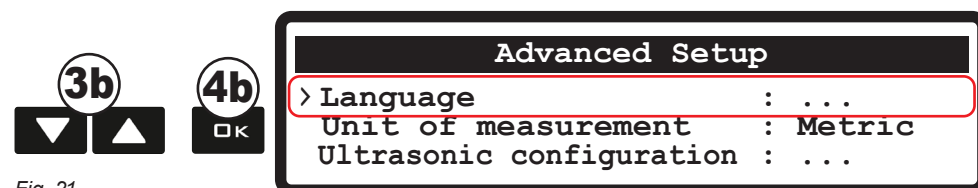

Fig. 21

In case of a submenu BRAVO 350 displays three dots". . ." (2b, Fig. 21).

**3b** Press the arrow keys in succession to move across the menu items. The cursor > will move on the selected one.

**4b** Press **OK** to access the submenu.

*Item quick scrolling: keep one of the arrow keys pressed.*

*Exit without confirming the change: press **ESC**.*

## ENABLE / DISABLE

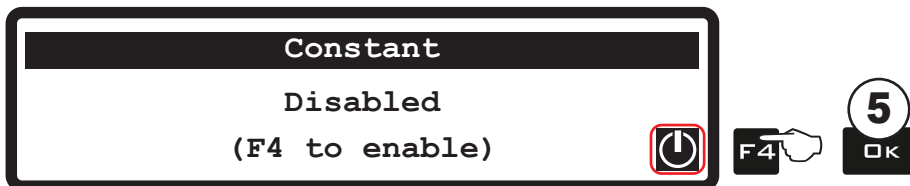

Fig. 22

Some submenu items require enabling before configuration.

Within the submenu, press the **F4** key when the symbol Fig. 22 is displayed.

Depending on the current status, (enabled/disabled) pressing the key allows switching between the two statuses.

**5** Press **OK** to confirm.

Exit without confirming the change: press **ESC**.

## ENTERING A NUMERICAL VALUE

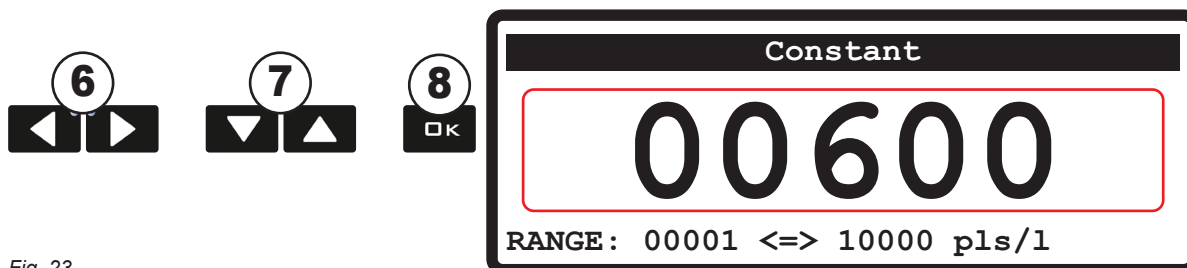

Fig. 23

**6** Press the arrow keys to move through numerical value digits.

**7** Press the arrow keys in succession to change the value.

To reset the data press **CLR**.

**8** Press **OK** to confirm the data.

Quick increase/decrease of the value: keep one of the arrow keys pressed.

Exit without confirming the change: press **ESC**.

**8 ADVANCED SETUP**



This operation must be done once only, when installing the computer.

**ACCESS TO ADVANCED SETUP (WITH COMPUTER OFF)**

- Press the key sequence simultaneously until switching Bravo 350 on.
- Release the key **ESC** by keeping the arrow keys pressed until the menu is displayed

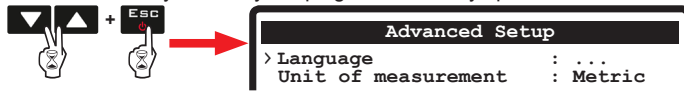

For a correct use of the keys during setting, refer to Par. 7.3.

	Menu	Default	Min	Max	Other values that can be set / Notes
	<b>Language</b>	English	---	---	Italiano - English - Español - Português - Français - Deutsch - Ελληνικά - Cesky - Hrvatski - Magyar - 日本語 - Lietuvių - Polski - Русский
	<b>Unit of measurement</b>	Metric (l/h, km/h, bar)	---	---	US (GPA, mil/h, PSI)
<b>Par. 8.1</b>	<b>Sections configuration</b>				
	Sections number	5/7	1	7	1 / 2 / 3 / 4 / 5 / 6
<b>Par. 8.2</b>	<b>Boom setup</b>				
	Nozzle number	40	1	1000	1 ÷ 1000
	Section 1 ÷ Section 7	---	---	---	
	Section	4.00 m 13.12 ft	0.00 m 0.00 ft	100.00 m 330.00 ft	0.00 ÷ 100.00 m 0.00 ft ÷ 330.00 ft
<b>Par. 8.3</b>	<b>Valves configuration</b>				
	Master	3 ways	---	---	2 ways - None
	Pressure regulator	3 ways	---	---	2 ways
	Section	3 ways	---	---	2 ways
	Automatic switch-off	No (P mode)	---	---	Yes (M mode)
<b>Par. 8.4</b>	<b>Flowmeter</b>				
	Type	Orion 4621XA3XXXX	---	---	See "Tab. A" on page 18
	Min. flowrate alarm	5.0 l/min 1.32 GPM	0.1 l/min 0.01 GPM	1000.0 l/min 270.00 GPM	Disabled
	Max. flowrate alarm	100.0 l/min 26.42 GPM	0.1 l/min 0.01 GPM	1000.0 l/min 270.00 GPM	Disabled
	Constant	600 pls/l 2271 pls/gal	1 pls/l 1 pls/gal	10000 pls/l 38000 pls/gal	---
<b>Par. 8.5</b>	<b>Pressure sensor</b>				
	Type	Disabled	---	---	ARAG 466113.200 - ARAG 466113.500 - Other...
	Maximum pressure	---	0.1 bar 1 psi	150.0 bar 2200 psi	Item active only if a sensor is selected
<b>Par. 8.6</b>	<b>Flowrate calculation sensor</b>	Flowmeter	---	---	Pressure - Both
<b>Par. 8.7</b>	<b>Tank level</b>				
<b>Par. 8.7.1</b>	Mode	---	---	---	SELECTED MODE: MANUAL
	Capacity	2000 l 528 gal	1l 0.1 gal	10000 l 2700.0 gal	---
	Minimum level alarm	150 l 40 gal	1l 0.1 gal	10000 l 2700.0 gal	---
<b>Par. 8.7.2</b>	Mode	---	---	---	SELECTED MODE: LEVEL SENSOR
	Capacity	1000 l 246 gal	---	---	---
	Minimum level alarm	150 l 40 gal	1l 0.1 gal	10000 l 2700.0 gal	---
	Calibration	...	---	---	See "8.7.2 Tank level - Level sensor mode" on page 19
	Zero calibration	4.000 mA	---	---	---
	Load/Save calibr.	...	---	---	---
<b>Par. 8.7.3</b>	Mode	---	---	---	SELECTED MODE: FILLING FLOWMETER
	Capacity	2000 l 528 gal	1l 0.1 gal	10000 l 2700.0 gal	---
	Minimum level alarm	150 l 40 gal	1l 0.1 gal	10000 l 2700.0 gal	---
	Type	Orion 462XXA4XXXX	---	---	See "Tab. C" on page 20
	Constant	300 pls/l 1136 pls/gal	1 pls/l 1 pls/gal	10000 pls/l 37000 pls/gal	---
	Minimum flowrate	10.0 l/min 2.64 GPM	---	---	See "Tab. C" on page 20
	Maximum flowrate	200.0 l/min 52.83 GPM	---	---	See "Tab. C" on page 20

**CLR** Fast data reset



Scroll menu items or Increase/decrease data



Confirm menu access or data change



Exit menu or data change



Par. 7.3

Par. 8.8	<b>Revolutions counter</b>				
	Constant	Disabled	1 pls/rev	10000 pls/rev	---
	Minimum speed alarm	Disabled	1 rpm	10000 rpm	Items only visible if the constant is activated
	Maximum speed alarm	Disabled	1 rpm	10000 rpm	
Par. 8.9	<b>Foam marker</b>	Manual	---	---	Semi-autom. - Automatic
Par. 8.10	<b>External device</b>	None	---	---	Serial LOG - B400S / D80 - IBX20
Par. 8.11	<b>Access level</b>	Technician	---	---	Operator - Manager - ARAGTech

8.1 Sections configuration

Set the number of installed section valves (1 ÷ 7).

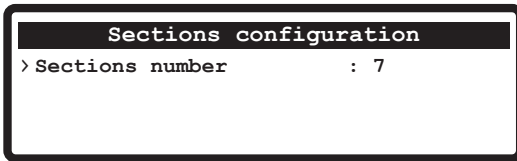
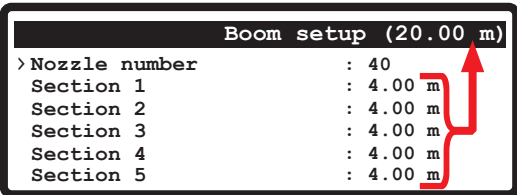

Fig. 24

8.2 Boom setup

Set the width of the single boom sections and the total nozzle number.



**Nozzle number:**  
 enter the number of boom nozzles.  
 Bravo 350 distances the boom nozzles equally: this is to favor systems with nozzles at a distance other than the standard value of 50 cm (e.g. 25 cm).  
**This does not affect the width of the single section and of the boom.**

**Set the width of each section:**  
 Bravo 350 adds up the entered values and shows the total width.

Fig. 24

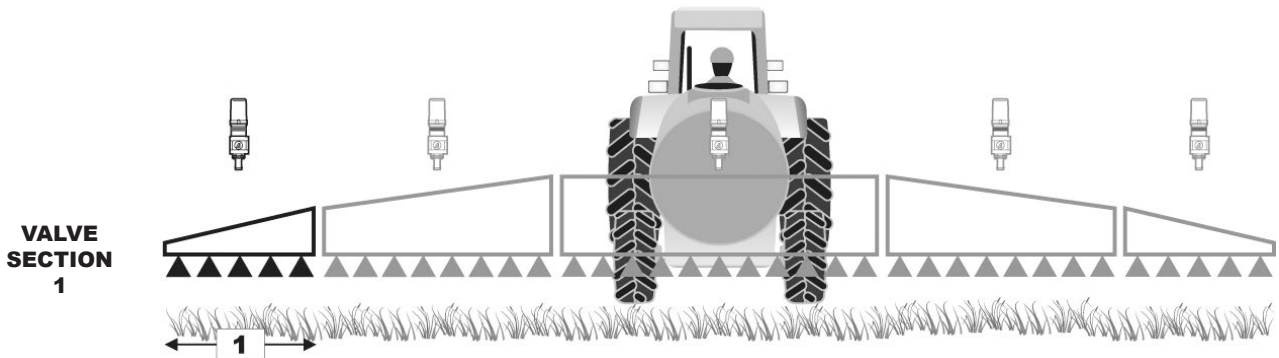

Fig. 25

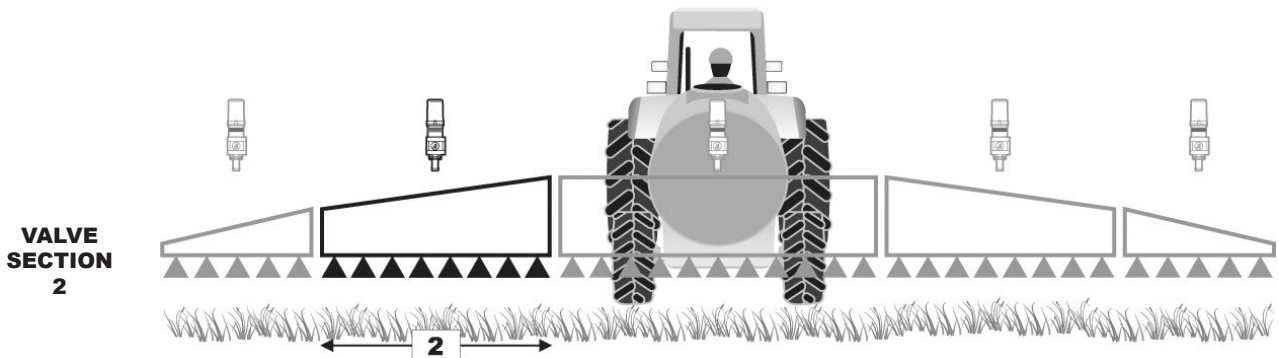

Fig. 26

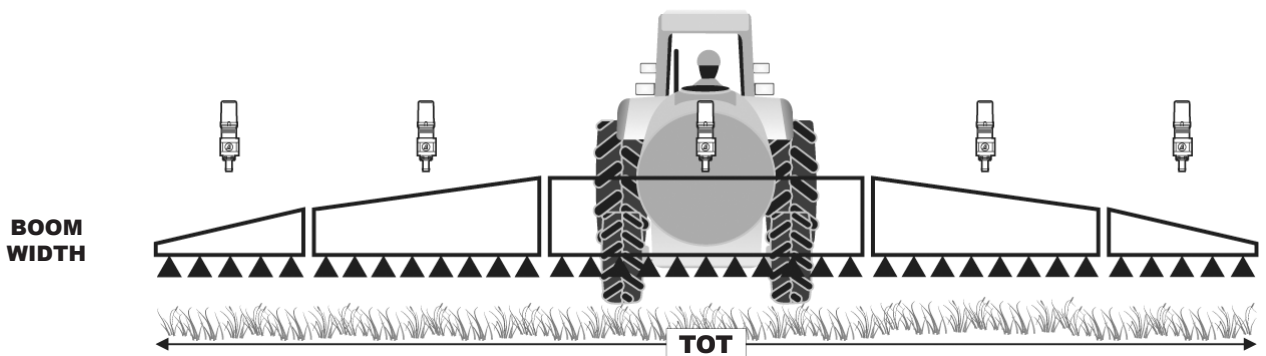

Fig. 27

**CLR** Fast data reset

Scroll menu items or Increase/decrease data

**OK** Confirm menu access or data change

**ESC** Exit menu or data change



8.3 Valves configuration

Set the type of valves installed on the system and the relevant data.

> **Master:** indicate the type of installed main control valve.

- 2 ways: drain valve
- 3 ways: main valve
- None

> **Pressure regulator:** indicate the type of installed control valve.

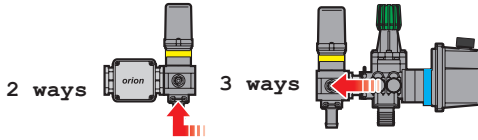

> **Section:** indicate the type of installed motorized section valves.

- 2 ways: valves without metered by-passes
- 3 ways: valves with metered by-passes

> **Automatic switch-off**

Indicate the section valve operation mode. especially if the section automatic switch-off is active when the main control valve is closed.

- Yes (M mode)
- No (P mode)



**It is compulsory to set the M mode (option Yes) when None main valve is present in the system.**

• **"M" operation mode (option Yes):**

The section valves are closed or opened by acting on the main switch, provided that the switch relating to section valves is properly positioned:

- if the switches of sections are set to OFF (lever down), sections will not be controlled by acting on the main switch.
- If one or more section valve switches are set to ON (lever up), opening or closing the main switch opens or closes the section valves as well.

• **"P" operation mode (option No):**

The section valves are controlled independently.

Main switch control functions do not affect section valve opening or closing.

Default setting.



8.4 Flowmeter

Set the installed flowmeter and the relevant data. Tab. A contains the values that will be automatically set by selecting the flowmeter code. Nevertheless these data can be modified.

> **Type**: indicate the type of installed flowmeter (Tab. A).

> **Min. flowrate alarm**

> **Max. flowrate alarm**

The flowrate alarms (minimum or maximum) activate when, during the spraying, the flowmeter rate does not respect the set limits.



For the procedure to be followed in case of alarms, please refer to Par. 11.2 Operation errors.

> **Constant**: indicate the constant of the installed flowmeter.

ORION FLOWMETERS

TYPE	METRIC UNITS OF MEASUREMENT - METR. l/100 m			US UNIT OF MEASUREMENT		
	Constant (pls/l)	Min. flowrate (l/min)	Max. flowrate (l/min)	Constant (pls/gal)	GPM min. flowrate	GPM max. flowrate
Orion 4621xA0xxxx	6000	0.5	10.0	22710	0.13	2.64
Orion 4621xA1xxxx	3000	1.0	20.0	11355	0.26	5.28
Orion 4621xA2xxxx	1200	2.5	50.0	4542	0.66	13.21
Orion 4621xA3xxxx	600	5.0	100.0	2271	1.32	26.42
Orion 462xxA4xxxx	300	10.0	200.0	1136	2.64	52.83
Orion 4622xA5xxxx	150	20.0	400.0	568	5.28	105.67
Orion 4622xA6xxxx	100	30.0	600.0	378	7.93	158.50
Orion 4622xA7xxxx	75	40.0	800.0	284	10.57	211.34



The default values can be modified.

WOLF FLOWMETERS

TYPE	METRIC UNITS OF MEASUREMENT - METR. l/100 m			US UNIT OF MEASUREMENT		
	Constant (pls/l)	Min. flowrate (l/min)	Max. flowrate (l/min)	Constant (pls/gal)	GPM min. flowrate	GPM max. flowrate
Wolf 462x2xxx	1015	2.5	50.0	3842	0.66	13.21
Wolf 462x3xxx	625	5.0	100.0	2366	1.32	26.42
Wolf 462x4xxx	250	10.0	200.0	946	2.64	52.83
Wolf 462x5xxx	132	20.0	400.0	500	5.28	105.67
Wolf 462x7xxx	60	40.0	800.0	227	10.57	211.34



The default values can be modified.

Tab. A	Other...	625	10.0	200.0	2366	2.64	52.83
--------	----------	-----	------	-------	------	------	-------

8.5 Pressure sensor

The pressure sensor is used to detect the pressure in the system and, depending on the case, for various other functions.

• **Flowmeter enabled** (Par. 8.6 Flowrate calculation sensor > Both): displays the job pressure when the machine works within the flowmeter limits. When the flowmeter operates outside the limits the measured pressure is used to calculate the spray rate.

• **Flowmeter disabled** (Par. 8.6 Flowrate calculation sensor > Pressure): the pressure sensor is always used to calculate the application rate

Set the type of installed pressure sensor and the relevant full scale.

> **Type**: indicate the type of installed sensor (available models indicated in Tab. B).

> **Maximum pressure**

Indicate the full scale of the pressure sensor installed on the system.



When the option Disabled (Default) is active, the item Maximum pressure is no longer displayed.

The table below indicates the values that are automatically set selecting the sensor code:

ARAG PRESSURE SENSOR

TYPE	Max pressure	
	bar	PSI
ARAG 466113.200	20.0	290
ARAG 466113.500	50.0	725



The default values can NOT be modified.

Tab. B	Other...	50.0	725
--------	----------	------	-----

8.6 Flowrate calculation sensor

Set the type of sensor to be used to calculate the flowrate:

> **Flowmeter**

The Flowmeter is the only sensor used to read the flowrate.

> **Pressure**

The Pressure sensor is the only sensor used to read the flowrate.

Set nozzles par. 9.4

> **Both**

Within the working limits, the computer uses the flowmeter, otherwise it uses the pressure sensor (ONLY if properly configured).

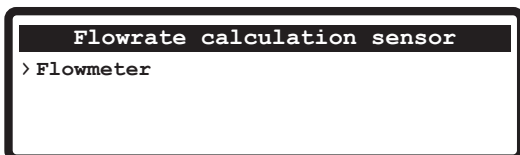

Fig. 25

8.7 Tank level

First of all configure the submenu **Mode** and the selected option data.  
 The tank filling will be managed in different ways according to the preset mode.  
 Possible options:  
 > **Manual**: par. 8.7.1  
 > **Level Sensor**: par. 8.7.2  
 > **Filling flowmeter**: par. 8.7.3

8.7.1 Tank level - Manual Mode

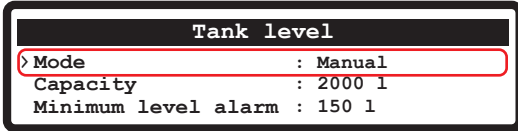

Fig. 26

> **Capacity**: indicate the rated capacity.  
 > **Minimum level alarm**: indicate the range value.  
 The tank alarm activates when during the treatment the tank level falls below the set value (Par. 10.5 Display).

8.7.2 Tank level - Level sensor mode

The level sensor installed in the system allows displaying the tank level in real time (Par. 10.5 Display).

**This mode operates correctly ONLY if the level sensor has been calibrated, or if the calibration of a similar tank has been loaded from USB pendrive.**

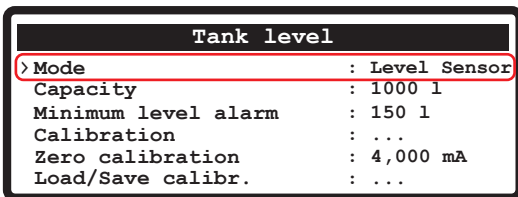

Fig. 27

> **Capacity**: the computer displays the tank capacity calculated after the calibration.  
 > **Minimum level alarm**: indicate the range value.  
 The tank alarm activates when during the treatment the tank level falls below the set value (Par. 10.5 Display).  
 > **Calibration**: enters the calibration procedure of the level sensor.

**The level sensor calibration is ONLY possible if the system is provided with a flowmeter.**  
 Before starting the procedure carry out the following operations:



Fig. 28

- 1** Make sure the main switch is in position OFF (Fig. 28).
- 2** Fill the tank with clean water WITHOUT ADDING CHEMICAL SUBSTANCES. The tank must be full. Visually check the reached level.

- 3** From the job screen check that the manual mode is active (the display shows **Man. Reg.** ). Otherwise activate it by pressing **AUTO** (Par. 10.7.2).
- 4** Adjust the output keeping the switch of the control valve (Fig. 28) pressed upwards, **being careful not to exceed the maximum flowrate of the selected flowmeter.**
- 5** Switch the computer off and on again in advanced setup mode ("Advanced setup" on page 14).



Fig. 29

**6** Enter the **Tank level** menu, activate the **Level sensor mode**(Fig. 27) and select the **Calibration** item.  
 BRAVO 350 requests to enter the estimated tank capacity (Fig. 29): enter the value.

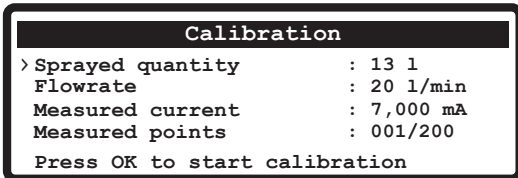

Fig. 30

- 7** Immediately afterwards the computer passes to the calibration start screen (Fig. 30): the message **Press OK to start calibration** blinks on the display.
- 8** Press **OK**: calibration starts.  
 The message **Enable spraying command!** blinks on the display.
- 9** Start the spraying system: open, in succession, all section valves and the main control (Fig. 28, switches in position **ON**).

**10** The display will show in real time the quantity of sprayed water and the calibration status. The message **CALIBRATION: [OK] to save/ [ESC] to exit** blinks on the display.  
**In order to close the calibration curve the value of the level sensor must be between 3.0 mA and 5mA; press OK to manually stop the calibration (AND SAVE IT) OR PRESS ESC TO STOP WITHOUT SAVING IT.**

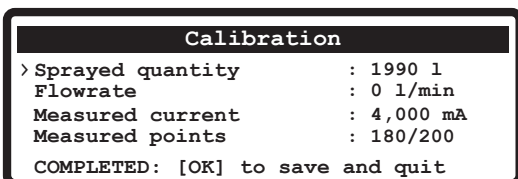

Fig. 31

**11** If the calibration has not been manually ended, when the flowrate value reaches zero (Fig. 31) and remains so for at least 10 s, BRAVO 350 automatically finishes the procedure and displays the message **COMPLETED: OK to save and quit.**  
 Press **OK**: the calibration is complete.

**After having completed the calibration and checked the sensor correct operation, we recommend to memorize the calibration on USB pendrive.**

> **Zero calibration:** it accesses the "zero" calibration of the level sensor.

The level sensor zero must be calibrated when:

- the presence of fluid inside the tank is displayed, even when it is empty.
- a calibration curve already made with the same tank by means of another Arag computer is loaded. **The tank must be empty.**

Press **OK** to reset the sensor residual signal.

The value read by the level sensor must be within 3.0 mA and 5mA.

> **Load/Save calibr.:** the level sensor calibration can be loaded or saved on USB pendrive to reconfigure the device if necessary, solve problems, or configure another BRAVO 350 without having to repeat all operations.

**After having completed the calibration and checked the sensor correct operation, we recommend to memorize the calibration on USB pendrive.**

Before any other operation, insert the USB pendrive in its slot.

> **Load tank profile from USB:** select this option and press **OK**.

The confirmation message **Successfully completed! (TANK.TKL)** is displayed once the configuration process is completed. Press **ESC**.

> **Save tank profile to USB:** select this option and press **OK**.

The confirmation message **Successfully completed! (TANK.TKL)** is displayed once the saving process is completed. Press **ESC**.

8.7.3 Tank level - Filling flowmeter mode

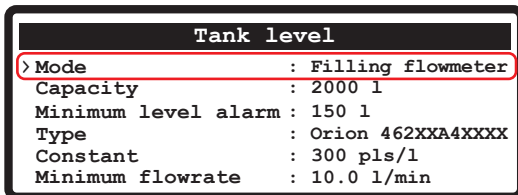

Fig. 32

The filling flowmeter installed in the system allows displaying the tank filling data in real time.

> **Capacity:** indicate the rated capacity.

> **Minimum level alarm:** indicate the range value.

> **Type:** indicate the filling flowmeter installed and the relevant data.

Tab. C contains the values that will be automatically set by selecting the flowmeter code. Nevertheless the constant can be modified.

> **Constant:** indicate the constant of the installed filling flowmeter.

ORION FLOWMETERS

TYPE	METRIC UNITS OF MEASUREMENT - METR. l/100 m			US UNIT OF MEASUREMENT		
	Constant (pls/l)	Min. flowrate (l/min)	Max. flowrate (l/min)	Constant (pls/gal)	GPM min. flowrate	GPM max. flowrate
Orion 462xxA4xxxx	300	10.0	200.0	1136	2.64	52.83
Orion 4622xA5xxxx	150	20.0	400.0	568	5.28	105.67
Orion 4622xA6xxxx	100	30.0	600.0	378	7.93	158.50
Orion 4622xA7xxxx	75	40.0	800.0	284	10.57	211.34



The default values can be modified.

WOLF FLOWMETERS

TYPE	METRIC UNITS OF MEASUREMENT - METR. l/100 m			US UNIT OF MEASUREMENT		
	Constant (pls/l)	Min. flowrate (l/min)	Max. flowrate (l/min)	Constant (pls/gal)	GPM min. flowrate	GPM max. flowrate
Wolf 462x4xxx	250	10.0	200.0	946	2.64	52.83
Wolf 462x5xxx	132	20.0	400.0	500	5.28	105.67
Wolf 462x7xxx	60	40.0	800.0	227	10.57	211.34



The default values can be modified.

Other . . .	625	10.0	200.0	2366	2.64	52.83
-------------	-----	------	-------	------	------	-------

Tab. C

CONTINUES



8.8 Revolutions counter

Set the data of the RPM sensor (if installed in the system).  
The sensor is **Disabled** by default.

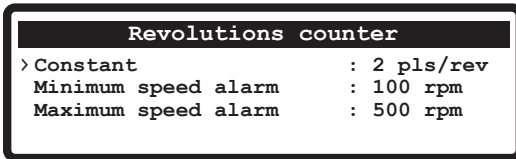

Fig. 33

Activate the RPM sensor by pressing **F4** (page 13) and indicate the **Constant**.  
The display shows the editable items related to alarms:

- > **Minimum speed alarm**
- > **Maximum speed alarm**

Activate the alarms by pressing **F4** (page 13) and indicate the values.  
The speed alarms (minimum or maximum) activate when the measured RPM exceed the set limits.

**The control is active only when the spraying is active (main switch ON).**



**If the RPM sensor is not installed, select Disabled in the Constant menu. If the constant is enabled press F4 (page 13) to disable it. The Minimum speed alarm and Maximum speed alarm (Fig. 33) items will no longer be displayed**

8.9 Foam Marker

Set foam marker operating mode.  
The foam marker is set to **Manual** mode by default.



Fig. 34

> **Manual**

The foam marker is controlled through the special keys (par. 10.2 on page 38)

> **Semi-autom.**

Main switch ON --> foam marker ON  
Main switch OFF --> foam marker OFF

**The special keys enable the desired side (par. 10.2 on page 38)**

> **Automatic**

Main switch ON --> foam marker ON  
Main switch OFF --> foam marker OFF

**Whenever the foam marker is ON, the active side automatically changes.**

The foam marker keys are equipped with a red LED that turns steady on during the treatment, indicating the correct operation of the relevant foam marker.

The red LED flashing during treatment in **Semi-autom.** or **Automatic** mode may indicate one of the following conditions:

- The main switch is set to OFF and the section switches are set to ON.
- The main switch is set to ON and the section switches are set to OFF.
- The main switch and the section switches are set to OFF.

These situations prevent the foam marker from working properly.

8.10 External device

Enable / disable any connection to an external device.  
The **None** item is enabled by default.

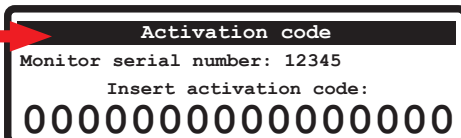
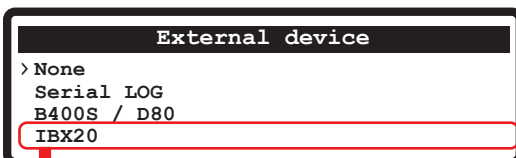

Fig. 35

> **None**

> **Serial LOG**

It returns a string of work-related data on the serial port (par. 9.14 on page 36) to be sent by cable or transmission to an equipment being used.

> **B400S / D80**

It allows Bravo 350 to:

- receive the treatment data of the variable application rate from a connected device
- receive the speed data from a connected device. The speed source must be set as **GPS** (9.8 on page 30).
- to manage the automatic closing/opening of the sections and the main valve via the connected device.

This avoids overlapping already covered areas.

**Function only available in AUTO mode (par. 10.7.1 on page 40).**



**To connect Bravo 400S or Delta 80 to Bravo 350, please order the appropriate connection cable separately from the Arag general catalog and consult the relevant instructions.**

> **IBX20**

It allows connecting IBX20 to Bravo 350.

The connection allows:

- Automatically closing the sections (TC-SC)
- Using variable application rate (TC-GEO)
- Recording job's data (TC-BAS)
- Enabling/disabling the external general control via Auxiliary Function (AUX-N)
- Receiving the speed data from a connected device. It is needed to set the speed source as **Tractor wheel / Tractor radar**

**Request ARAG the activation code to enable the additional function, which can be purchased separately.**

- Enter the supplied code and confirm.

For specifications on the use of IBX20 refer to the relevant manual.

8.11 Access level

It allows setting the user access level and password.

> **Operator**

The operator can only view the following:

Job selection / Current Job data / Jobs setup / Tank / Totalizers / Test / User preferences / Data logger.

> **Manager**

The operator can only view the following:

Job selection / Current Job data / Jobs setup / Working parameters / Tank / Flowrate correct. factor / Totalizers / Test / User preferences / Data logger / Load/save setup.

You can set an access PIN code.

> **Technician**

It allows configuring all monitor parameters: you can set an access PIN.

> **ARAGTech**

Reserved to ARAG personnel.

**PIN ENTRY (Manager AND Technician USERS)**

- Select the user level for which you want to enter the PIN (symbol > Fig. 37) and press and hold the button ►.

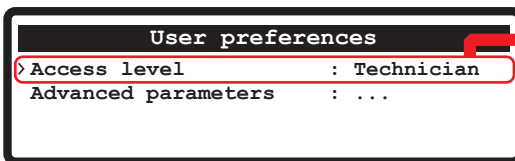

Fig. 36

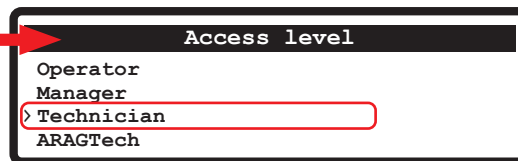

Fig. 37

The monitor displays the PIN entry page (Fig. 38):



Fig. 38



Fig. 39

- Enter the 5-digit PIN (Fig. 38).

Enter it again to confirm (Fig. 39).

- Press **OK** to enable the entered PIN. The display shows the message: **PIN code changed**

- Press **ESC** to stop the operation.

**PIN DELETION (Manager AND Technician USERS)**

- Select the user level for which you want to delete the PIN (symbol > Fig. 41) and press and hold the button ►.

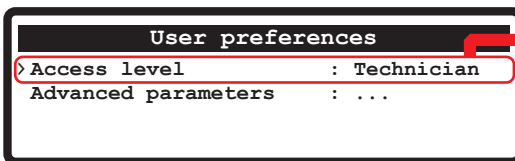

Fig. 40

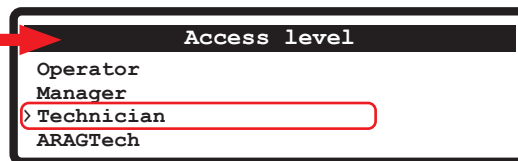

Fig. 41

The monitor displays the PIN entry page (Fig. 42):



Fig. 42

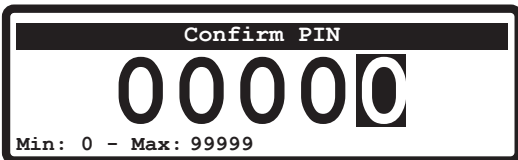

Fig. 43

- Enter 00000 as new PIN (Fig. 42).

- Enter 00000 again to confirm the deletion of the PIN code (Fig. 43).

- Press **OK** to complete the PIN deletion operation. The display shows the message: **PIN code changed**

- Press **ESC** to stop the operation.

8.12 Setup check after Advanced setup end

This screen is displayed only in case of errors when exiting the **Advanced setup**:

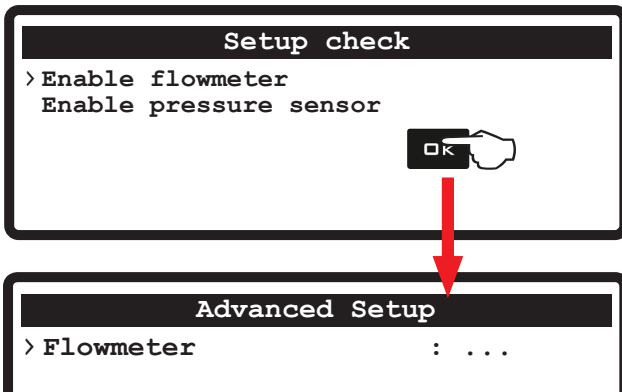



Fig. 44

In case of more error messages, select the message and press **OK**. BRAVO 350 automatically switches to the **Advanced Setup** and directly positions on the value to be modified.

Lower the display shows the mismatching data.

PAR.	ERROR MESSAGE	SET VALUES
 Par. 8.6 Par. 8.4	> Enable flowmeter The setting for the rate calculation requires the flowmeter, which is disabled though.	Flowrate calculation sensor: > Flowmeter or > Both
 Par. 8.6 Par. 8.5	> Enable pressure sensor The setting for the rate calculation requires the pressure sensor, which is disabled though.	Flowrate calculation sensor: > Pressure or > Both

9 USER SETTING

**ACCESS TO USER SETTING (WITH COMPUTER ON)**

Keep the **OK** key pressed until the menu is displayed.

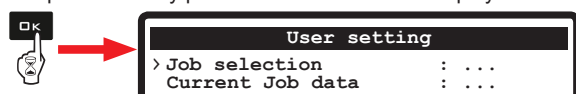

Fig. 45

For a correct use of the keys during setting, refer to Par. 7.3.

	Menu	Default	Min	Max	Other values that can be set / Notes
Par. 9.1	<b>Job selection</b>	---	---	---	See "9.1 Job selection" on page 26
Par. 9.2	<b>Current Job data</b>	Job's data (R01-0001.RPT)	---	---	---
Par. 9.3	<b>Jobs setup</b>	1	1	40	Jobs 2 ÷ 39 (See relevant table)
	Target rate	---	1 l/ha 0.1 GPA	10000 l/ha 1000.0 GPA	See relevant table
	Nozzle type	---	---	---	ISO005 ÷ ISO20 (See relevant table) User nozzles A ÷ J (See relevant table)
Par. 9.4	<b>Nozzles setup</b>				
	Flowrate	---	0.01 l/min 0.001 GPM	100.00 l/min 30,000 GPM	See relevant table
	Pressure	3.0 bar (ISO nozzles) 5.0 bar (User nozzles) 40 PSI (ISO nozzles) 73 PSI (User nozzles)	0.1 bar 1 PSI	100.0 bar 1450 PSI	---
	Minimum pressure alarm	Disabled	0.1 bar 1 PSI	100.0 bar 1450 PSI	0.1 bar ÷ 100.0 bar 1 PSI ÷ 1450 PSI
	Maximum pressure alarm	Disabled	0.1 bar 1 PSI	100.0 bar 1450 PSI	0.1 bar ÷ 100.0 bar 1 PSI ÷ 1450 PSI
Par. 9.5	<b>Working parameters</b>				
	Task Controller TC	...	---	---	---
	TC-BAS	Disabled	---	---	Enabled
	TC-SC	Disabled	---	---	Enabled
	TC-GEO	Disabled	---	---	Enabled
	Nozzles wear check	Disabled	1 %	50 %	1 ÷ 50 %
	Min. spraying speed	Disabled	0.1 km/h 0.0 MPH	100.0 km/h 65.0 MPH	0.1 ÷ 100.0 km/h 0.0 ÷ 65.0 MPH
	Regulation lock type	Disabled	---	---	Speed - Pressure
	Min. regulation speed	2.0 km/h 1.2 MPH	0.1 km/h 0.1 MPH	100.0 km/h 65.0 MPH	Regulation lock type: Speed
	Min. regulation pressure	1.0 bar 15 psi	0.1 bar 1 psi	100.0 bar 1450 psi	Regulation lock type: Pressure
Par. 9.5	<b>Rate controller</b>				
	Display cut-off (rate)	03.0 %	1.0%	99.9%	1.0% ÷ 99.9 %
	Regulation cut-off (rate)	01.5%	1.0%	99.9%	1.0% ÷ 99.9 %
Par. 9.7	<b>Tank</b>				
	Filling up	2000 l 528 gal	---	---	<b>ONLY WITH THE FOLLOWING MODE SELECTED: MANUAL / FILLING FLOWMETER (Par. 8.7)</b>
	Level	0 l 0 gal	0 l 0.0 gal	2000 l 528.3 gal	0 ÷ 2000 l 0.0 ÷ 528.3 gal
	Filled quantity	0 l 0 gal	---	---	---
	Estimated quantity need	----- l ----- gal	0.001 ha 0.001 ac	100.000 ha 100.000 ac	<b>ONLY WITH FILLING CALC. ENABLED (Par. 9.13.5)</b>
Par. 9.8	<b>Speed</b>				
	Source	Wheel sensor	---	---	GPS, Tractor wheel / Tractor radar
	Selected wheel type	1	1	3	2
	Wheels setting	...	---	---	---
	Constant calculation	Manual	---	---	Automatic
	Wheel constant 1 ÷ 3	50.00 cm/pls 19.68 in/pls	0.01 cm/pls 0.00 in/pls	150.00 cm/pls 59.06 in/pls	Wheel constant 1

CONTINUES



Par. 9.9	<b>Flowrate correct. factor</b>	1.00	0.01	10.00	---
Par. 9.10	<b>Press. sensor zero value</b>	---	---	---	---
Par. 9.11	<b>Totalizers</b>	Job's data (Txx-0001.RPT)	---	---	T02-0001.RPT ÷ T40-0001.RPT
Par. 9.12	<b>Test</b>				
	Speed simulation	No	---	---	Yes
	(S) Speed	---	---	---	---
	(F) Flow	---	---	---	---
	(T) Filling flowm.	---	---	---	Tank level sensor Items available only if the following is selected in the menu Advanced Setup > Tank level
	(X) Rev. counter	---	---	---	---
	(M) Pressure	---	---	---	---
	Battery voltage	---	---	---	---
	Display	...	---	---	---
	Keyboard & Switches	...	---	---	---
	GPS data	...	---	---	---
	Monitor serial number	XXXXXXXX	---	---	---
	Monitor hardware version	X.X.X	---	---	---
	Monitor software version	X.X.X	---	---	---
Par. 9.13	<b>User preferences</b>				
	Sound alarm	Enabled	---	---	Disabled
	Sound keyboard	Enabled	---	---	Disabled
	Date & Time	...	---	---	---
	Modification locking code	No	0000	9999	0000 ÷ 9999
	Date	dd/mm/yy	---	---	---
	Time	hh:mm:ss	---	---	---
	Display contrast	5	01	10	02 ÷ 09
	Filling calc.	Disabled	---	---	Enabled
	Displayed data	...	---	---	---
	Left	Pressure	---	---	Covered area - Tank data - Flowrate - RPM - TC icons
	Middle	Tank data	---	---	Pressure - Covered area - Flowrate - RPM - TC icons
	Right	Flowrate	---	---	Pressure - Covered area - Tank data - RPM - TC icons
	Tank data	Level (l) Level (gal)	---	---	Both (l-ha) - Both (l-km) Both (gal-ac) - Both (gal-miles)
Par. 9.14	<b>Data logger</b>	Disabled	---	---	1 sec. - 2 sec. - 5 sec. - 10 sec.
Par. 9.15	<b>Ext. device log</b>	5 sec.	1 sec.	10 sec.	2 sec.
Par. 9.16	<b>Load/save setup</b>	...	---	---	---
	Load configuration from USB	---	---	---	---
	Save configuration from USB	---	---	---	---
	Restore factory	---	---	---	---

Fig. 46

9.1 Job selection

Select > the job to enable \*.

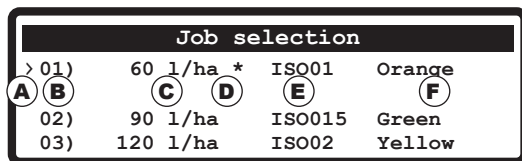

Fig. 47

- A > Selected job
- B 01) Job number
- C 60 l/ha Target rate
- D \* Active job
- E ISO01 Nozzle type: (ISO code / User nozzle)
- F Orange Nozzle type: (Color / User nozzle)

9.2 Current Job data

Displays the data of the current spraying (active job).

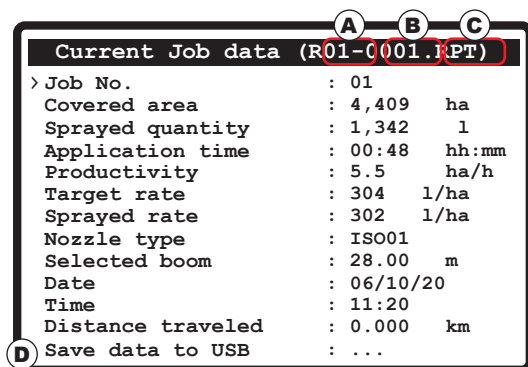

Fig. 48

- A R01 Job number
- B 0001 Progressive number of saved file
- C .RPT Extension of saved file

Application time	Covered area	Distance traveled
Counting enabled with:	Counting enabled with:	Counting enabled with:
Master ON	Master ON + Flowrate ON	Master OFF

Select the item **D** > Save data to USB and press **OK**.  
 Bravo 350 saves a file containing all the displayed data to the USB  
 e.g.: R01-0001.RPT.  
 Bravo 350 will increase the report number upon each subsequent saving e.g.:  
 R01-0002.RPT.

Data in the file can be displayed on PC with a text editor.

9.3 Jobs setup

In this menu it is possible to set 40 different types of treatments.

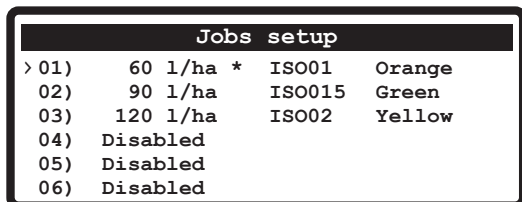

Fig. 49

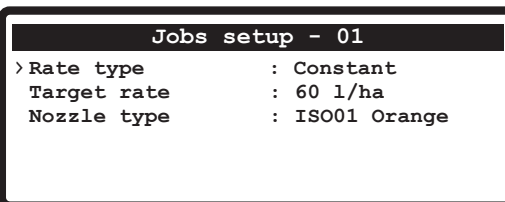

Fig. 50

First of all select the job to be set (Fig. 49) and enter the features (Fig. 50).  
 Repeat the setup for each job (set the used types and disable the others).

FEATURES TO BE SET FOR EACH JOB:

- > **Target rate**: Set the spray rate value for the selected treatment.
  - > **Nozzle type**: Select the nozzle type for the selected treatment.
- Par. 9.4 Nozzles setup.

9.4 Nozzles setup

From this menu, set two types of nozzles: ISO and User.

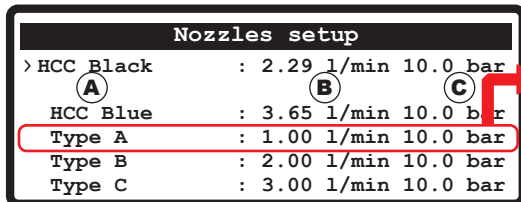

Fig. 51

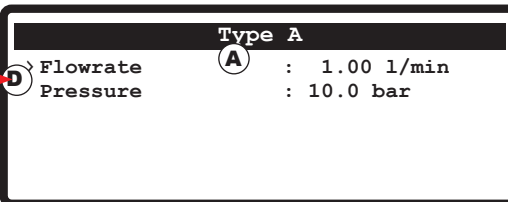

Fig. 52

- A** Nozzle type
- B** Reference flowrate
- C** Reference pressure
- D** Reference /Pressure / Flowrate

First select the nozzle to be set (Fig. 51) and enter the flowrate (Fig. 52).

The flowrate of the nozzle being used allows BRAVO 350 to calculate the pressure without a pressure sensor.

Repeat the setup for each available "user" nozzle.

**Pressure can be changed ONLY for nozzles of TYPE A+J (User nozzle).**

**Flowrate can be changed ONLY for nozzles of TYPE A+J (User nozzle).**

NOZZLES

Nozzle color	Unit of measurement METRIC METR. l/100m		Unit of measurement US	
	Flowrate (l/min)	Pressure (bar)	Flowrate (GPM)	Pressure (PSI)
ISO005 Purple	0.20	3.0	0,050	40
ISO0075 Pink	0.30	3.0	0,070	40
ISO01 Orange	0.40	3.0	0,100	40
ISO015 Green	0.60	3.0	0,150	40
ISO02 Yellow	0.80	3.0	0,200	40
ISO025 Lilac	1.00	3.0	0,250	40
ISO03 Blue	1.20	3.0	0,300	40
ISO04 Red	1.60	3.0	0,400	40
ISO05 Brown	2.00	3.0	0,500	40
ISO06 Gray	2.40	3.0	0,600	40
ISO08 White	3.20	3.0	0,800	40
ISO10 Cyan	4.00	3.0	1,000	40
ISO15 Li Green	6.00	3.0	1,500	40
ISO20 Black	8.00	3.0	2,000	40

Nozzle color	Unit of measurement METRIC METR. l/100m		Unit of measurement US	
	Flowrate (l/min)	Pressure (bar)	Flowrate (GPM)	Pressure (PSI)
Type A	1.00	5.0	0,264	73
Type B	2.00	5.0	0,528	73
Type C	3.00	5.0	0,793	73
Type D	4.00	5.0	1,057	73
Type E	5.00	5.0	1,321	73
Type F	6.00	5.0	1,585	73
Type G	7.00	5.0	1,849	73
Type H	8.00	5.0	2,113	73
Type I	9.00	5.0	2,378	73
Type J	10.00	5.0	2,642	73

00,01 ÷ 99,99      00,003 ÷ 26,417

Tab. D

Minimum pressure alarm: below the set pressure value, the system will trigger an insufficient pressure alarm.

Maximum pressure alarm: above the set pressure value, the system will trigger an excessive pressure alarm. See par. 11.2 on page 41.

9.5 Working parameters

From this menu it is possible to set the farming machine working parameters.

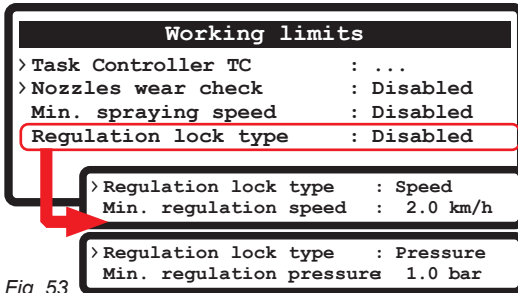

The set limits are active **ONLY** during the **AUTOMATIC OPERATION** (Par. 10.7.1).

Fig. 53

9.5.1 Task Controller TC

**Menu visible only if the item External device > IBX20is enabled.**

With the connection to IBX20 Task Controller (enabled in par. 8.10), the computer can activate the following work functions and display them on the work screen:

- > **TC-BAS**  
Job's data recording
- > **TC-SC**  
Automatic section closing
- > **TC-GEO**  
Variable application rate

9.5.2 Nozzles wear check

Activate the alarms by pressing F4 (page 13) and indicate the percentage.

**This alarm can be enabled ONLY if the system features both flowmeter and pressure sensor:** BRAVO 350 compares the effective flowrate read by the flowmeter and the one calculated by the pressure sensor. When the difference between the two flowrate values exceeds the set percentage, the alarm is triggered.

9.5.3 Min. spraying speed

Activate the alarms by pressing F4 (page 13) and indicate the value.

BRAVO 350 interrupts the spraying, by disabling the main valve, when the detected speed is lower than the set one.

9.5.4 Regulation lock type

BRAVO 350 interrupts the automatic regulation of the proportional valve when the detected speed or pressure are lower then the set limits. The menu items change according to the set data (Fig. 53).

9.6 Rate controller

From this menu it is possible to set the farming machine rate controller.

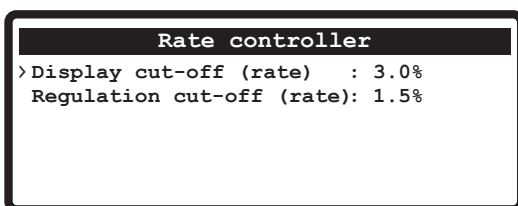

> **Display cut-off (rate)**

Indicate the rate display tolerance percentage beyond which the alarm is triggered and the system displays the actual rate value. Within the set percentage, the system continues displaying the preset rate even if different from the actual one.

> **Regulation cut-off (rate)**

Indicate the percentage of tolerance relative to the application rate target beyond which the control valve no longer regulates because it considers it to have been reached.

Fig. 54



The set limits are active **ONLY** during the **AUTOMATIC OPERATION** (Par. 10.7.1).

9.7 Tank

It activates the tank filling procedure.

The filling will be managed in different ways according to the mode preset in the menu **Tank level** (Par. 8.7).

**Tank level - Manual Mode (Par. 8.7.1)**

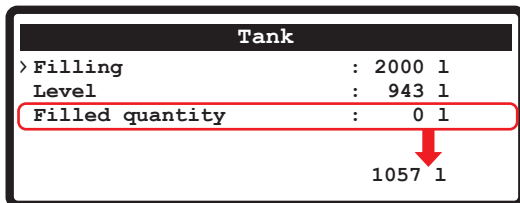

Fig. 55

> Filling

BRAVO 350 displays the tank rated capacity: the value has been set in **Advanced setup > Tank level > Capacity**.

> Level

BRAVO 350 displays the quantity of fluid inside the tank, calculated according to the job data. It offers the possibility of manually filling the tank by editing the value of the volume of filled fluid.

> Filled quantity

It is the difference between the value of the tank level and that of the fluid level actually filled.

Negative and positive values can be displayed.

**Tank level - Level Sensor Mode (Par. 8.7.2)**

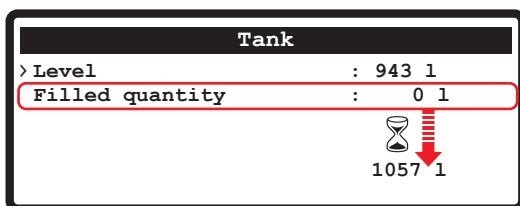

Fig. 56

> Level

BRAVO 350 displays the real quantity of fluid inside the tank, detected by the level sensor.

> Filled quantity

Start the filling pump and stop it at the end of the filling procedure. The display shows the fluid filling data in real time.

**Tank level - Filling Flowmeter Mode (Par. 8.7.3)**

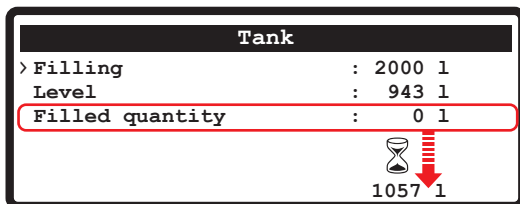

Fig. 57

> Filling

BRAVO 350 displays the tank rated capacity: the value has been set in **Advanced setup > Tank level > Capacity**.

> Level

BRAVO 350 displays the quantity of fluid inside the tank, calculated according to the job data.

> Filled quantity

Start the filling pump and stop it at the end of the filling procedure. The display shows the filling data in real time.

For all the described modes if the following menu item is active: **User setting > User preferences > Filling calc. > enabled** in the menu **Tank** the display will show the item **> Estimated quantity need** (par. 9.13.5).

9.8 Speed

Usually the computer calculates the information concerning the speed thanks to pulses received by the sensor installed on the wheel. Alternatively, it is possible to use a GPS receiver directly connected to the BRAVO 350 or a Bravo400S or Delta80 satellite navigator (properly connected). This menu allows selecting the speed data provided by the GPS signal as an alternative speed source.

In this menu carry out all settings to calculate the speed.

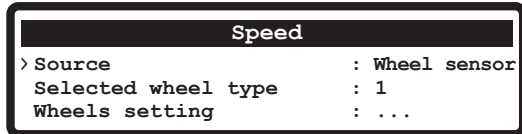

Fig. 58

First of all select the source used by BRAVO 350: set the submenu **Source** and the data concerning the selected option.

Possible options:

> **Wheel sensor** : Par. 9.8.1

> **GPS**: Par. 9.8.2

> **Tractor wheel**: the menu appears **ONLY IF External device > IBX20 par. 8.10 on page 21 is selected in advanced settings.**

The IBX20 control unit receives the vehicle travel speed via the ISOBUS line. The speed value is provided by the Tractor-ECU according to the rotation speed of the wheel or a mechanical part.

> **Tractor radar**: the menu appears **ONLY IF External device > IBX20 par. 8.10 on page 21 is selected in advanced settings.**

The IBX20 control unit receives the vehicle travel speed via the ISOBUS line. The speed value is provided by the Tractor-ECU that detects the data sent by the radar installed on the tractor.

9.8.1 Source - Wheel sensor

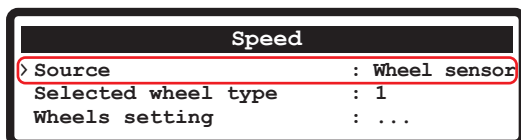

Fig. 59

> **Selected wheel type**: select the type of wheel (3 types available).  
 > **Wheels setting**: set the wheel constant (3 available).  
 The constant can be inserted with two different procedures (manual or automatic), described below.



**Take measurements with tires at the operating pressure.**  
**This test must be performed on medium-hard terrain; for application to very soft or very hard terrain, rolling diameter may vary, leading to inaccurate output calculation; when this is the case, repeat the procedure.**  
**During the test, cover the distance with the tank filled up to half capacity with water.**

**Constant calculation: Manual**

Allows to enter the wheel constant value calculated with the suitable formula.

$$K_{\text{wheel}} = \frac{\text{distance traveled (cm)}}{\text{no. of detection points} \times \text{wheel rpm}}$$

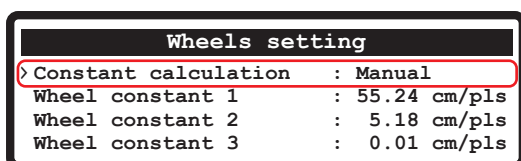

Fig. 60

<**distance traveled**> distance expressed in cm covered by the wheel along measurement travel.  
 <**no. of measurement points**> number of measurement points (e.g. magnets, bolts, etc.), mounted on wheel.  
 <**no. of wheel revolutions**> number of wheel revolutions required to travel measurement distance.

The wheel constant can be calculated with a good approximation by detecting the distance traveled by the wheel with the speed sensor.  
 (The longer the distance traveled, the more accurate wheel constant calculation).

Select the **Wheel constant 1, 2 or 3** and enter the calculated value.

**Constant calculation: Automatic**

It allows to calculate and save the wheel constant with the formula below:

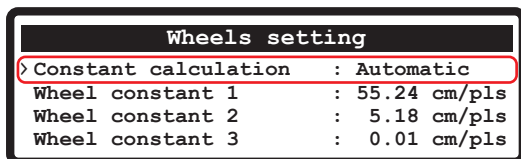

Fig. 61

- Measure a straight path at least 100 m (300 feet) long.  
 (The longer the distance traveled, the more accurate wheel constant calculation).
- Select a constant (**Wheel constant 1, 2 or 3**) and press **OK** to access automatic setup.
- Set the value of the **Reference distance** to be covered (**A**).
- Select the item **Start counting** and press **OK** to confirm.
- Travel the requested distance: the number of pulses will increase during the path. Stop the tractor at the end of the distance.
- Press **OK** to stop the counting. The computer will indicate the calculated constant.  
 Wheel constant has been saved.

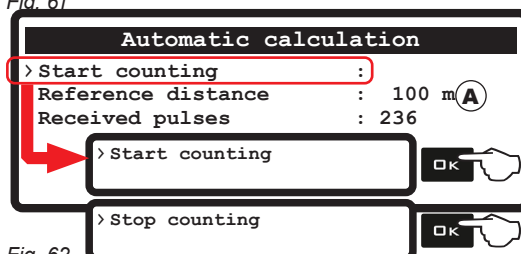

Fig. 62

9.8.2 Source - GPS

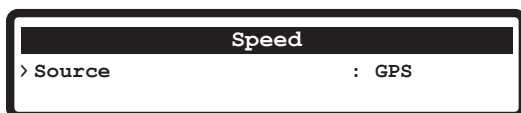

Fig. 63

The computer receives the speed data from the GPS receiver or from the Bravo400S or Delta80 satellite navigator directly connected to the auxiliary port.  
 If Bravo 400S and Delta 80 are used, select **External device > B400S/D80** in the advanced settings par. 8.10 on page 21.

9.9 Flowrate correction factor

When using a paddle flowmeter and the sprayed fluid has a different density than the water one, the computer could display wrong measurements; to correct them change the sprayed fluid factor:

- if at the end of the spraying the tank still contains fluid, reduce the factor;
- if the fluid finishes before the job has ended, increase the factor.

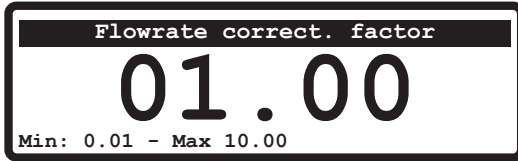

Fig. 64

Set the density factor of the sprayed fluid.



Flowmeters of the ORION series (code 462xxx) are not affected by the density difference of the fluids: set the factor to 1.00.

9.10 Press. sensor zero value

Menu visible only if the pressure sensor is enabled in the menu **Advanced Setup**.

Activate the "zero" calibration procedure of pressure sensor.

In case a pressure value is displayed **despite the absence of pressure inside the circuit**, it is necessary to perform zero setup of the sensor:

**Before carrying out any operation disable the pump.**

Make sure that the pump is correctly disabled, then open the main valve and all section valves.

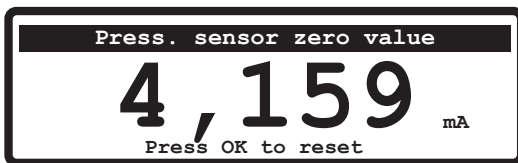

Fig. 65

The value read by the level sensor must be within 3.0 mA and 5mA.

- Press **OK** to reset the pressure sensor residual signal.

Bravo 350 automatically quits the procedure and displays the job screen with the pressure value of 0.0 bar.

9.11 Totalizers

This menu allows displaying the job TOTAL data of the computer.

Consider that:

- There is a totalizer for each preset job (40 available): upon access the display shows the active job totalizer.
- You can scroll the totalizer referred to the job number by pressing **F1** and **F2**.
- The current job data are summed to the relevant totalizer each time you select a new job (Par. 9.1).
- It is possible to save the totalizer reports on USB pendrive using the relevant function **Save data to USB** (Fig. 66).
- It is possible to delete all job's data (Fig. 67).

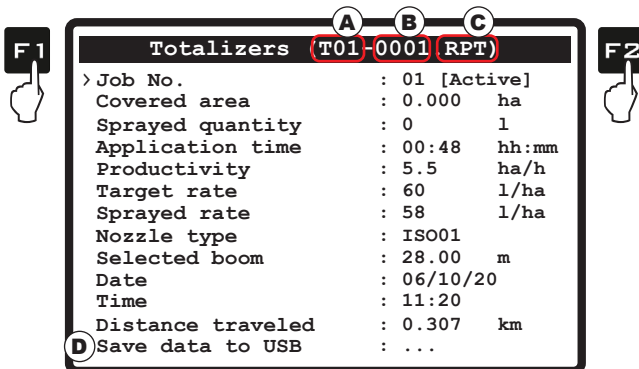

Fig. 66

- A** T01 Job number
- B** 0001 Progressive number of saved file
- C** .RPT Extension of saved file

• **SAVING THE TOTALIZER ON USB PENDRIVE**

Select the item **D** > **Save data to USB** and press **OK**: at the end of the saving operation, **Successfully completed!** will be displayed. Bravo 350 saves a file containing all the displayed data to the USB.

E.g.: T01-0001.RPT.

Bravo 350 will increase the report number upon each subsequent saving e.g.: T01-0002.RPT.

Data in the file can be displayed on PC with a text editor.

• **TOTALIZER RESET**



**CAUTION: IN THIS WAY ALL JOB (TOTAL) DATA SAVED SO FAR WILL BE LOST. WE RECOMMEND SAVING THEM ON USB PENDRIVE BEFORE PROCEEDING.**

- Select item **Job No.** (Fig. 66) and press **CLR**.

- The screen of Fig. 67 will be displayed: select **Yes** and press **OK**.

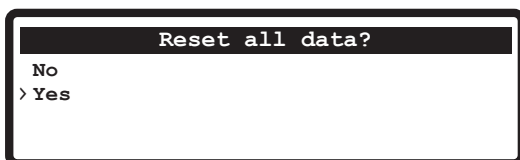
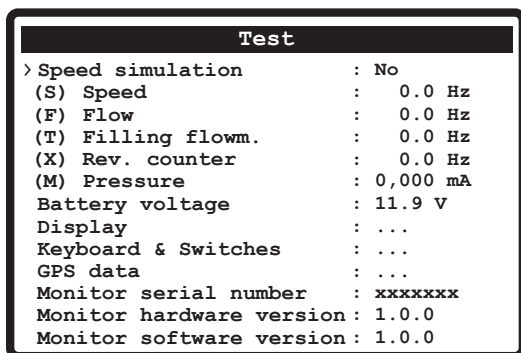

Fig. 67



9.12 Test



It allows checking the correct operation of BRAVO 350.

 All items are read-only

Fig. 68

9.12.1 Speed simulation

Allows enabling **Yes** /disabling **No** speed simulation.

The simulation allows carrying out regulation tests also with stopped machine: simulation set at 6 km/h (3.7 MPH).

**Simulation speed modification:**

Once the speed simulation has been enabled, press **OK** on the job screen to edit the speed value: **S** the symbol is blinking.

Press the key **▲** to increase the simulated speed and the key **▼** to decrease it.

Press **OK** to confirm the value: **S** the symbol is steady.

9.12.2 Signal test

The computer detects frequency or current sent by each sensor correctly connected to the system.

9.12.3 Battery voltage

BRAVO 350 displays the supply voltage.

9.12.4 Display

The computer switches on each string of the display progressively to check that all pixels turn on.

After the test, press **ESC** to quit.

9.12.5 Keyboard & Switches

Press all keys or switches one at a time: if the operation is correct, the display will show the name of the relevant control.

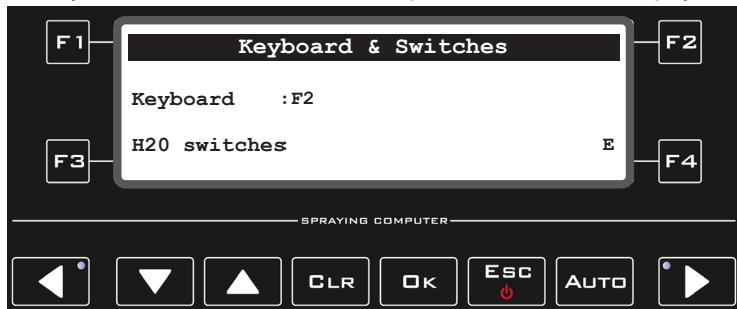

Fig. 69

**Keyboard:**  
 F1 / F2 / F3 / F4  
 LEFT  
 DOWN / UP / CLR / OK / ESC / Auto  
 RIGHT

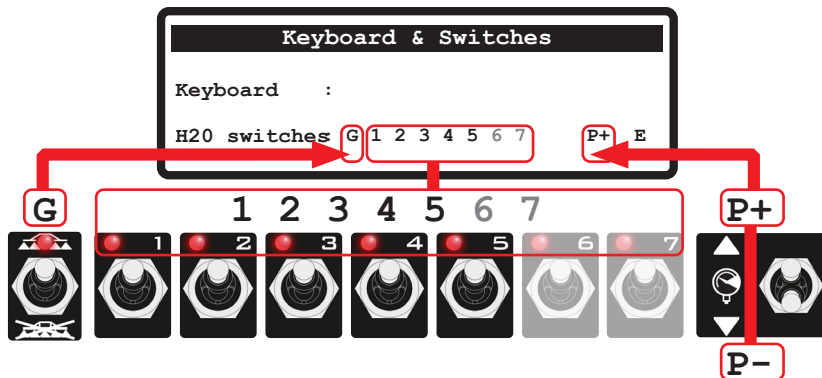

Fig. 70

**H2O switch:**  
 G Main control ON  
 1 / 2 / 3 / 4 / 5 / 6 Section valves ON  
 P+ / P- Proportional regulation  
 (+ increase / - decrease)  
 E Presence of an external main control to start the spraying.

9.12.6 GPS data

If you connect a satellite receiver, BRAVO 350 displays the received GPS data.

Displayed data:

- Latitude
- Longitude
- Number of satellites
- HDOP
- DGPS
- Update frequency

9.12.7 Monitor hardware version - Monitor software version

BRAVO 350 displays the hardware and software version of the device.

9.13 User preferences

This menu allows setting the BRAVO 350 audio and display preferences.

9.13.1 Sound alarm

Enables or disables the sound when alarms are triggered.

9.13.2 Sound keyboard

Enables or disables keytones.

9.13.3 Date & Time

Allows setting the computer clock.

> **Modification locking code**

Allows locking the modification of date and time set on the computer to obtain real reports.

• **HOW TO USE THE LOCKING CODE**

- Enter the number to enable the locking;
- Enter the same number if you want to disable the data modification locking.

> **Date**

> **Time**

Set the BRAVO 350 date and time.

• **HOW TO SET DATE AND TIME**

- Select the items **Date** or **Time** and press **OK** to access the edit mode; now press the keys **▲ ▼** to change the digits and **◀ ▶** to scroll through the fields. Press **OK** to confirm.
- Once all fields have been set, BRAVO 350 automatically quits the menu.

9.13.4 Display contrast

Allows adjusting the display contrast.

9.13.5 Filling calculation

It allows enabling / disabling the estimated quantity needed for the treatment (par. 9.7 Tank).

By specifying the extension of the area to be sprayed, Bravo 350 will be able to estimate the fluid quantity needed for the spraying considering the quantity of fluid present in the tank and the target rate.

9.13.6 Data display

It allows selecting the data displayed in the lower part of the job screen.

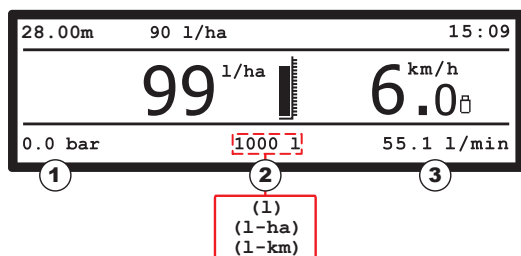

Fig. 71

- 1 Left
- 2 Middle
- 3 Right

1 - 2 - 3 Available options for each data:

- RPM
- Pressure
- Covered area
- Flowrate
- Tank data

TC icons: TC-GEO , TC-SC , TC-BAS  functions.

For all the enabled functions related to the **User setting > Working parameters > Task Controller TC** menu (par. 9.5.1), it is possible to select the item **TC icons** in one of the **Left / Middle / Right** menus.

The work screen will display the icons in the desired position.

Available options for **Tank data** (2, Fig. 71):

**Level** (l) or (gal): the display indicates the tank level in real time.

**Level and surface:**

**Both** (l-ha) or (gal-ac):

the display will show alternatively the tank level and the estimated remaining area (ha or ac depending on the set units of measurement) counted according to speed, application rate and number of open section valves.

**Level and distance:**

**Both** (l-km) or (gal-miles):

the display will show alternatively the tank level and the estimated remaining distance (km or miles depending on the set units of measurement) counted according to speed, application rate and number of open section valves.

the display will show alternatively the tank level and range (km or miles according to the set units of measurement).



**In case the item Both is set, the values on the spraying screen are displayed alternatively.**



9.14 Data logger

It allows enabling / disabling the job data saving on the USB pendrive.  
Set a saving interval (1, 2, 5, 10 seconds) to enable data logger.

If you connect a satellite receiver or a navigator, the **Data logger** (correctly enabled) allows recording also the latitude and longitude of the machine at any moment of the spraying.

**DATA RECORDING FILE**

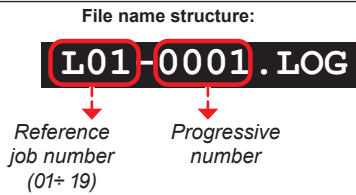

When the data logger is enabled, BRAVO 350 saves a "LOG" file to the USB pendrive, where the job data will be saved\*. The recording is activated when the main control is ON, and is carried out at the frequency set in the **Data logger** menu.

Any time you select a job, a new "LOG" file will be saved and its name (Fig. 72) will bear a progressive number according to the number of savings (i.e.: 00001 → 00002).

Data in the file can be displayed on Personal Computer with a text editor.  
They consist of a header followed by data strings.

Fig. 72

Example:

B350\_DIR,1.0.0,S,1,19/03/2019,09:56:06,44.64226197,10.78941207,0,3.1,28.00,910.411,60,0.15,2.7,2.0,660,1982,1111110,4.00,4.00,4.00,4.00,4.00,4.00,4.00,ISO01 Orange,J1

DATA	HEADERS	DESCRIPTIONS	AVAILABLE OPTIONS
B350_DIR	Device	Device	
1.0.0	FwVersion	Firmware version	
S	SwType	Software type	S = crop sprayer
1	GPSQ	GPSQ	
19/03/2019	Date	Date	
09:56:06	Time	Time	
44.64226197	Lat	Latitude	
10.78941207	Lon	Longitude	
0	MUnit	Unit of measurement	0: metric / 1: US
3.1	Speed	Speed	
28.00	BoomWidth	Boom width	
910.411	CoveredArea	Covered area	
60	TargetRate	Target rate	
0.15	ActRate	Sprayed rate	
2.7	Flow	Flowrate	
2.0	Press	Pressure	
660	SprQty	Sprayed quantity	
1982	TankLevel	Tank level	
1111110	Sections	Section status	0: closed / 1: open
4.00	Sect1Whidt	Section 1 width	
4.00	Sect2Whidt	Section 2 width	
4.00	Sect3Whidt	Section 3 width	
4.00	Sect4Whidt	Section 4 width	
4.00	Sect5Whidt	Section 5 width	
4.00	Sect6Whidt	Section 6 width	
4.00	Sect7Whidt	Section 7 width	
	RPM	Rotation speed	
ISO01 Orange	ActNozzles	Nozzle type	
J1	SelectedJob	Job number	

\* These data represent just a mere example. In real facts they will always be different according to the type of spraying.

9.15 Ext. device log

Menu only visible if a menu item "8.10 External device" on page 21 has been set in the Advanced setup.  
Used to set the seconds of the sampling period transmitted through the serial port.

9.16 Load/save setup

The BRAVO 350 settings can be loaded or saved on USB pendrive so as to reconfigure the device if necessary, solve problems or configure another BRAVO 350 without repeating all operations manually.



**Once installation is completed, and you checked machine correct operation, we recommend you to store the whole configuration on the USB pendrive.**

To use the menu items insert the USB pendrive in the suitable slot.

9.16.1 Load configuration from USB

It allows selecting a configuration file saved on the USB pendrive and to set BRAVO 350 again.



**CAUTION: BY LOADING THE B350SPR.BIN FILE CONTAINED IN THE USB MEMORY IN BRAVO 350, ALL SETTINGS CARRIED OUT SO FAR WILL BE LOST.**

- Select **Load configuration from USB** and press **OK**;

The confirmation message **Successfully completed! (B350SPR.BIN)** is displayed once the configuration process is completed.

- Press **ESC**.

9.16.2 Save configuration to USB

It allows saving the BRAVO 350 configuration on the USB pendrive: then it will be possible to load it any time it is necessary to repeat the same settings.

- Select **Save configuration to USB** and press **OK**;

The confirmation message **Successfully completed! (B350SPR.BIN)** is displayed once the saving process is completed.

- Press **ESC**.



**WARNING: if you save two different Bravo 350 configurations on the same USB pendrive, the second one will overwrite the first one.**

9.16.3 Restore factory

It allows restoring factory default settings of the system.

The device will be restarted.



**All data and configurations WILL BE LOST.**

10 USE

10.1 Controls on computer



Fig. 73

Legend:

- 1 Keys to select data or modify parameters
- 2 Foam marker control keys
- 3 Operating switches for control unit valves
- 4 Switches to use hydraulic functions (control unit valves), if any

10.2 Control, selection or modification keys (1 - 2 Fig. 73)

LEFT Foam marker	Decrease / scroll data	Increase / scroll data	Data reset	Data confirmation	ON/OFF Quit data modification	Output Manual / Automatic	RIGHT Foam marker

10.3 Switches to operate valves in the control unit (3 Fig. 73)

If the main control is set to ON, the message *Disable spraying command!* will be displayed: no function can be accessed until the main control is set to OFF.

Main control ON	Main control OFF	Enabled section	Disabled section	Increase of output	Decrease of output

10.4 Switches to use the hydraulic functions (4 Fig. 73)

Boom release	Boom lock	Boom counter- clockwise leveling	Boom clockwise leveling	Boom height increase	Boom height decrease	Boom section movement: opening	Boom section movement: closing
	The LED turns on when one of the possible sprayer movements is activated. Keep the relevant switch pressed to activate the movement. Release it to stop the movement.						

10.5 Display

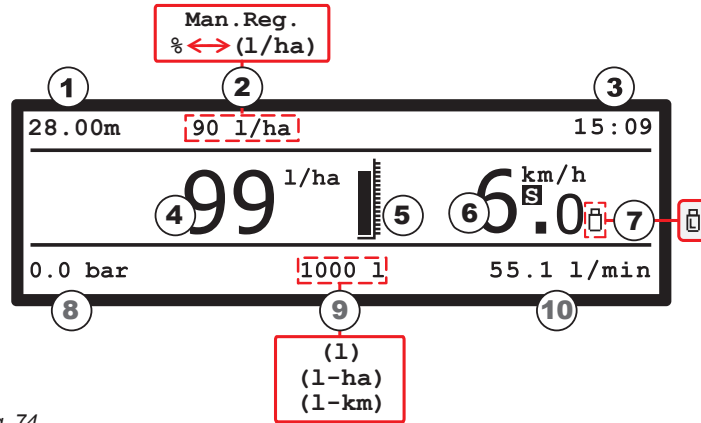







Fig. 74

- 1 Boom width
  - 2 Manual mode **Man . Reg .** / Programmed application rate (Automatic mode) e.g.: 90 l/ha
  - 3 Clock
  - 4 Detected output
  - 5 Tank level graphic indicator
  - 6 Detected / Simulated speed
  - 7 USB pendrive correctly detected:  
when the data logger is enabled (**User setting > Data logger**) the letter **L** is shown inside the icon.
  - 8 - 9 - 10 Customizable data display:  
**RPM / Pressure / Covered area / Tank data / Flowrate / TC icons** (can be activated separately **TC-GEO** , **TC-SC** , **TC-BAS** ).
- Example:
- 8 Pressure
  - 9 Tank data: tank level (*text and graphic*), alternated with
    - Level and surface (*ONLY if set among the user preferences, Par. 9.13*)
    - Level and distance (*ONLY if set among the user preferences, Par. 9.13*)
  - 10 Flowrate

10.6 Treatment preliminary settings

SET		
<b>TO BE CARRIED OUT UPON FIRST USE OF THE COMPUTER</b>	Speed	<b>9.8</b>
	Jobs setup	<b>9.3</b>
	Nozzles setup	<b>9.4</b>
	Working limits	<b>9.5</b>
	Flowrate correction factor	<b>9.9</b>
	User preferences	<b>9.13</b>
	Date & Time	<b>9.13.3</b>
	Data logger	<b>9.14</b>
Save settings to USB pendrive	<b>9.16.2</b>	
<b>TO BE PERFORMED OR CHECKED BEFORE ANY TREATMENT</b>	Type of wheel	<b>9.8.1</b>
	Flowrate correction factor	<b>9.9</b>
	Type of job	<b>9.1</b>
	Tank parameter	<b>9.7</b>
	Totalizers reset (option)	<b>9.11</b>
Job's data recording (option)	<b>9.14</b>	

 After having carried out the indicated settings, start the treatment selecting **MANUAL** (Par. 10.7.2) or **AUTOMATIC** (Par. 10.7.1) mode.

## 10.7 Application rate regulation

BRAVO 350 regulates the chemical products output in two different ways: Manual Mode and Automatic Mode.

Press **AUTO** to select the desired mode to be displayed: **Man. Reg.** (Manual Mode) e.g.: **90 l/ha** (Automatic Mode)

### 10.7.1 Automatic operation





Fig. 75

BRAVO 350 keeps the target rate constant regardless of the changes in speed and boom section status.

If necessary, during spraying, it is possible to intervene on the dedicated switch **6** to adjust output to crop conditions, increasing or decreasing momentarily the application rate up to  $\pm 50\%$ .

- 1 Enable the automatic operation.
- 2 Activate the desired section valves.
- 3 Position the tractor at the beginning of the field to be sprayed.
- 4 Turn the main switch to ON.
- 5 Start spraying.
- 6 Use the control valve switch to temporarily change the application rate.

If **IBX20** is enabled (par. 8.10), pressing the **AUTO** button will **ACTIVATE** both the **TC** enabled (**TC-GEO** , **TC-SC** , **TC-BAS** ) in par. 9.5.1, and the application rate target.

Par. 10.2 Control, selection or modification keys (1 - 2 Fig. 73)

Par. 10.3 Switches to operate valves in the control unit (3 Fig. 73)

Par. 10.5 Display





### 10.7.2 Manual operation (DEFAULT)



Fig. 76

Application rate shall be adjusted manually using the suitable **6** switch.

- 1 Enable the manual operation.
- 2 Activate the desired section valves.
- 3 Position the tractor at the beginning of the field to be sprayed.
- 4 Turn the main switch to ON.
- 5 Start spraying.
- 6 Use the control valve switch to adjust the desired quantity.

If **IBX20** is enabled (par. 8.10), pressing the **AUTO** button will **DEACTIVATE** both the **TC** enabled (**TC-GEO** , **TC-SC** , **TC-BAS** ) in par. 9.5.1, and the application rate target. If enabled, the **TC-BAS**  function switches to manual mode.

Par. 10.2 Control, selection or modification keys (1 - 2 Fig. 73)

Par. 10.3 Switches to operate valves in the control unit (3 Fig. 73)

Par. 10.5 Display

### 10.7.3 Automatic closure of section and main valves (via Bravo 400S / Delta 80)

BRAVO 350 can automatically close section and main valves with the help of Delta 80 / Bravo 400S navigator.

It manages autonomously the opening and closing of the valves, avoiding overlapping already covered areas. In order to use the automatic closing feature, connect Bravo 400S and Delta80 (by means of a harness available in the Arag catalog) to BRAVO 350 and carry out the procedure for **AUTOMATIC** operation (Par. 10.7.1): for further information, refer to the specific instructions enclosed with Delta 80 and Bravo 400S satellite navigator.

**WARNING: automatic closure is NOT active during manual operation.**



**11 MAINTENANCE / DIAGNOSTICS / REPAIRS**

**11.1 Cleaning rules**

- Clean only with a soft wet cloth.
- DO NOT use aggressive detergents or products.
- Do not clean the monitor with direct water jets.

**11.2 Operation errors**

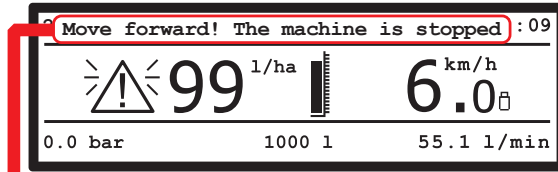

Par.	WORKING MODE	MESSAGE ON DISPLAY / CAUSE	SOLUTION
8.7.2 9.16	MAN. + AUTO	USB device not detected! USB device not connected! The USB pendrive is not inserted correctly	• Check the insertion of the USB pendrive.
8.7.2 9.16	MAN. + AUTO	USB memory full! The USB pendrive has no free space	• Space needed for new information: delete the unnecessary files from the USB pendrive.
9.16	MAN. + AUTO	File not found! (B350SPR.BIN) The computer configuration has not been saved	• Save the data.
9.16	MAN. + AUTO	File format error! (B350SPR.BIN) The file relevant to the computer configuration is faulty.	• Try to save the data again.
8.7.2	MAN. + AUTO	File not found! (TANK.TKL) The tank configuration has not been saved	• Save the data.
8.7.2	MAN. + AUTO	File format error! (TANK.TKL) The file relevant to the tank configuration is faulty.	• Try to save the data again.
9.7	MAN. + AUTO	WARNING! Maximum level reached You have reached the maximum capacity of the tank	• Stop the loading pump: you have reached the maximum capacity of the tank.
8.4	MAN. + AUTO	Flowmeter out of range Flowrate out of the limits allowed by flowmeter	• Regulate the operating pressure so as to respect the previously set limits for nozzles in use. • Check that the flowmeter constant value has been set correctly.
9.3	AUTO	Slow down! Insufficient flowrate The flowrate does not reach the value required for output	• Decrease the farming machine speed. • Check that the flowmeter constant value has been set correctly.
9.3	AUTO	Accelerate! Too high flowrate! The flowrate exceeds the value required for output	• Increase the farming machine speed. • Check that the flowmeter constant value has been set correctly.
8.8	MAN. + AUTO	Reduce rotation speed! RPM exceeds the maximum allowed value	• Decrease the rotation speed of the moving part.
8.8	MAN. + AUTO	Increase rotation speed! RPM does not reach the minimum value	• Increase the rotation speed of the moving part.
9.8.1	MAN. + AUTO	Error: inadequate number of pulses The automatic calculation of the constant for the wheel sensor is not valid	• Repeat the automatic calculation procedure of the constant for the wheel sensor.
8.7.2	MAN. + AUTO	Signal out of range! Check sensor Faulty pressure values have been detected	• Check the pressure sensor status and make sure there is no residual pressure in the system.
8.7.2	MAN. + AUTO	Signal out of range! Check sensor Anomalous values have been detected	• Check the correct operation of the level sensor. • Check for residual fluid in the tank.
10.3	MAN. + AUTO	Disable spraying command! Main switch ON upon computer switching on	• Move main switch downwards (position OFF).
10.3 10.7.1	AUTO	Move forward! The machine is stopped Main switch ON with machine stopped	• Start the farming machine. • Move main switch downwards (position OFF).
10.5	AUTO	Wrong sections switches status! Simultaneous operation of two different boom sections on the same side	• Disable one of the two sections.
10.7.1	AUTO	Start pump! No flowrate Main switch ON with machine stopped but rate at zero	• Start the pump and move the farming machine.
10.7.1	AUTO	Automatic regulation locked Pressure does not reach set value	• Increase driving speed.
9.12.6	MAN. + AUTO	GPS not valid or not available No connection available or reception problems.	• Check connection and operation of receiver.
9.5	AUTO	Check nozzles! High wear Difference between measured and calculated flowrate (according to selected nozzle data) higher than set value	• Check that the selected nozzle coincides with the one installed. • Replace nozzles.
9.4	AUTO	Accelerate! Insufficient pressure The pressure does not reach the minimum threshold value for the nozzle in use.	• Check whether the entered threshold is compliant. • Check that the selected nozzle coincides with the one installed. • Replace nozzles. • Check the flowmeter and pressure sensor settings, if available.
9.4	AUTO	Slow down! High pressure The pressure exceeds the maximum threshold value for the nozzle in use.	• Check whether the entered threshold is compliant. • Check that the selected nozzle coincides with the one installed. • Replace nozzles. • Check the flowmeter and pressure sensor settings, if available.
6.2	MAN. + AUTO	Overcurrent detected! Current in the valve harness too high.	• Check the power supply status of the farming machine.

**11.3 Troubleshooting**

<b>PROBLEM</b>	<b>CAUSE</b>	<b>SOLUTION</b>
The display does not switch on	No power supply	• Check power supply cable connections ( <b>Par. 6.2</b> ).
	Computer is OFF	• Press the ON key.
Valve controls take no effect	Valves not connected	• Connect the connectors ( <b>Par. 6.4</b> ).
One valve does not open	No power supply to valve	• Check valve electric connection and operation.
The display no longer shows the speed	Wrong setup	• Check the setup of the wheel constant or speed source type ( <b>Par. 9.8.1</b> ).
	No signal coming from the speed sensor	• Check connections to speed sensor or GPS antenna connection ( <b>Cap. 5</b> ).
The displayed speed is not precise	Wrong setup	• Check the setup of the wheel constant ( <b>Par. 9.8.1</b> ).
Output volume readout inaccurate	Wrong setup	• Check the coverage setup and the row width ( <b>Par. 8.3 - 9.3</b> ).
		• Check the setup of the flowmeter constant ( <b>Par. 8.4</b> ).
Covered area count displayed does not match actual distance covered	Wrong setup	• Check the setup of the wheel constant ( <b>Par. 9.8.1</b> ).
		• Check connections to speed sensor ( <b>Chap. 5</b> ).
Distance traveled count displayed does not match actual distance covered	Wrong setup	• Check the row width ( <b>Par. 9.3</b> ).
		• Check the setup of the wheel constant ( <b>Par. 9.8.1</b> ).
Sprayed fluid count displayed does not match liters/gpm actually sprayed	Wrong setup	• Check the setup of the wheel constant ( <b>Par. 9.8.1</b> ).
		• Check connections to speed sensor ( <b>Chap. 5</b> ).
Unable to reach output volume value set for the automatic operation	Wrong setup	• Check the setup of the flowmeter constant ( <b>Par. 8.4</b> ).
		• Check the setup of the type of section valves ( <b>Par. 8.3</b> ).
Instantaneous pressure readout inaccurate	Use of three-way section valves without setting metered by-passes	• Perform setting.
		• Check the setup of the application rate ( <b>Par. 9.3</b> ).
Instantaneous pressure is not displayed	Wrong setup	• Check the row width ( <b>Par. 9.3</b> ).
		• Check maximum pressure valve adjustment.
Rpm readout inaccurate	Wrong setup	• Make sure control valve is adequate for specific system.
		• Check valve operation.
Rpm value not displayed	Wrong setup	• Check the setup of the full scale for pressure sensor ( <b>Par. 8.5</b> ).
		• Check connections to pressure sensor ( <b>Chap. 5</b> ).
The displayed tank level is not precise	Wrong setup	• Check the setup of the pressure sensor ( <b>Par. 8.5</b> ).
		• Check connections to pressure sensor ( <b>Chap. 5</b> ).
During the tank calibration procedure, the sprayed quantity is always steady on zero	Wrong setup	• Check connections to pressure sensor ( <b>Chap. 5</b> ).
		• Check connections to pressure sensor ( <b>Chap. 5</b> ).
The displayed tank level is not precise	Level sensor not calibrated	• Check the setup of the constant for RPM sensor ( <b>Par. 8.8</b> ).
		• Calibrate the level sensor again ( <b>Par. 8.7.2</b> ).
During the tank calibration procedure, the sprayed quantity is always steady on zero	Level sensor wrong installation	• Check connections to RPM sensor ( <b>Par. 8.8</b> ).
		• Check connections to RPM sensor ( <b>Par. 8.8</b> ).
During the tank calibration procedure, the sprayed quantity is always steady on zero	Wrong installation / no flowmeter installed.	• Perform the calibration ( <b>Par. 8.7.2</b> ).
		• Calibrate the level sensor again ( <b>Par. 8.7.2</b> ).
During the tank calibration procedure, the sprayed quantity is always steady on zero	Section valves and main control set to OFF.	• Check connections to level sensor ( <b>Chap. 5</b> ).
		• Check connections to flowmeter ( <b>Chap. 5</b> ).
During the tank calibration procedure, the sprayed quantity is always steady on zero	Section valves and main control set to OFF.	• Install the flowmeter on the system ( <b>Chap. 5</b> ).
		• Set section valves and main control to ON ( <b>Par. 8.7.3</b> ).

**12 ACCESSORIES**

**12.1 Pendrive**

The pendrive may be used to exchange data with BRAVO 350.



**Before using the pendrive, format it in FAT 32 mode; make sure that it is not protected and can be read by the system. Most pendrives with up to 8 Gb memory are compatible.**

**13 TECHNICAL DATA**

**13.1 Computer technical data**

Description	
Display	Graphic LCD, 240 x 64 pixels, white back-lighting
Power supply voltage	9 ± 16 Vdc
Consumption (valves excluded)	3.3W
Max. switchable current for each output (section)	100mA
Max. switchable current for each output (guard actuators)	3A continuous
Operating temperature	-20 °C ± +70 °C -4 °F ± +158 °F
Storage temperature	-30 °C ± +80 °C -22 °F ± +176 °F
Digital inputs	For open collector sensors: max 2000 pls/s
Analog input	4 ± 20 mA
Weight (without cables)	From 900g to 1250g depending on the versions
Protection against polarity inversion	•
Protection against short-circuit	•

**13.2 Pin-out of Bravo 350**

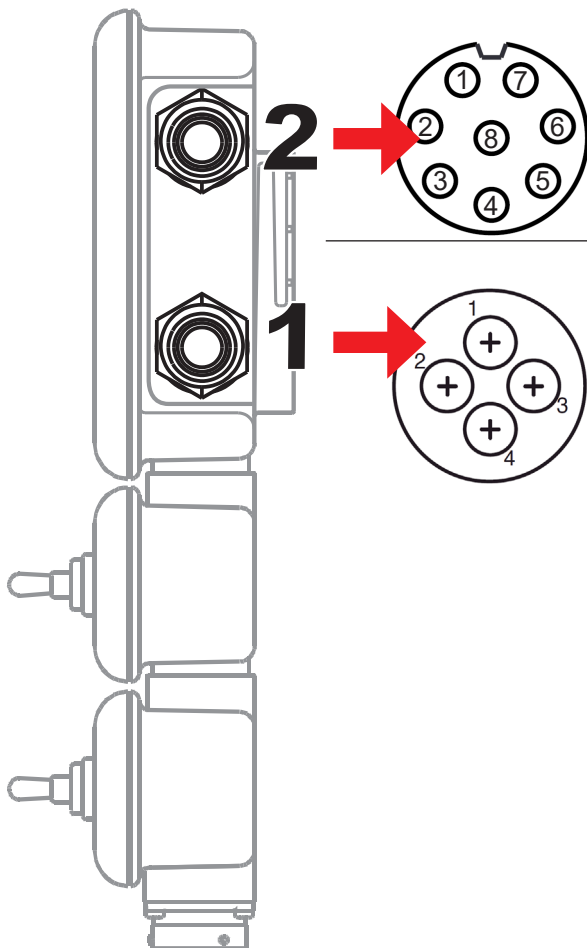

PIN	Signal
1	GPS GND
2	GPS +12 V
3	GPS RX
4	GPS TX
5	External Main Input
6	Secondary speed signal input
7	CAN L
8	CAN H

PIN	Signal
1	GND power supply
2	+ 12V power supply

Fig. 77

CONTINUES

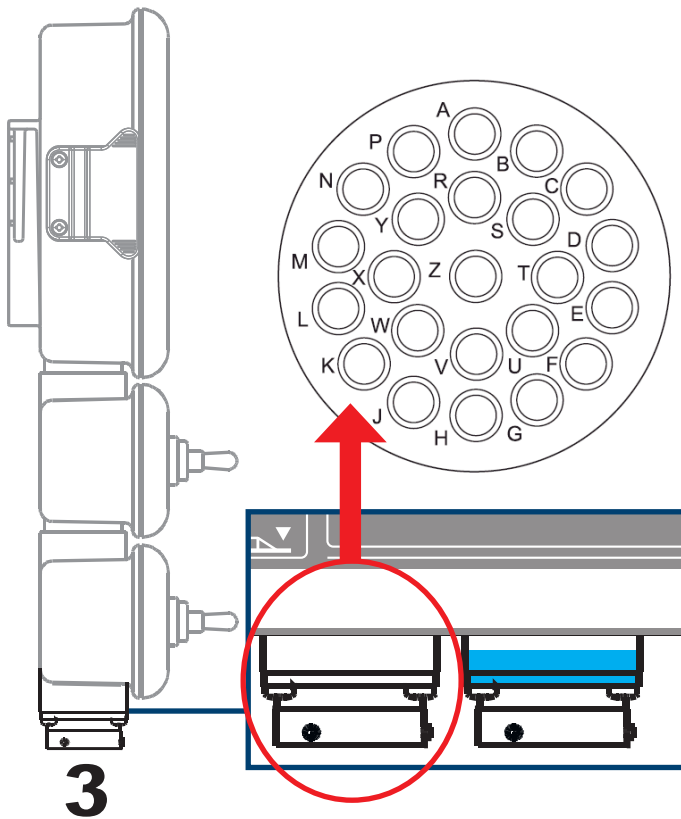

PIN	VERSION W/5-7 SECTIONS	
	Signal	
A	12V sensor power supply	
B	GND sensor power supply	
C	Main valve	
D	12V valve power supply	
E	Section valve 6	
F	Section valve 1	
G	Section valve 7	
H	Section valve 4	
J	Proportional valve (1)	
K	Proportional valve (2)	
L	GND valve power supply	
M	Section valve 2	
N	Level sensor / Filling flowmeter	
P	RPM sensor	
R	Foam Marker 1	
S	Foam Marker 2	
T	Flowmeter	
U	12V valve power supply	
V	Section valve 5	
W	GND valve power supply	
X	Section valve 3	
Y	Speed sensor	
Z	Pressure sensor	

Fig. 78

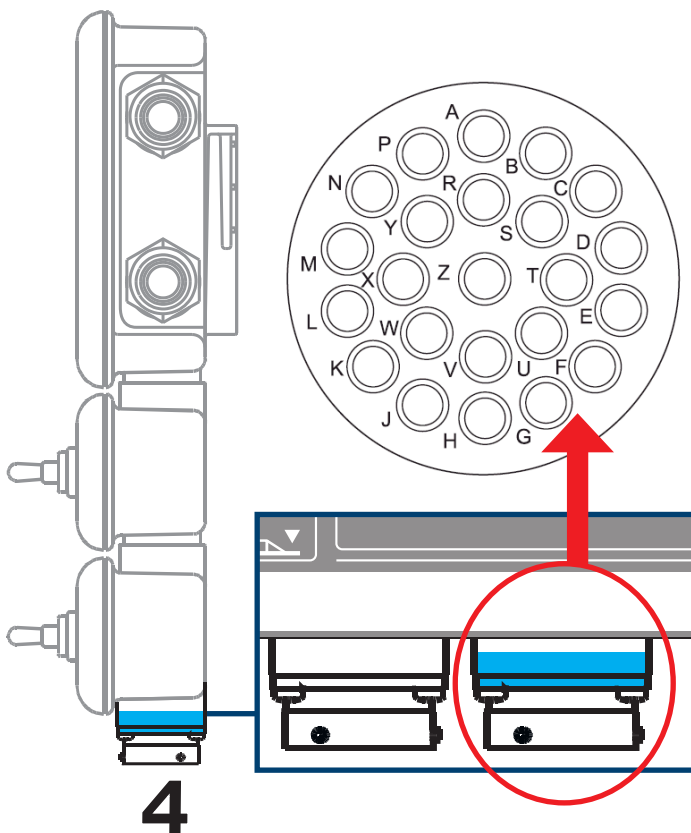

PIN	VERSION W/5-7 SECTIONS	
	Signal	
A	Boom lock (opening)	
B	Boom lock (closing)	
C	Boom leveling (opening)	
D	Boom leveling (closing)	
E	Boom height (opening)	
F	Boom height (closing)	
G	Section 1 movement (opening)	
H	Section 1 movement (closing)	
J	Section 2 movement (opening)	
K	Section 2 movement (closing)	
L	Section 3 movement (opening)	
M	Section 3 movement (closing)	
N	Section 4 movement (opening)	
P	Section 4 movement (closing)	
R	Pilot valve DD	
S	-	
T	-	
U	-	
V	-	
W	-	
X	-	
Y	-	
Z	GND valve power supply	

Fig. 79

---

**14 GUARANTEE TERMS**

---

1. ARAG s.r.l. guarantees this apparatus for a period of 360 days (1 year) from the date of sale to the client user (date of the goods delivery note).  
The components of the apparatus, that in the unappealable opinion of ARAG are faulty due to an original defect in the material or production process, will be repaired or replaced free of charge at the nearest Assistance Center operating at the moment the request for intervention is made. The following costs are excluded:
  - disassembly and reassembly of the apparatus from the original system;
  - transport of the apparatus to the Assistance Center.
2. The following are not covered by the guarantee:
  - damage caused by transport (scratches, dents and similar);
  - damage due to incorrect installation or to faults originating from insufficient or inadequate characteristics of the electrical system, or to alterations resulting from environmental, climatic or other conditions;
  - damage due to the use of unsuitable chemical products, for spraying, watering, weedkilling or any other crop treatment, that may damage the apparatus;
  - malfunctioning caused by negligence, mishandling, lack of know how, repairs or modifications carried out by unauthorized personnel;
  - incorrect installation and regulation;
  - damage or malfunction caused by the lack of ordinary maintenance, such as cleaning of filters, nozzles, etc.;
  - anything that can be considered to be normal wear and tear.
3. Repairing the apparatus will be carried out within time limits compatible with the organizational needs of the Assistance Center.  
No guarantee conditions will be recognized for those units or components that have not been previously washed and cleaned to remove residue of the products used.
4. Repairs carried out under guarantee are guaranteed for one year (360 days) from the replacement or repair date.
5. ARAG will not recognize any further expressed or intended guarantees, apart from those listed here.  
No representative or retailer is authorized to take on any other responsibility relative to ARAG products.  
The period of the guarantees recognized by law, including the commercial guarantees and allowances for special purposes are limited, in length of time, to the validities given here.  
In no case will ARAG recognize loss of profits, either direct, indirect, special or subsequent to any damage.
6. The parts replaced under guarantee remain the property of ARAG.
7. All safety information present in the sales documents regarding limits in use, performance and product characteristics must be transferred to the end user as a responsibility of the purchaser.
8. Any controversy must be presented to the Reggio Emilia Law Court.

---

**15 END-OF-LIFE DISPOSAL**

---

Dispose of the system in compliance with the established legislation in the country of use.

---

**16 EU DECLARATION OF CONFORMITY**

---

The declaration of conformity is available at the website [www.aragnet.com](http://www.aragnet.com), in the relevant section.

---

*Only use genuine ARAG accessories or spare parts to make sure manufacturer guaranteed safety conditions are maintained in time. Always refer to the Internet address [www.aragnet.com](http://www.aragnet.com).*

06/2022

D20442\_GB-m02



---

42048 RUBIERA (Reggio Emilia) - ITALY

Via Palladio, 5/A

Tel. +39 0522 622011

Fax +39 0522 628944

[www.aragnet.com](http://www.aragnet.com)

[info@aragnet.com](mailto:info@aragnet.com)