

1	GENERAL INFORMATION		6	USE AND OPERATION	
1.1.	PURPOSE OF THE MANUAL.....	3	6.1.	HITCHING TO TRACTOR.....	26
1.2.	MANUFACTURER'S IDENTIFICATION AND EQUIPMENT	4	6.1.1	Front tracker trailed units - hitching to tractor.....	26
1.3.	LIST OF ANNEXES ENCLOSED.....	4	6.1.2	Mounted units - hitching to tractor	28
2	TECHNICAL INFORMATION		6.1.3	Trailled units - hitching to tractor	29
2.1.	GENERAL DESCRIPTION OF THE SPRAYERS.....	5	6.1.4	Removable units - hitching to tractor	31
2.2.	OPERATION DIAGRAMS	6	6.1.5	Cardan shaft coupling (just for TRAILED UNITS, FRONT TRACKER TRAILED UNITS and MOUNTED UNITS).....	32
2.3.	TECHNICAL SPECIFICATIONS	9	6.1.6	Hydraulic connection (if fitted)	34
2.4.	SAFETY DEVICES.....	10	6.2.	PRECAUTIONS TO BE ADOPTED DURING THE TRANSFER WITH HITCHED EQUIPMENT	34
2.5.	SAFETY RATING PLATES - POSITION AND DESCRIPTION	11	6.3.	UNCOUPLING FROM THE TRACTOR	34
2.6.	ATTACHMENTS UPON REQUEST.....	13	6.3.1	Front tracker trailed units - uncoupling from tractor.....	35
3	SAFETY INFORMATION		6.3.2	Mounted units - uncoupling from the tractor	36
3.1.	GENERAL SAFETY REGULATIONS	14	6.3.3	Trailled units - uncoupling from tractor	36
3.2.	HANDLING SAFETY REGULATIONS	14	6.3.4	Removable units - uncoupling from the tractor...	37
3.3.	OPERATION SAFETY REGULATIONS	14	6.4.	DESCRIPTION OF CONTROLS	38
3.4.	ADJUSTMENT AND MAINTENANCE SAFETY REGULATIONS.....	15	6.4.1	Description of the distributor (STANDARD 461)	39
4	HANDLING AND LOADING		6.4.2	Description of the distributor (IDROMINUS).....	40
4.1.	TRANSPORTATION AND PACKAGING	16	6.4.3	Description of the distributor (ELECTRO 461)	42
4.2.	LOADING AND UNLOADING	16	6.5.	TANK FILLING	45
4.3.	CLAMPS OF THE REMOVABLE UNIT - INSTALLATION	17	6.6.	CHEMICAL PRODUCTS HANDLING	46
5	ADJUSTMENT AND SETTING UP		6.7.	CHEMICAL PRODUCT - MIXTURE PREPARATION.....	46
5.1.	DRAWBAR LENGTH - ADJUSTMENT (JUST FOR TRAILED UNITS)	21	6.8.	CHEMICAL PRODUCT SPRAYING.....	50
5.2.	TRACK - ADJUSTMENT.....	22	6.9.	EMPTYING THE TANK FROM THE RESIDUES	51
5.3.	WATER DISTRIBUTOR - POSITION ADJUSTMENT (ONLY FOR TRAILED AND REMOVABLE UNITS)	22	7	EQUIPMENT MAINTENANCE	
5.4.	PRODUCT SPRAYING - PARAMETERS SETTING UP	23	7.1.	DAILY MAINTENANCE	52
5.4.1	Tractor forward speed calculation	24	7.2.	SUCTION FILTER CLEANING.....	54
5.4.2	Nozzles spray check	24	7.3.	ROUTINE MAINTENANCE - EVERY 40 HOURS	55
			7.4.	UNSCHEDULED MAINTENANCE	55
			7.4.1	Equipment functions control devices	56
			7.5.	WINTER STOP.....	56
			8	TROUBLESHOOTING	
			8.1.	TROUBLES, CAUSES, CURES.....	57

GENERAL INFORMATION **1**

368.037

1.1. PURPOSE OF THE MANUAL

Read carefully this manual before servicing the equipment.

This manual has been drafted by the Manufacturer and it is integral part of the equipment.

Tractor operating instructions, as well as safety information, are included here.

Said information is aimed at the professional user (operator), who, in addition to a specific skill relevant to the driving of the tractor on which this equipment is fitted, must also have acquired a certain experience in the field for which this equipment has been designed and manufactured.

Furthermore, a generic mechanical experience and an agricultural mechanics skill are of the utmost importance to allow the user either to fit the equipment or to carry out adjustment and maintenance operations in safe conditions.

 **DANGER-WARNING: it is absolutely forbidden to any user and / or operator to use the equipment for a different aim than the ones it is specifically conceived for.**

This manual defines the purpose for which the equipment has been designed and manufactured and contains all the information necessary to ensure a safe and correct operation.

Some important parts of the text have been highlighted and preceded by the symbols shown and defined below.

 **DANGER-WARNING: it shows an impending danger which might cause serious injury; give it the greatest attention.**

 **CAUTION: it points out situations requiring a particular procedure to avoid accidents or damages to property.**

 **INFORMATION: Important technical information.**

In pursuing a policy of constant development and updating of the product, the manufacturer might introduce changes to the equipment without any prior notice.

Front tracker trailed units

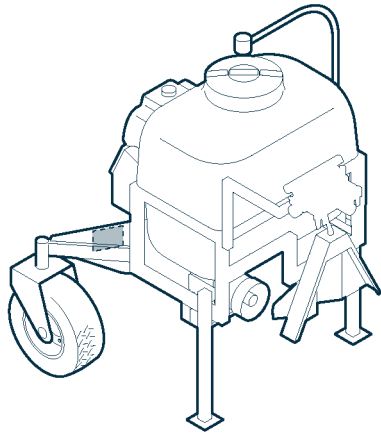

Mounted units

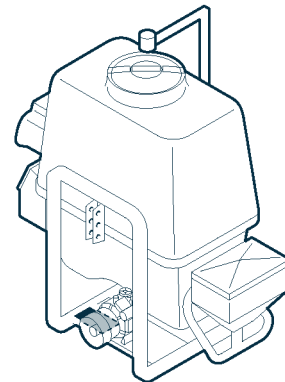

Trailed units

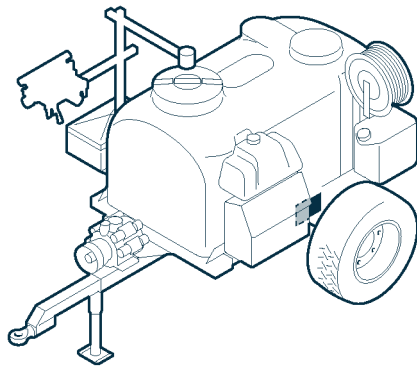

Removable units

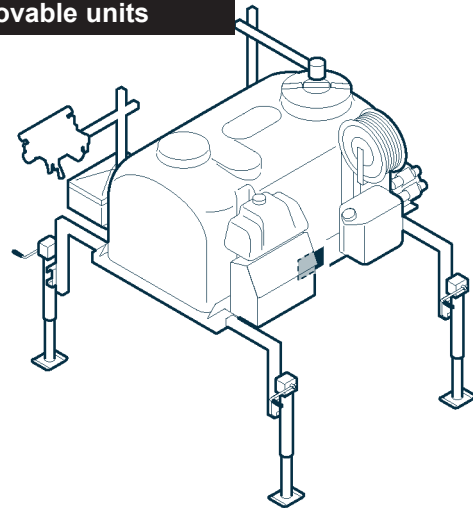

1.2. MANUFACTURER'S IDENTIFICATION AND EQUIPMENT

- A - Manufacturer's identification.
- B - Model.
- C - Serial number.
- D - Dry weight.
- E - Total permitted weight.
- F - Max. pressure.
- G - Year of construction.

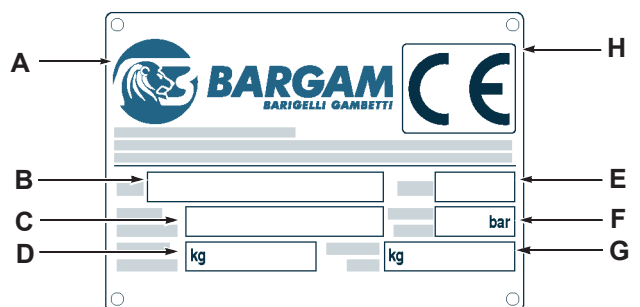

1.3. LIST OF ANNEXES ENCLOSED

Booklets including information about different elements that can be assembled to Your tractor are enclosed.

Even if your tractor is considerably different from pictures shown in this document, safety information is valid in any case.

Annexes enclosed:

- Spraying boom operation manualbooklet F.**

TECHNICAL INFORMATION 2

368.037

2.1. GENERAL DESCRIPTION OF THE SPRAYERS

“AMENITY” is a complete line of sprayers, consisting of equipment engineered and manufactured by assembling several elements in order to meet different operational needs.

The sprayers consist of equipment with diversified characteristics, devised for agricultural use and, in particular, for spraying chemical substances (fertilisers, weed-killers, antiparasitic substances, etc.) on the ground or directly on cultivated products.

This equipment, coupled to the tractor, contains chemical substances to be sprayed. A pump driven by the tractor power take off, through a cardan shaft, directs the product to the spraying boom.

Setting up of the units

The main units forming “AMENITY” equipment are shown in the picture:

- A - Spray product tank.
- B - Pump
- C - Water distributor.
- D - Fresh water container.
- E - Clothes holder (upon request)
- F - Mixer
- G - Blob marking tank (if fitted).
- H - Hose reel (if fitted)
- L - Spraying boom (see booklet F)

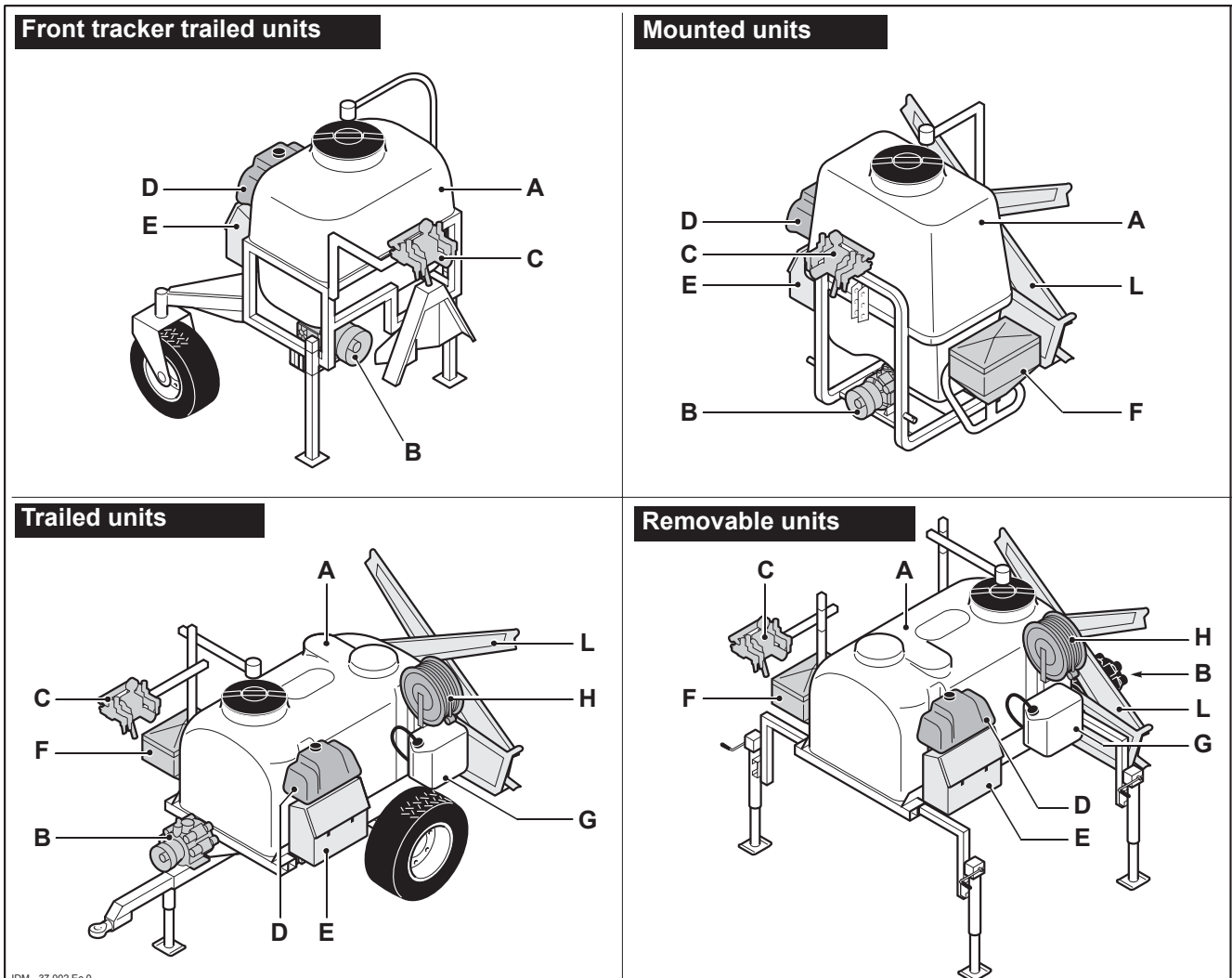

IDM - 37.002 Ec.0

2.2. OPERATION DIAGRAMS

We describe herewith the different types of operation cycles according to the models of sprayers and the types of control units.

De-mountable sprayers with electric control unit

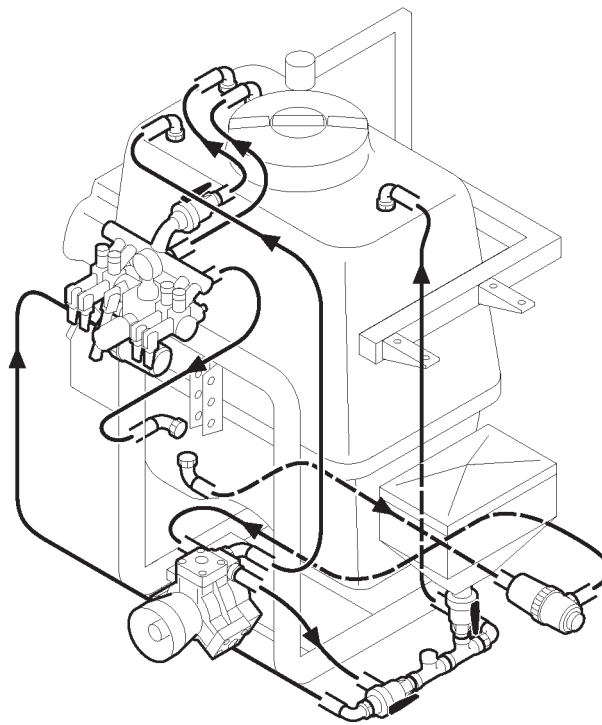

IDM-3680370621.tif

Trailed sprayers with manual control unit

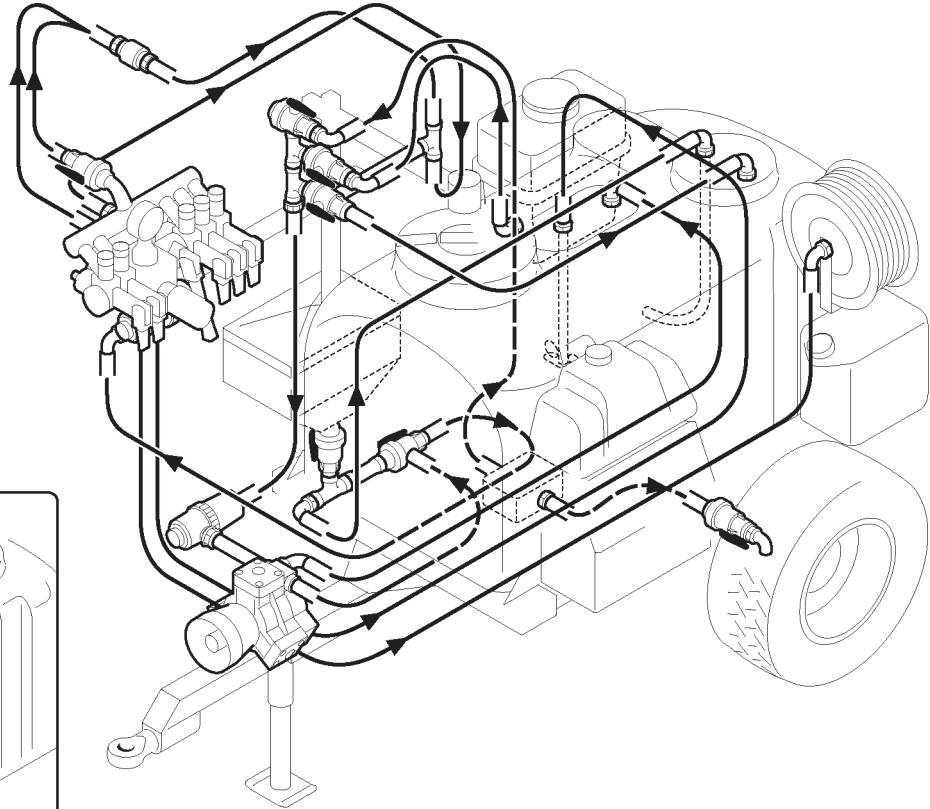

Special mixing with bottom return pipe (on demand)

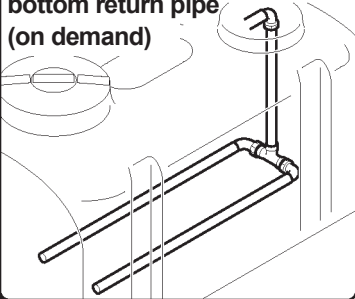

IDM-3680370601.tif

De-mountable sprayers with manual control unit

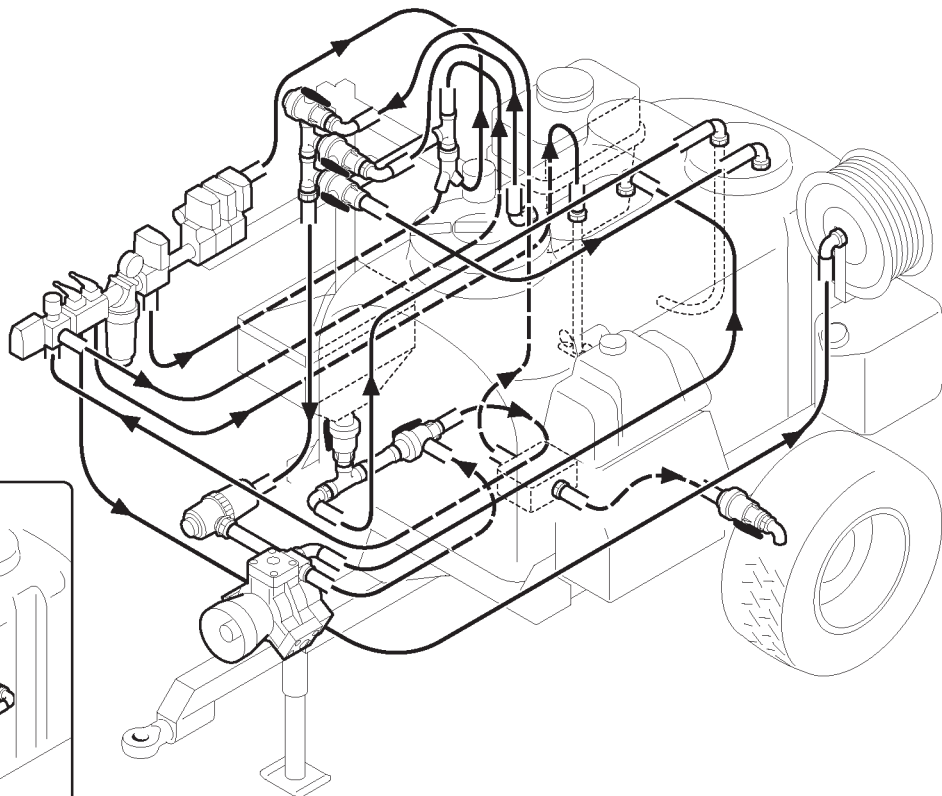

Special mixing with bottom return pipe (on demand)

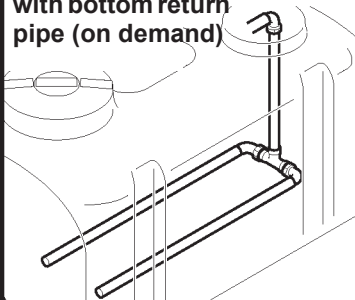

IDM-3680370611.tif

Mounted sprayers with manual control unit

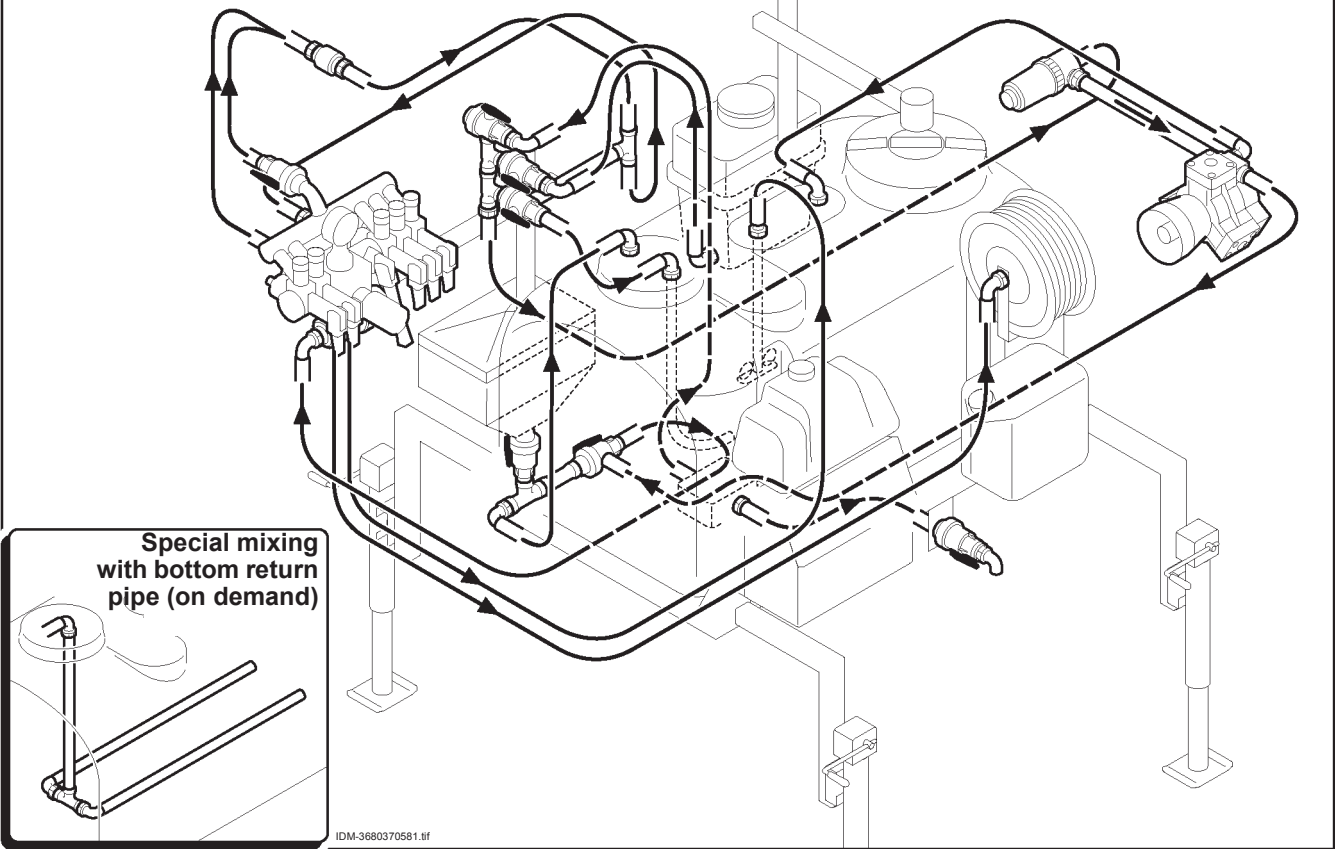

Trailed sprayers with manual control unit

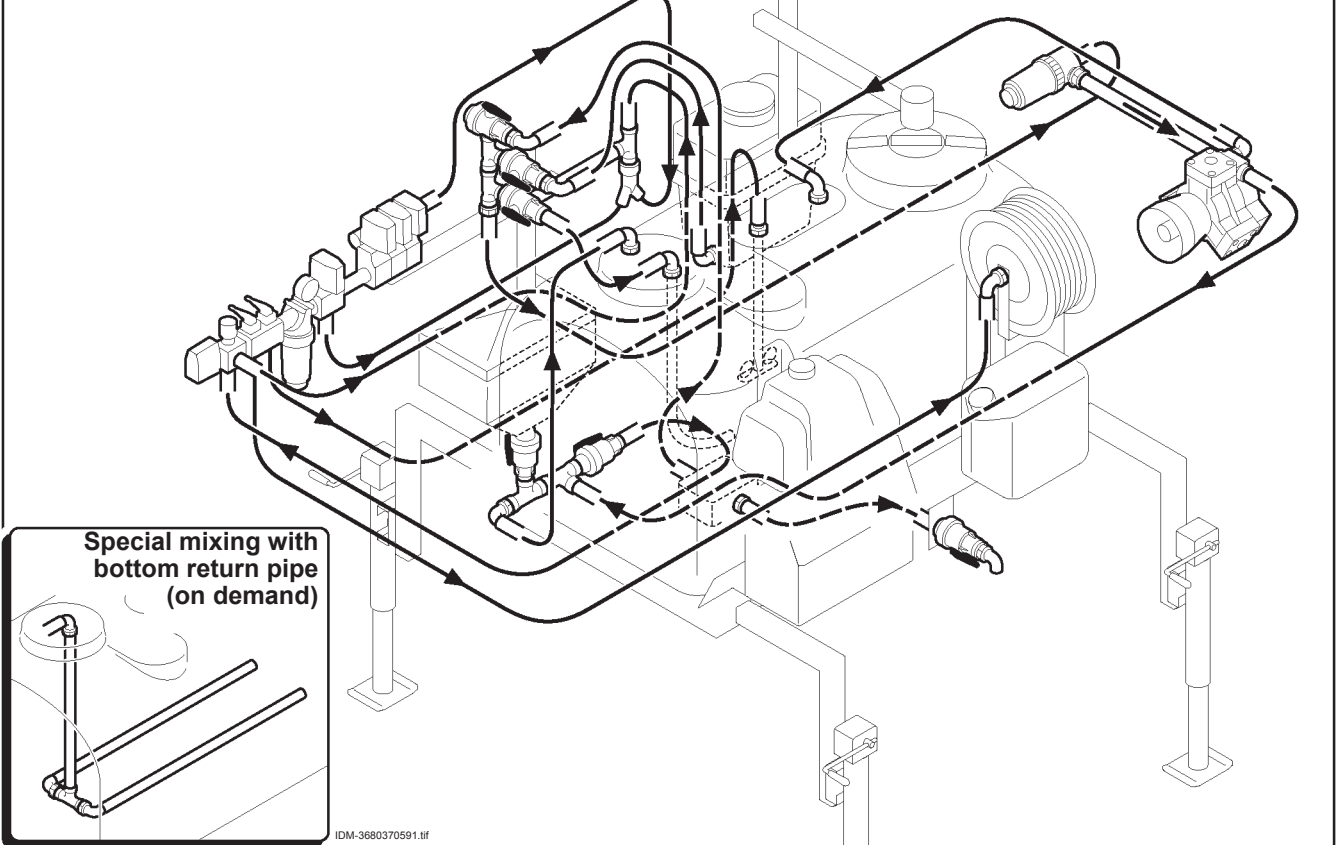

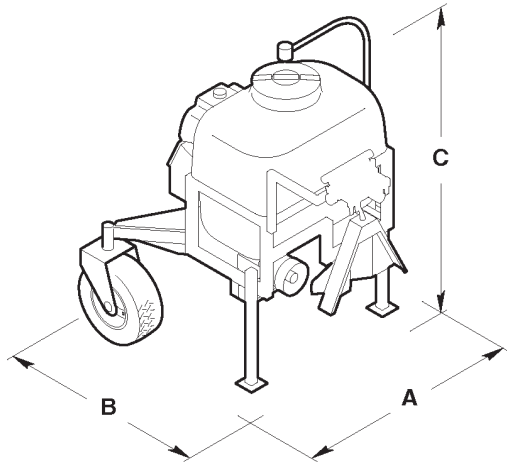
2.3. TECHNICAL SPECIFICATIONS
Front tracker trailed units

Model	Capacity l	A mm	B mm	C mm	kg
SAG 200 Amenty	200	1550	1400	1250	140

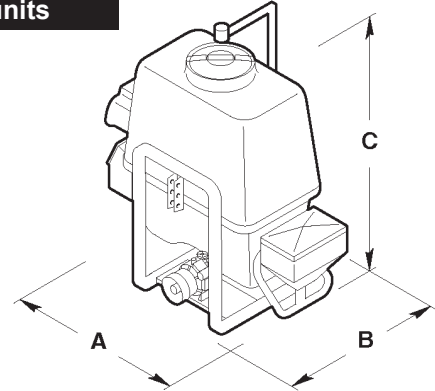
Mounted units

Model	Capacity l	A mm	B mm	C mm	kg
POG 200 Amenty	200	1540	710	1200	89
POG 300 Amenty	300	1540	710	1350	93
POG 400 Amenty	400	1540	710	1550	105
POG 600 Amenty	600	2050	810	1600	161
POG 800 Amenty	800	2455	955	1856	208

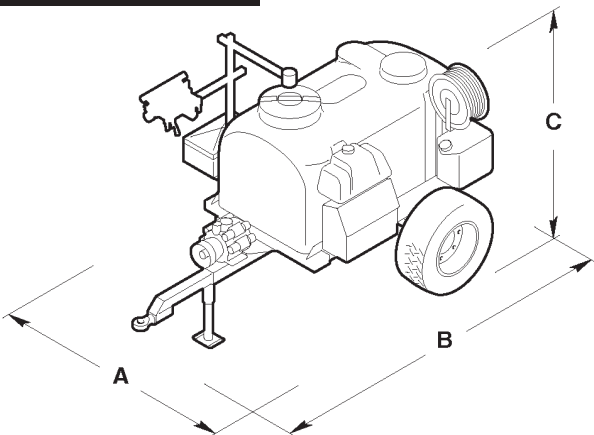
Trailed units

Model	Capacity l	A mm	B mm	C mm	kg
GTG 650 Amenty	600	1350	2630	1315	300
GTG 850 Amenty	800	1350	2630	1280	321

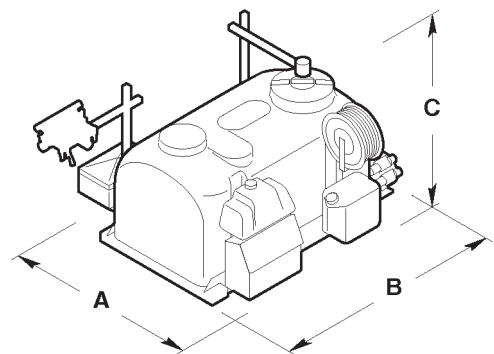
Removable units without feet

Model	Capacity l	A mm	B mm	C mm	kg
GSG 350 Amenty	300	1620	1600	1085	186
GSG 450 Amenty	400	1620	1600	1220	190
GSG 600 Amenty	600	1620	1600	1400	210
GSG 650 Amenty	600	1720	1860	1220	226
GSG 850 Amenty	800	1720	1860	1365	235

Removable units with feet

Model	Capacity l	A mm	B mm	C mm	kg
GSG 350 Amenty	300	2080	1650	1215	186
GSG 450 Amenty	400	2080	1650	1350	190
GSG 600 Amenty	600	2080	1650	1530	210
GSG 650 Amenty	600	2180	1910	1350	226
GSG 850 Amenty	800	2180	1910	1495	235

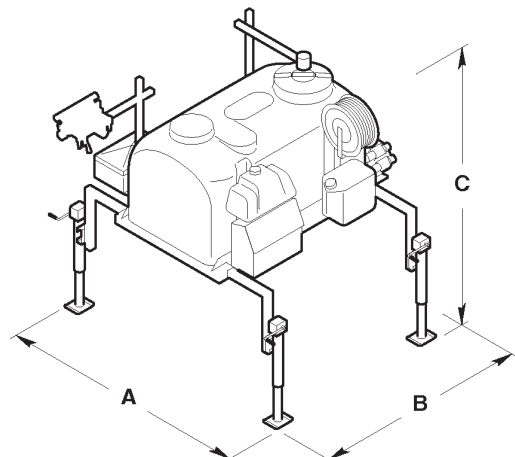

□ **Technical residue**

The volume of the liquid which can not be correctly distributed does not exceed 0.5% of the nominal volume plus 2 litres per boom meter.

Model	nominal cap. (l)	Residual volume (l)		
		soluble	not soluble	total
GSG350 Amenity	300	10	3,4	13,4
GSG450 Amenity	400	10	3,4	13,4
GSG600 Amenity	600	10	3,4	13,4
GSG650 Amenity	600	11,4	3,5	14,9
GSG850 Amenity	800	11,4	3,5	14,9

Note: data in the table refer to equipment with 6m booms.

2.4. SAFETY DEVICES

A - Fixed guard; cardan transmission protection.

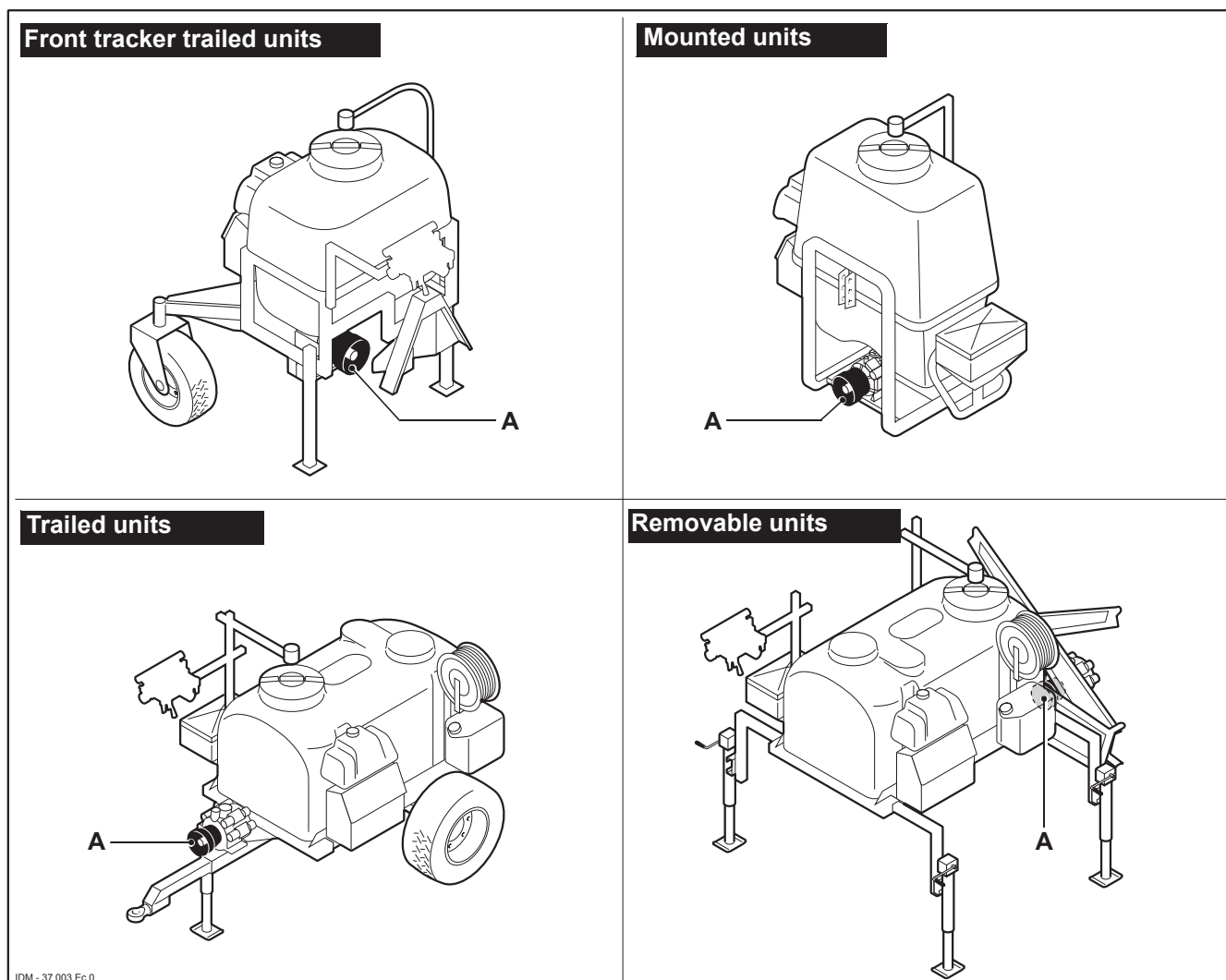

IDM - 37.003 Ec.0

2.5. SAFETY RATING PLATES - POSITION AND DESCRIPTION

i **INFORMATION:** Make sure all the rating plates are clear, otherwise replace them and position them exactly in the same point.



1 A- Danger of arms crushing. Give the greatest attention during the hooking to the tractor height adjustment.



2 B- Generic danger. Turn off the tractor and read the operation manual before carrying out any servicing whatsoever.



4 C- Read this manual. The operator using the equipment must read this manual to know the position and controls function and learn all the information contained herein. The manual must always be kept within reach.



5 D- Always wear gloves. To be used whenever handling products.



6 E- Wear a gas-mask. To be worn whenever handling and using chemical products.

Front tracker trailed units

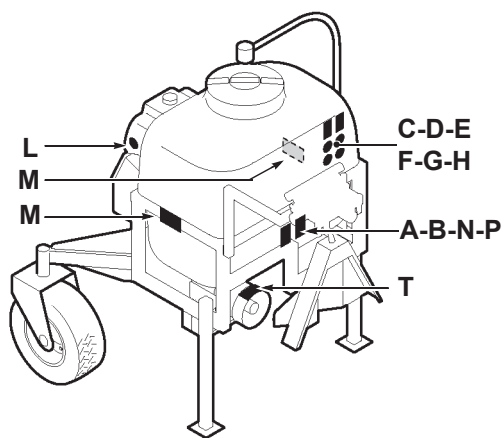

Mounted units

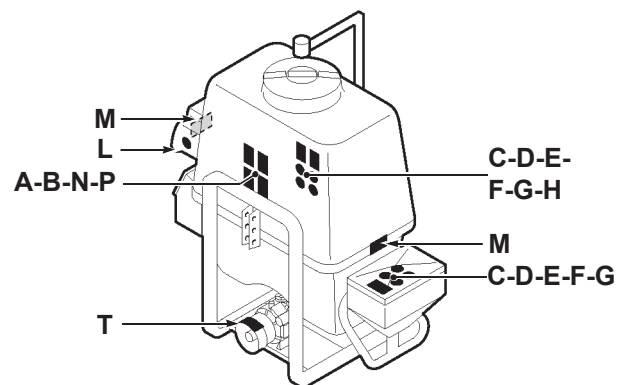

Trailed units

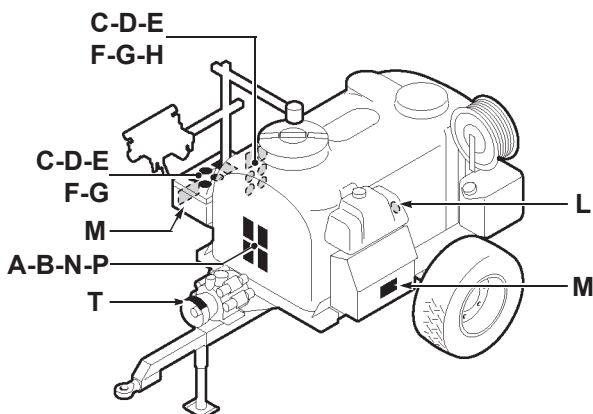

Removable units

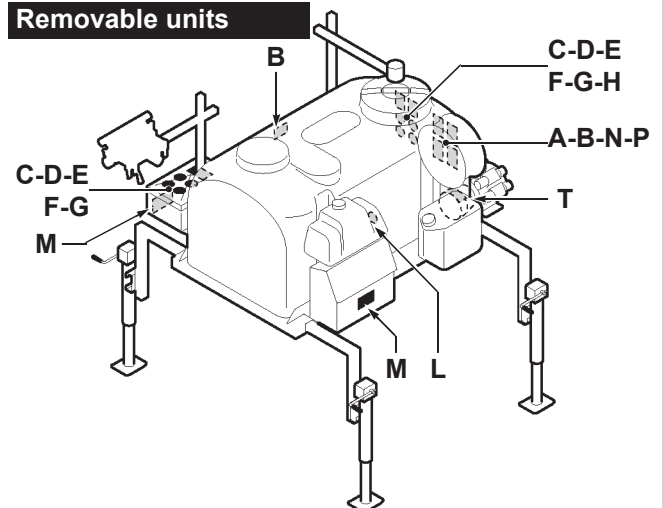



7 F - Wear protective clothes. To be worn whenever handling and using chemical products.



8 G - Arms corrosion danger. Give the greatest attention whenever handling chemical products. Always wear gloves.



8 H - General danger. Warning: do not introduce any parts of your body into the tank.



10 L - Always use clean water. Always wash hands when handling chemical products.



15 M - Do not pass. Non-authorized people are not allowed to stand or pass within the machine range.



N - Warning: general danger. Do not use pressure exceeding 20 bars.



P - Warning: danger of pressurised oil leaks. Read the instruction manual before carrying out any maintenance operations on the machine.



T - general danger. Before fitting in the cardan shaft, check the direction of rotation and number of revolutions of the power takeoff.

2.6. ATTACHMENTS UPON REQUEST

The attachments that can be installed on “AMENITY” equipment are listed and described below.

The attachments that can be installed on different models of equipment are listed in the table.

<i>Attachment</i>	<i>Front tracker trailed units</i>	<i>Mounted units</i>	<i>Trailed units</i>	<i>Removable units</i>
Mixer kit		•	•	• (*)
System washing kit		•	•	•
Foam marker kit		•	•	•
Hose reel kit		•	•	•
Special mixing kit		•	•	•
Electric distributor	•	•	•	•

(*) Current accessories for units with 650 and 850-litre tanks.

Mixer kit

It mixes chemical substances with water inside the tank.

System washing kit

To wash the fluid distribution ducts at the end of the working cycle.

Foam marker kit

It consists of an air compressor, a blob marking tank and two sprayers fitted on the spraying boom end. Whenever this device is operating, foam blobs fall on the ground, thus marking the ground already sprayed.

Hose reel kit

It allows to reel the hose used for the attachment “nozzle”.

Special mixing kit

Enables to keep the liquid agitated in the tank during spraying in order to avoid any product settling.

Electric distributor

It is equipped with electric motors for valve opening and closing; it is also equipped with a control board that can be positioned in the tractor driver’s cabin.

3.1. GENERAL SAFETY REGULATIONS



Read carefully this operation and maintenance instruction manual before carrying out any installation, starting, operation, adjustment or maintenance, etc.

- Said equipment requires the use and handling of chemical substances, thus making the knowledge of these products necessary to avoid damages to people and environment. All the instructions supplied by the Manufacturer of said substances must be duly complied with.
- As far as the user's safety is concerned, always wear the personal safety clothes and devices to prevent the products from being breathed and avoid any contact with the body.
- *Danger, do not dispose of the residues in the environment:*
- *fluids and/or chemicals residues must be disposed of in accordance with the law in force.*
- *The Manufacturer declines any liability whatsoever for damages to people, animals or property should the safety regulations fail to be complied with.*
- *The operator shall not use the tractor when taking drugs, alcohol or narcotics, which might cause side effects, thus reducing his concentration.*
- *Read carefully the rating plates fixed on the equipment or other parts and make sure to observe the relevant instructions.*

3.2. HANDLING SAFETY REGULATIONS

- *Lifting and handling operations must be carried out through suitable means and by skilled personnel.*
- *Do not stand under suspended loads.*

3.3. OPERATION SAFETY REGULATIONS

- *Do not use controls or hoses as a grip.*
- *Do not leave the tractor and the equipment unattended, unless all safety devices the manufacturer supplied at this purpose have been activated.*
- *Do not allow people (particularly children and handicapped people) to approach the tractor especially during its running.*
- *Do not operate it if guards and protections have been removed or deactivated.*
- *Do not work if the safety devices have not been activated or fail to work properly.*
- *Do not use the equipment as a means of transport or towing.*
- *As far as road circulation is concerned, the equipment must be supplied with the safety devices in compliance with the Motor Vehicle Regulation in force in the user's country.*
- *The user and/or operator shall not use the equipment for purposes differing from those determined by the manufacturer.*
- *Do not use the tractor and the equipment on gradients greater than those determined by the manufacturer.*
- *Make sure to mark all tools used to prepare the chemical products and do not use them for other purposes.*
- *Always wear overalls, gloves, boots, helmet, a mask protecting from dust, and goggles.*

3.4. ADJUSTMENT AND MAINTENANCE SAFETY REGULATIONS

- *Non-authorized personnel shall not be allowed to carry out repairs or maintenance or any other servicing operation.*
- *Unscheduled maintenance and repairs must be carried out in well equipped workshops.*
- *Any change introduced either on the tractor or equipment must be previously authorised in writing by the manufacturer.*
- *Remove dangling clothes which might entangle into the **running parts**.*
- *Before carrying out any cleaning, maintenance or repair, the operator must make sure to activate the safety devices, turn off the tractor engine, remove the ignition key, taking it with him.*
- *Do not enter for any reason whatsoever into the tank.*
- *Should it be necessary to replace parts, always ask for **original spare parts***

HANDLING AND LOADING 4

388.037

4.1. TRANSPORTATION AND PACKAGING

The equipment can be shipped by road, train or ship. Whatever the solution, the equipment is always unpacked.

4.2. LOADING AND UNLOADING

⚠ DANGER-WARNING: Lifting and handling operations must be carried out through suitable means and by skilled personnel.

- Use a lifting hook of a suitable capacity or a fork lift device as shown in figure.
- Slowly lift and handle the equipment avoiding oscillations.

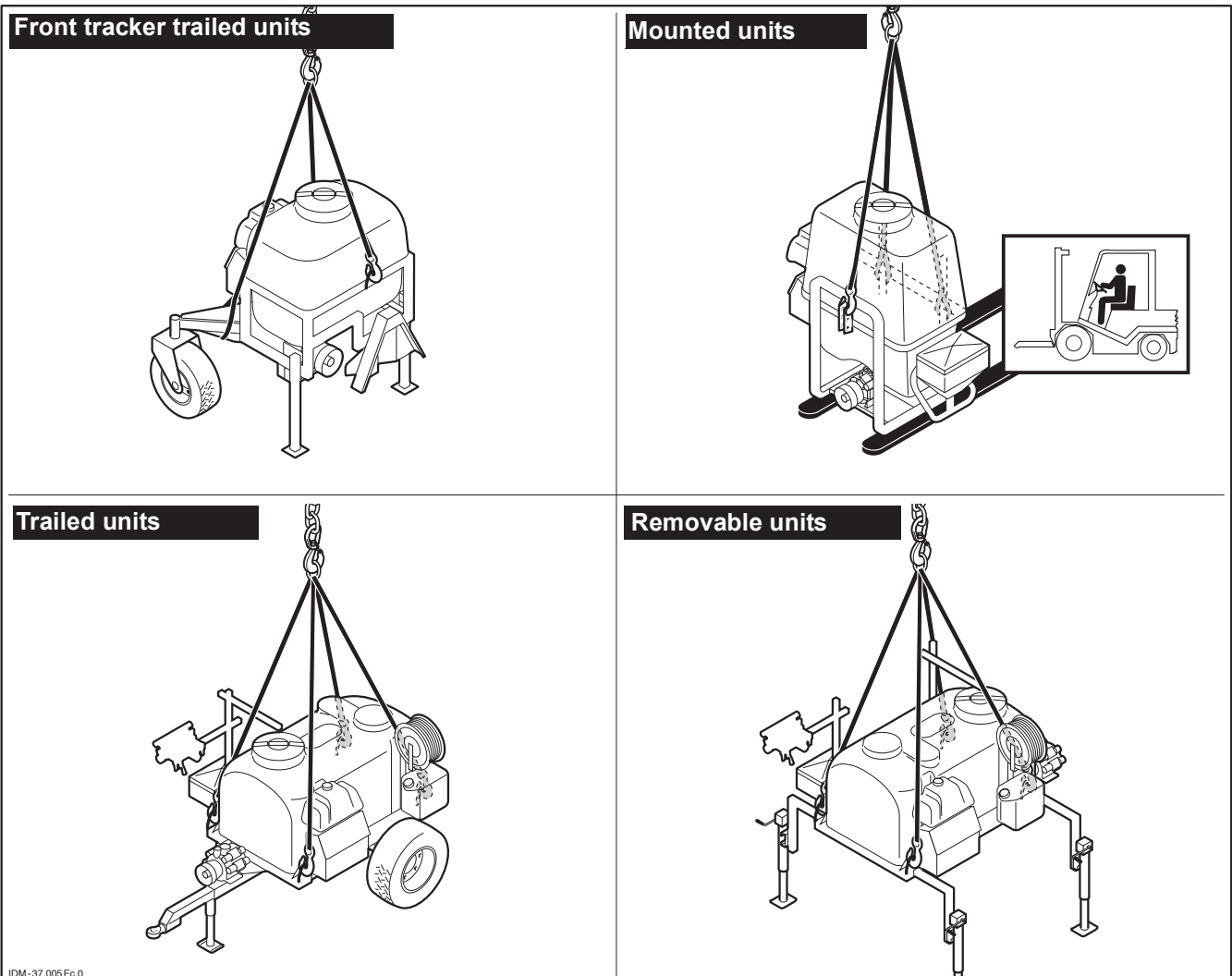

IDM-37.005 Ec.0

4.3. CLAMPS OF THE REMOVABLE UNIT - INSTALLATION

Gambettibarre supplies clamps together with the removable unit, in order to install them on the specific means of transport.

Further on you will find the assembly diagrams of the clamps related to the following means of transport:

- TORO LONG
- TORO SCHORT
- CUSHMAN
- JACOBSEN

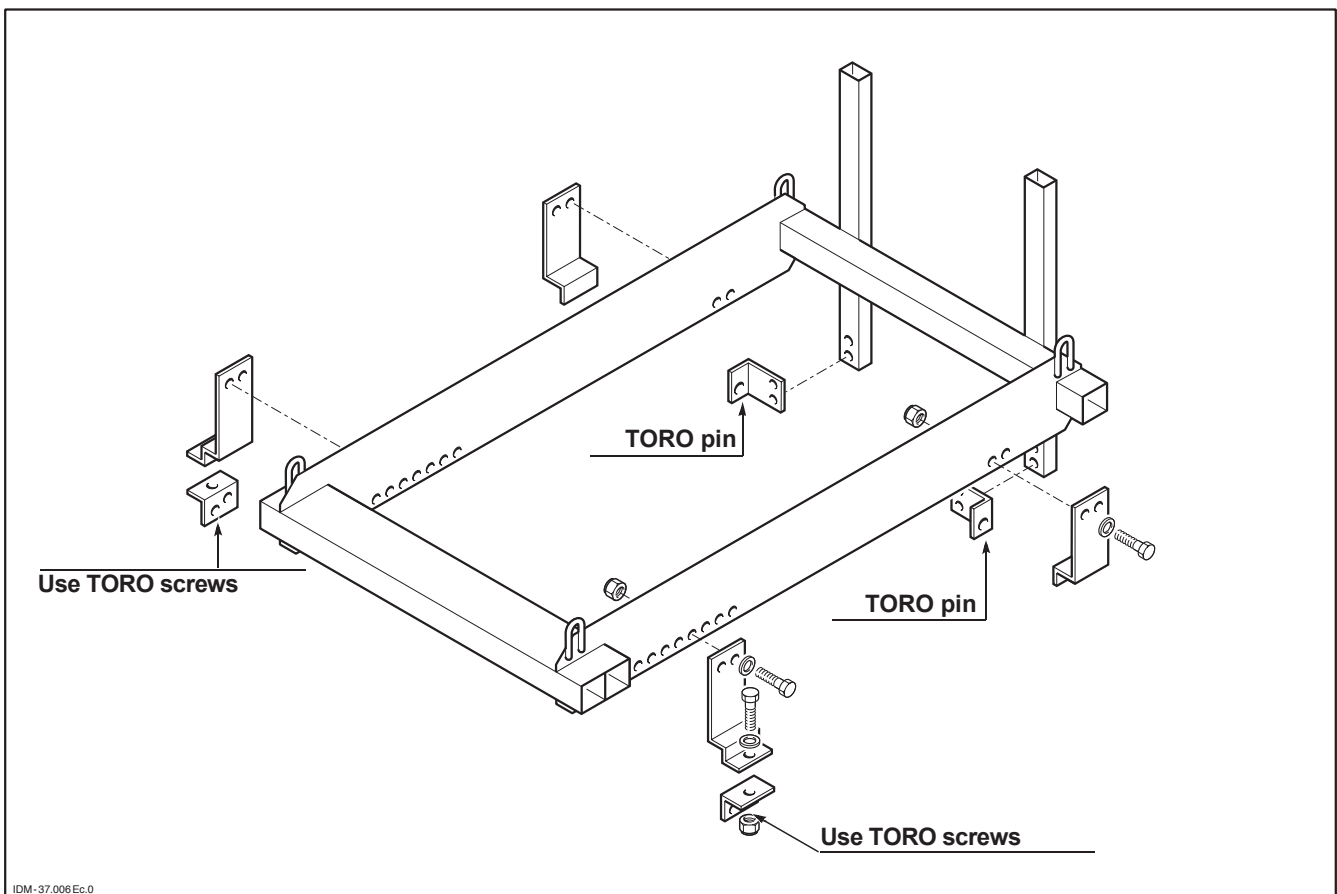

□ Clamp installation for Toro LongClamp installation for Toro SCHORT

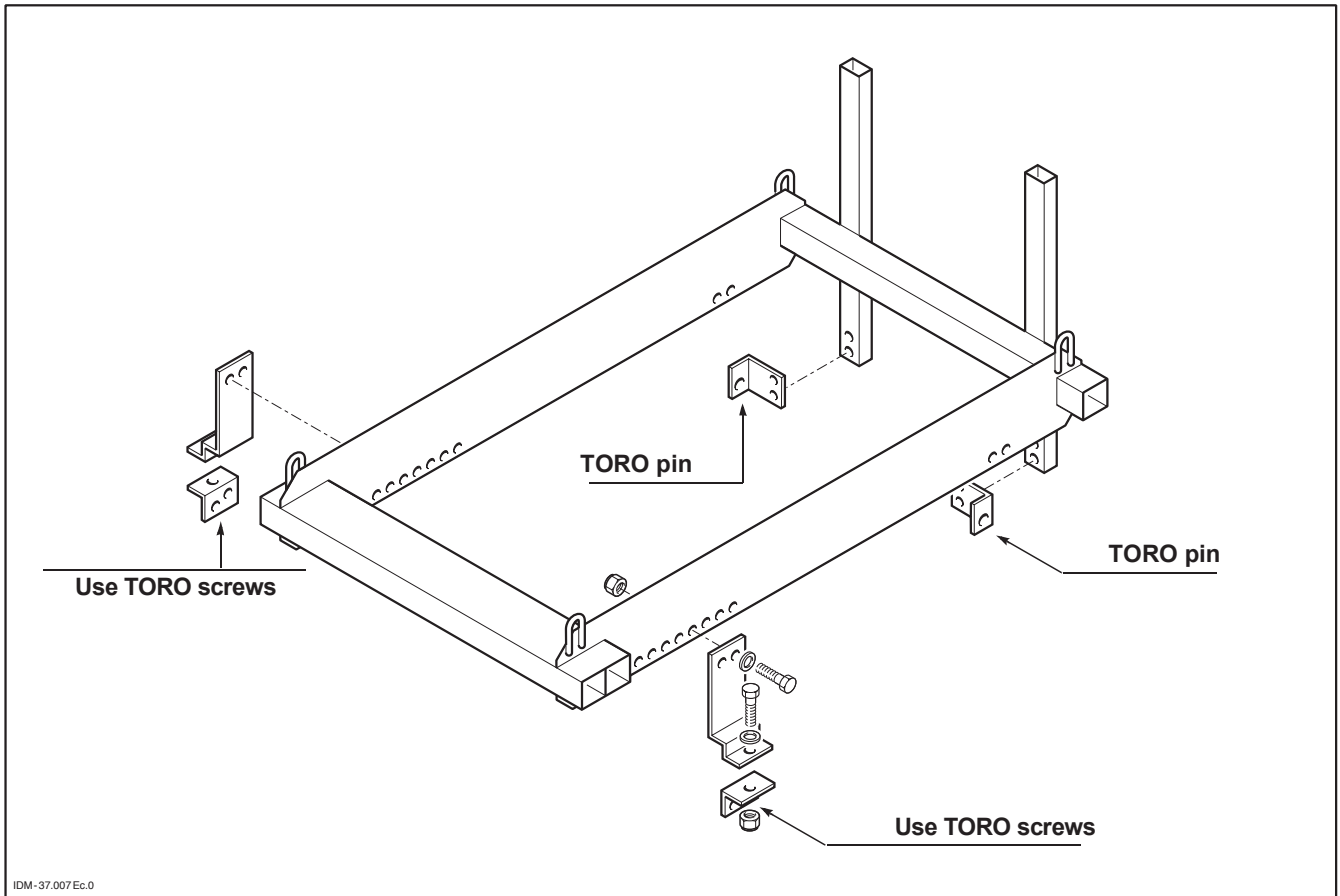

□ Clamp installation for CUSHMAN

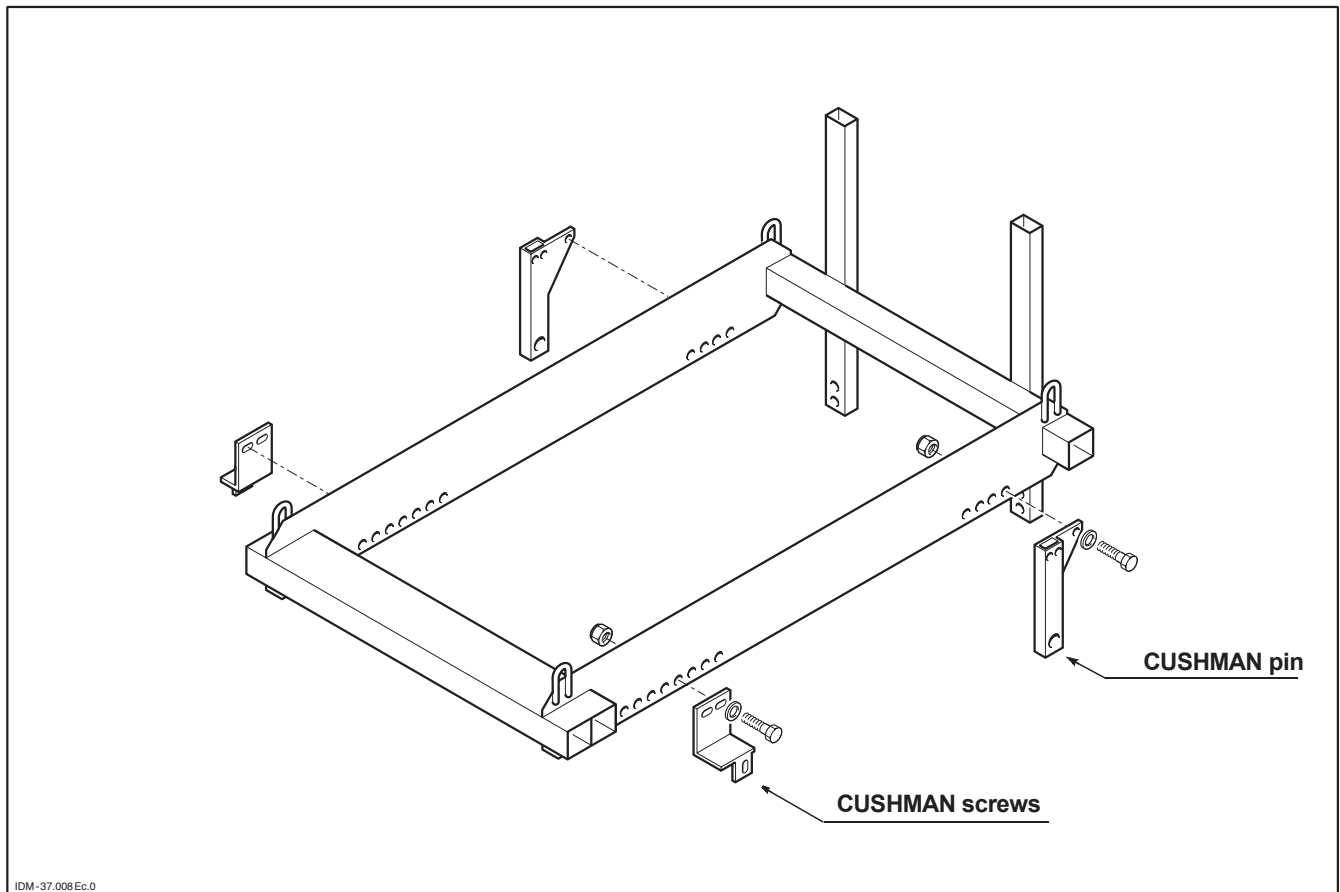

□ **Clamp installation for JACOBSEN**

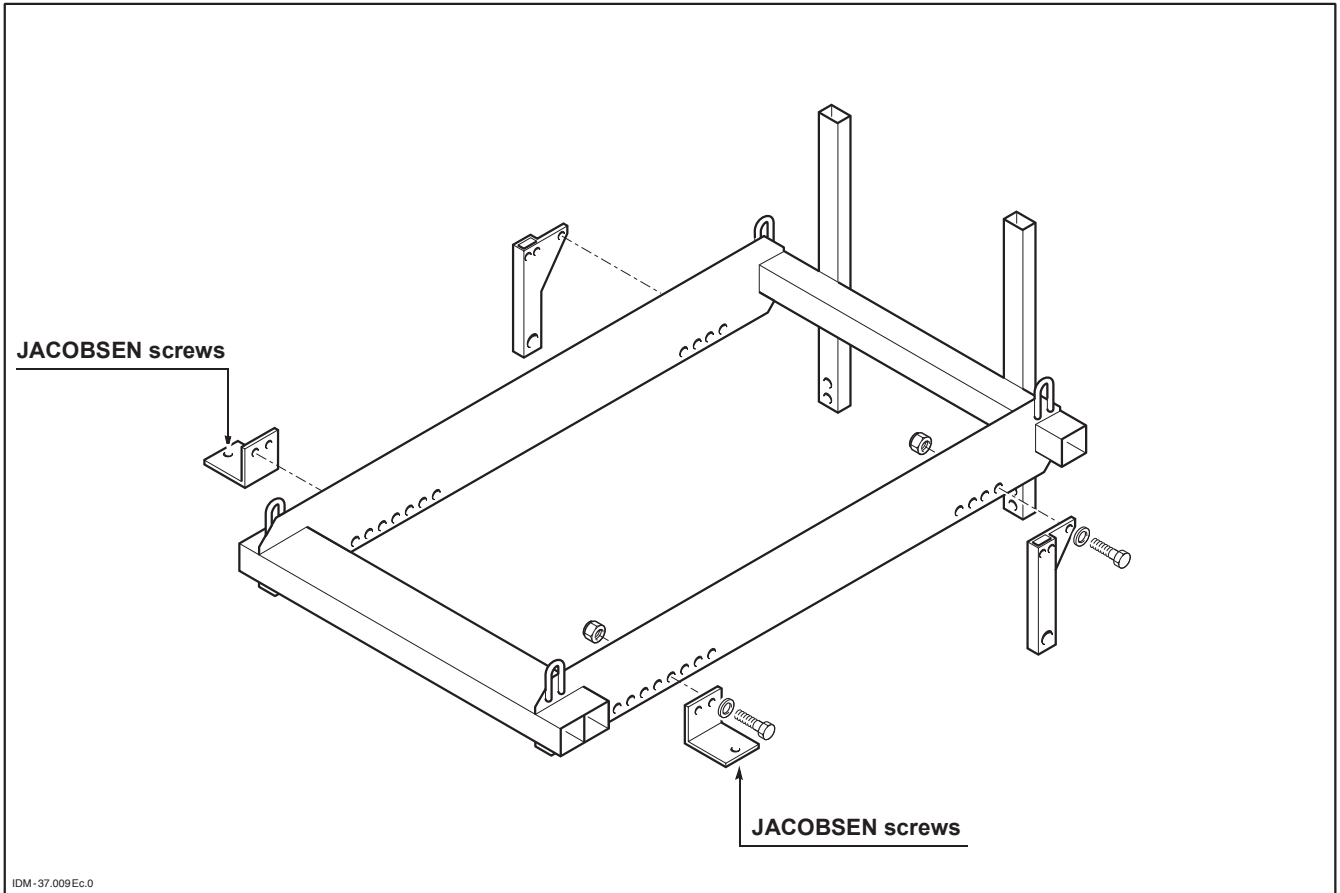

□ **Clamp installation for JD ProGator Short**

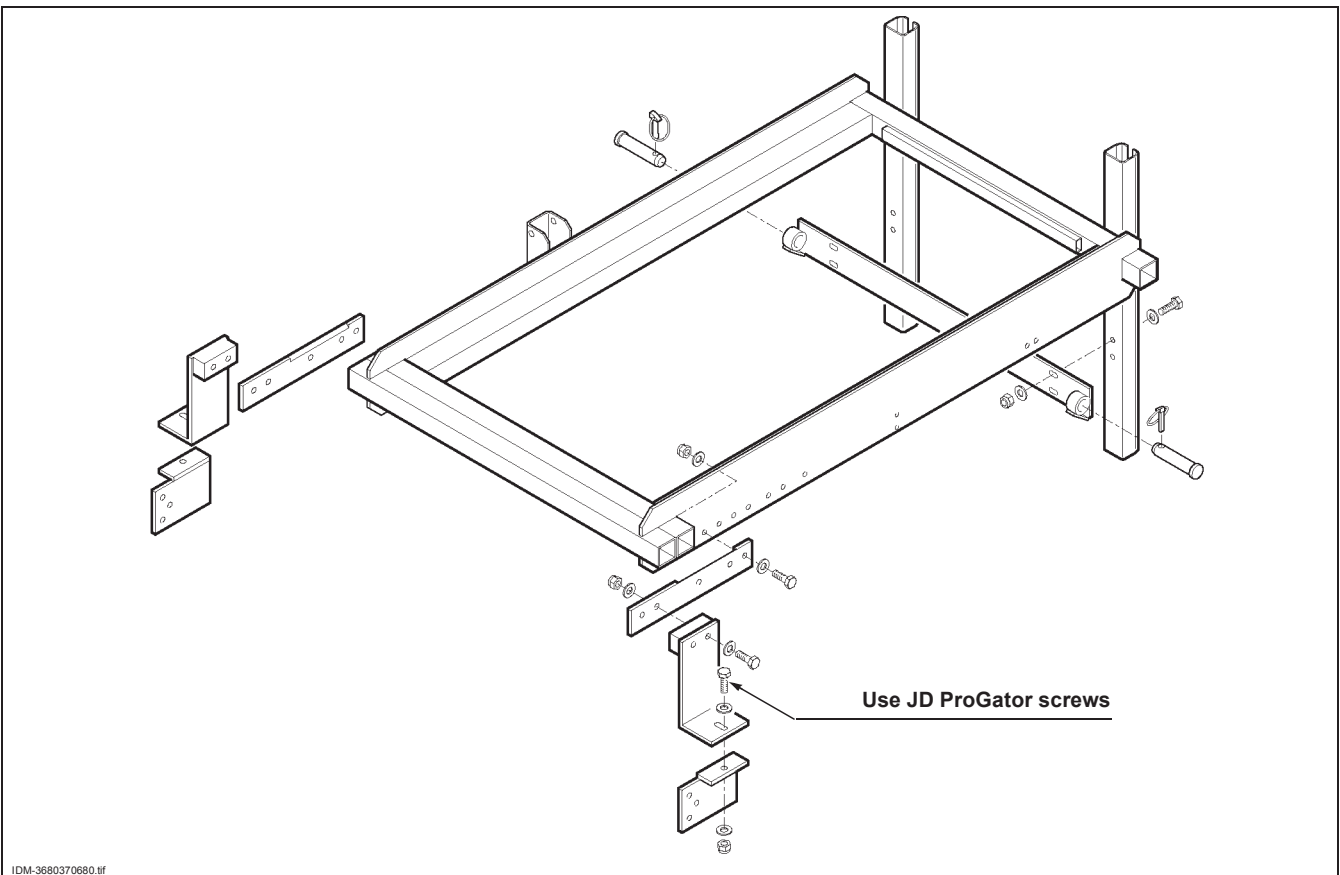

□ Clamp installation for JD ProGator Long

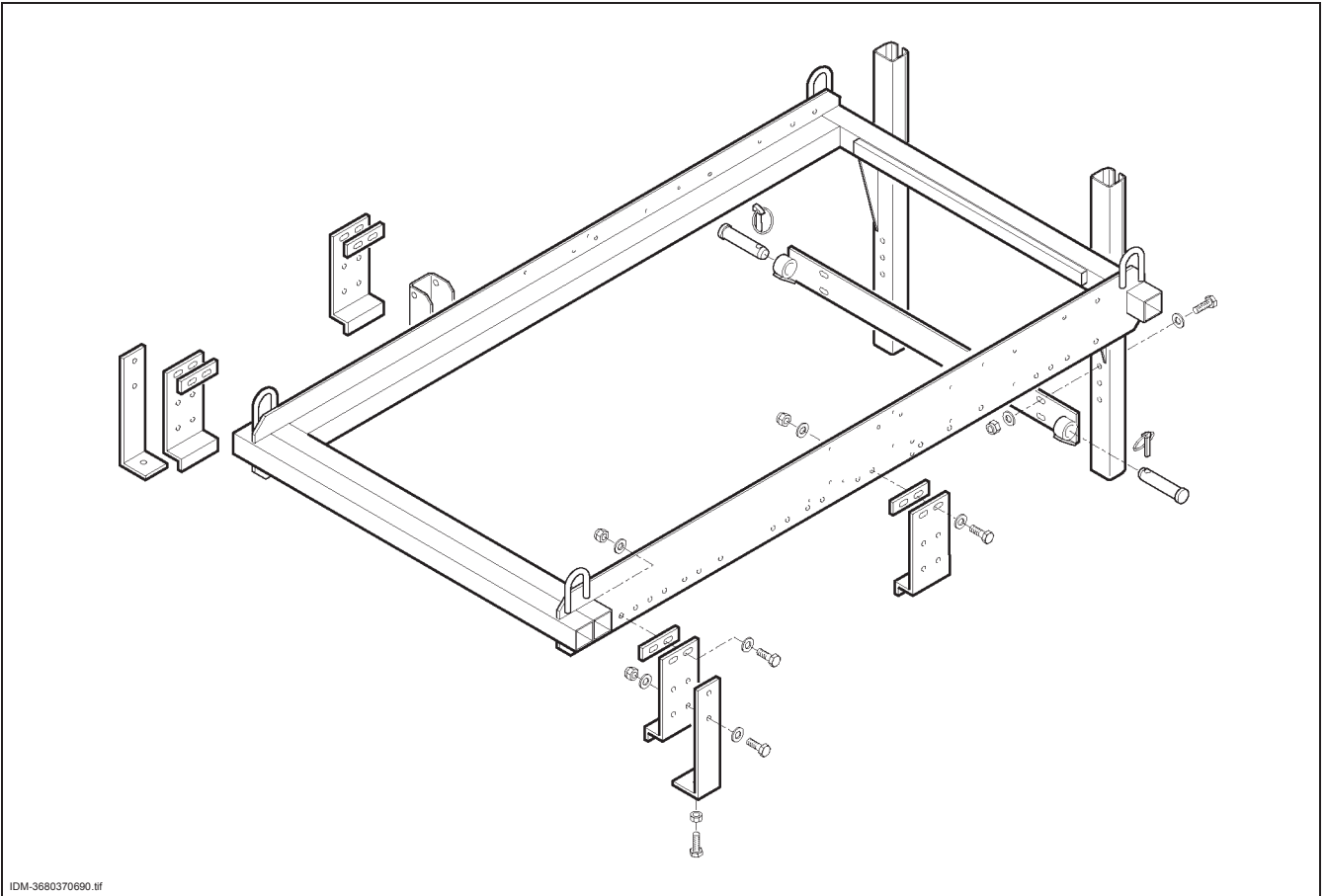

ADJUSTMENT AND SETTING UP 5

368.037

5.1. DRAWBAR LENGTH - ADJUSTMENT (just for TRAILED UNITS)

□ Length adjustment

The drawbar can be adjusted at three lengths, proceeding as shown below.



CAUTION: this operation has to be carried out on flat ground, after locking trailed tank frame and wheels, as shown in the figure.

- Unscrew and take screws **A** out.
- Loosen screws **B**.
- Move drawbar **C** in the position you want, aligning the holes.
- Fit screws **A**, and tighten them with their respective nuts.
- Tighten screws and lock nuts **B**.

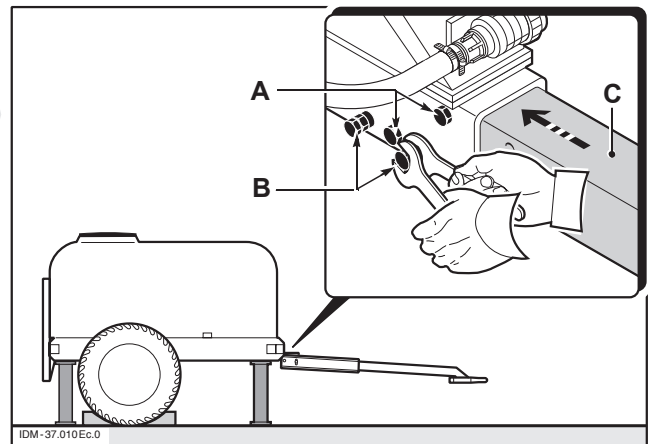

□ Height Adjustment

- Loosen screws **A**, **B** and **C**.
- Put the drawbar at the height you want.
- Tighten screws **A** and **B**.
- Screw tight screw **C** and tighten its respective lock nut.

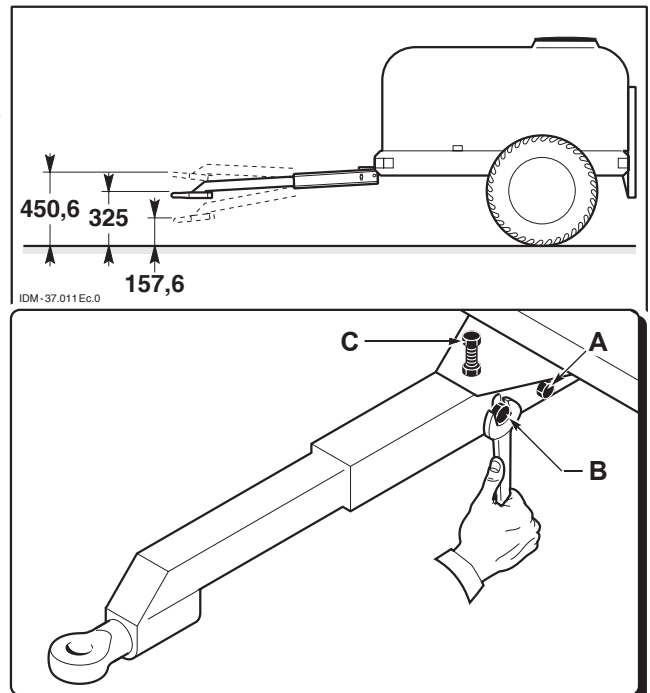

5.2. TRACK - ADJUSTMENT

⚠ DANGER-WARNING: This operation must be carried out on flat ground after the equipment has been hitched to the tractor, the parking brake engaged and the tank emptied.

- Slightly lift the axle using a suitable lifting device.
- Loose bolts **A** and adjust the track into the position required, without exceeding the max. extension measure (270 mm).
- Tighten bolts **A**.
- Carry out the same operation on the opposite wheel.

⚠ CAUTION: After the first kilometre has been covered with the equipment hitched, make sure bolts (A) and lock nuts have been properly tightened.

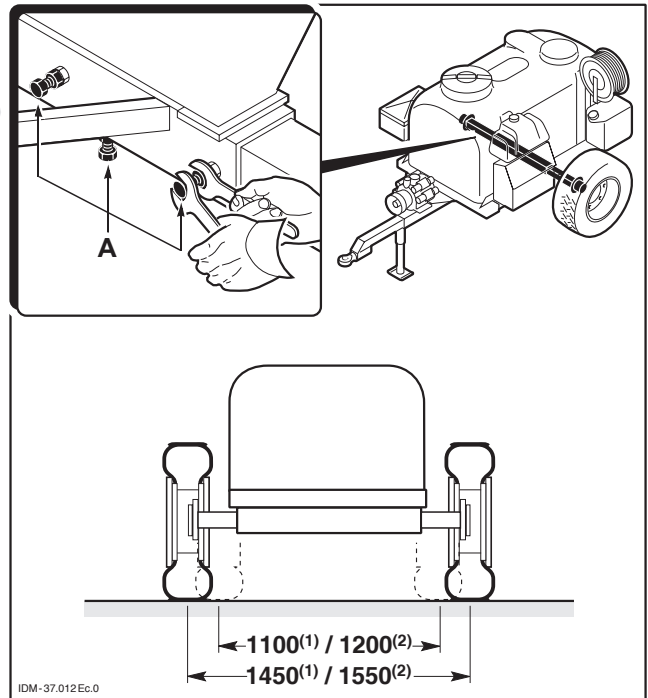

Legend:

- (1) Minimum and maximum tracks for 650-litre units.
- (2) Minimum and maximum tracks for 850-litre units.

5.3. WATER DISTRIBUTOR - POSITION ADJUSTMENT (only for TRAILED and REMOVABLE UNITS)

- Loosen knobs **A**, **B** (**C** only in removable units) and adjust the distributor position.
- Once the distributor position has been adjusted, tighten the knobs.

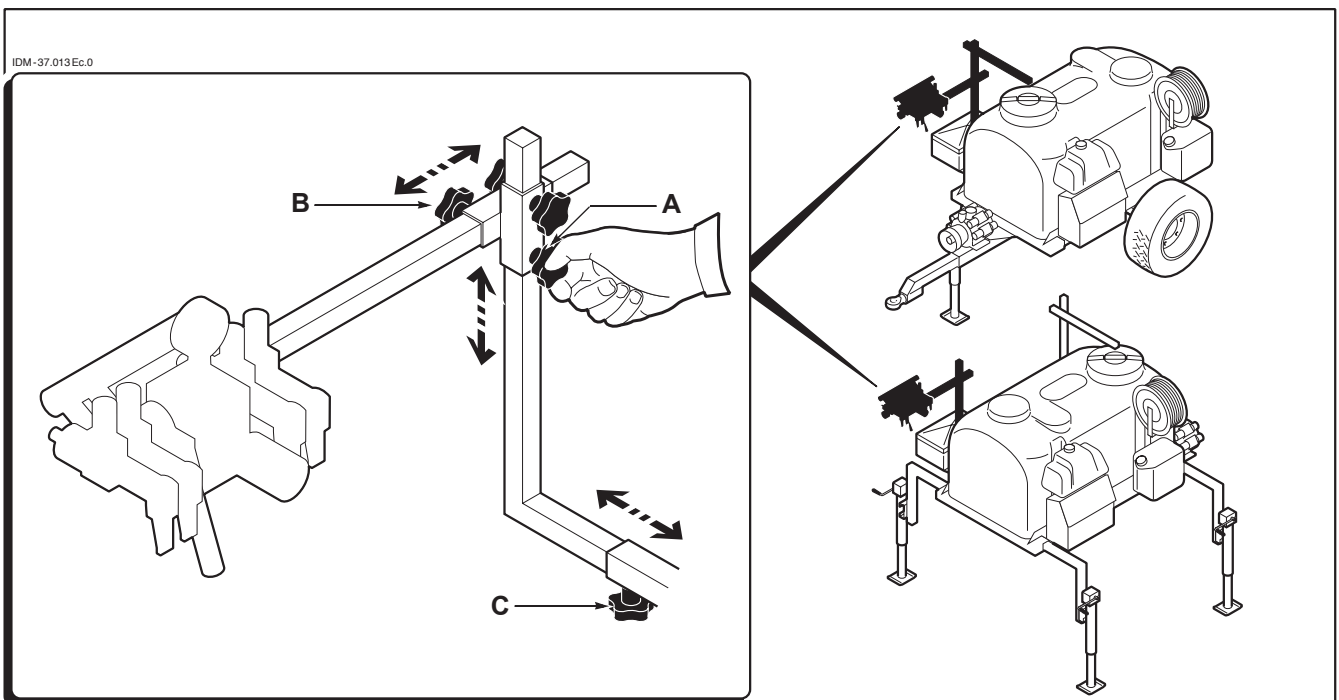

5.4. PRODUCT SPRAYING - PARAMETERS SETTING UP

Parameters must be set in accordance with the tractor forward speed, (to be chosen according to the ground conditions), the quantity of litres per hectare of product to be sprayed (always follow the instructions printed on the product label) and in accordance with the kind of nozzle to be used.

The working pressure can be obtained through the following parameters of the distribution table fitted on the tank.

The only purpose of said table is to provide the user with a consulting example as far as the search of the values is concerned.

□ Distribution table

	ISO	bar	l/min	4 km/h	5 km/h	6 km/h	7 km/h	8 km/h	9 km/h	10 km/h	12 km/h	14 km/h	16 km/h	18 km/h	20 km/h
Yellow	11002	1,5	0,56	168	134	112	96	84	75	67	56	48	42	37	34
		2	0,66	198	158	132	113	99	88	79	66	57	50	44	40
		3	0,8	240	192	160	137	120	107	96	80	69	60	53	48
		4	0,91	273	218	182	156	137	121	109	91	78	68	61	55
		5	1,02	306	245	204	175	153	136	122	102	87	77	68	61
Blue	11003	1,5	0,85	255	204	170	146	128	113	102	85	73	64	57	51
		2	0,98	294	235	196	168	147	131	118	98	84	74	65	59
		3	1,2	360	288	240	206	180	160	120	120	103	90	80	72
		4	1,39	417	334	278	238	209	185	139	139	119	104	93	83
		5	1,55	465	372	310	268	233	207	155	155	133	116	103	93
Red	11004	1,5	1,13	339	271	226	194	170	151	136	113	97	85	75	68
		2	1,31	393	314	262	225	197	175	157	131	112	98	87	79
		3	1,6	480	384	320	274	240	213	192	160	137	120	107	96
		4	1,85	555	444	370	317	278	247	222	185	159	139	123	111
		5	2,07	621	497	414	355	311	276	248	207	177	155	138	124

Values search example

Quantity to be sprayed shown
 on the product label..... 151 l per hectare (l/ha)
 Forward speed9 km/h
 Nozzle 11004 red type nozzle

By searching these values (see the highlighted area in the table), the correct pressure will be thus obtained. In this case, it is of 1.5 bar.

 **CAUTION: Working pressure must range between 1.5 and 5 bar.**

Should the pressure value obtained from the table differ from the above mentioned pressure value, change the forward speed value or the type of nozzle.

To make sure the adjustment has been performed properly, carry out a test by spraying clean water.

5.4.1 Tractor forward speed calculation

Should the tractor fail to be supplied with an odometer, the forward speed must be calculated as follows:

- set the correct forward speed, according to the tractor engine rpm, by covering a known distance;
- cover a hundred metres run previously plotted, keep-

ing the engine number of revolutions steady and measuring the time it took in seconds

- see the speed control table to obtain the forward speed according to the time it took.

□ Speed control table

SPEED (km/h)	4	5	6	7	8	10	12
TIME x 100 m (sec)	90	72	60	51	45	36	30

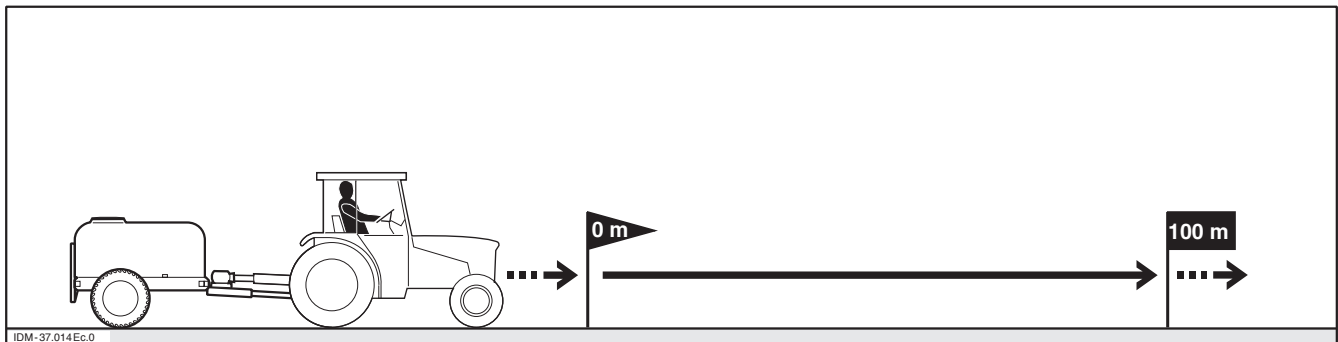

5.4.2 Nozzles spray check

Once the product spray parameters have been set, make sure the quantity value relevant to the sprayed product is the same as the value shown in the table.

□ Check of each nozzle spraying (l/min)

- Position a measuring container under a nozzle working with clean water, at a pressure previously set, for exactly one minute.
- Make sure the quantity of water thus collected is the same as the value shown in the table.
- Carry out this operation on three or four nozzles.

□ Check of the spraying of litres per hectare (l/ha)

- This check must be carried out through a spraying test with clean water on an area of ground hundred meters long, following the procedure below:
- set the forward speed and working pressure values as described in § 5.4.; re-fill the tank;
- spray water with the boom unfolded on a hundred meters distance;
- re-fill the tank, measuring the litres of water which have already been sprayed;
- check on the table relevant to the spraying test carried out on a hundred meters, that the value relevant to product quantity to be sprayed (ex.: 200 l/ha) and the boom length (ex. 10 m) corresponds to the litres of water already sprayed.

□ Table relevant to the spraying test carried out on a hundred meters

Quantity of product to be sprayed in l/ha	boom length (m)												
	6	8	10	12	12,5	14	15	16	18	20	21	24	
100	6	8	10	12	12,5	14	15	16	18	20	21	24	litresx100 m
150	9	12	15	18	18,7	21	22,5	24	27	30	31,5	36	
200	12	16	20	24	25	28	30	32	36	40	42	48	
300	18	24	30	36	37,5	42	45	48	54	60	63	72	
400	24	32	40	48	50	56	60	64	72	80	84	96	
500	30	40	50	60	62,5	70	75	80	90	100	105	120	
600	36	48	60	72	75	84	90	96	108	120	126	144	

To obtain more precise data, carry out the above mentioned test on a five hundred meters run; in such a case, the value of the litres of water sprayed shall be five times higher than the value shown on the table.

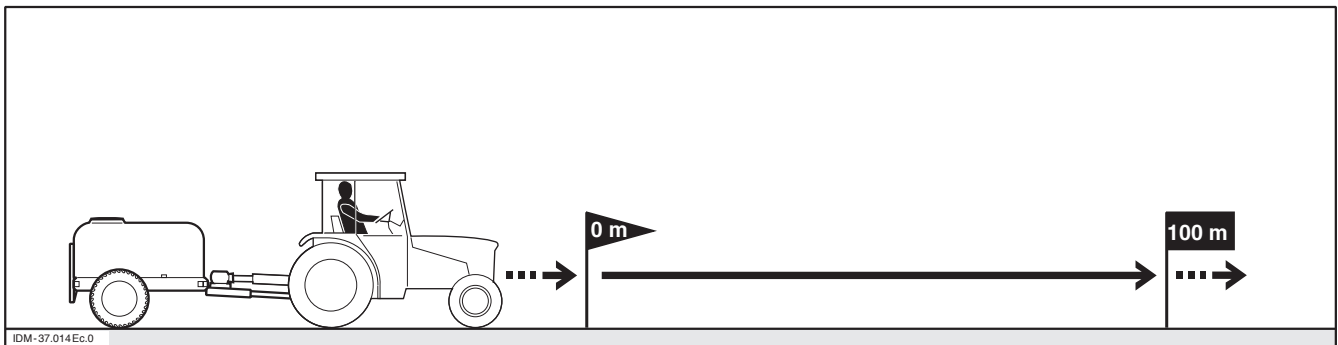

□ Formula for the checking of the fluid litres sprayed per hectare (l/ha)

$$\text{Quantity sprayed (l/ha)} = \frac{\text{Fluid per nozzle (l/min)} \times \text{constant } 600}{\text{Distance among jets (0.5 m)} \times \text{speed km/h}}$$

Said formula can be changed to obtain the necessary forward speed or to determine the quantity of fluid to be sprayed by each nozzle.

$$\text{Speed km/h} = \frac{\text{Fluid per nozzle (l/min)} \times \text{constant } 600}{\text{Quantity sprayed (l/ha)} \times \text{distance among jets}}$$

$$\text{Fluid per nozzle l/min} = \frac{\text{Sprayed quantity (l/ha)} \times \text{distance among jets} \times \text{speed km/h}}{\text{Constant } 600}$$

USE AND OPERATION 6

 **DANGER-WARNING:** the equipment has to be coupled to the tractor by only one operator, in absolute safety conditions.

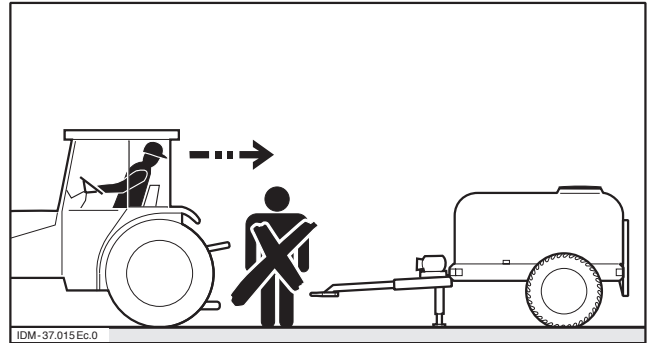

6.1. HITCHING TO TRACTOR

Before hitching the equipment to the tractor, make always sure that the tractor has a suitable power as well as proper size, in order to avoid towing and working problems.

Hitching depends on the equipment you have:

– Front tracker trailed units - hitching to tractor (see

paragraph 6.1.1)

– Mounted units - hitching to tractor (see paragraph 6.1.2)

– Trailed units - hitching to tractor (see paragraph 6.1.3)

– Removable units - hitching to tractor (see paragraph

6.1.1 Front tracker trailed units - hitching to tractor

- *Tractor hitch has to be positioned just next to the hitch A.*

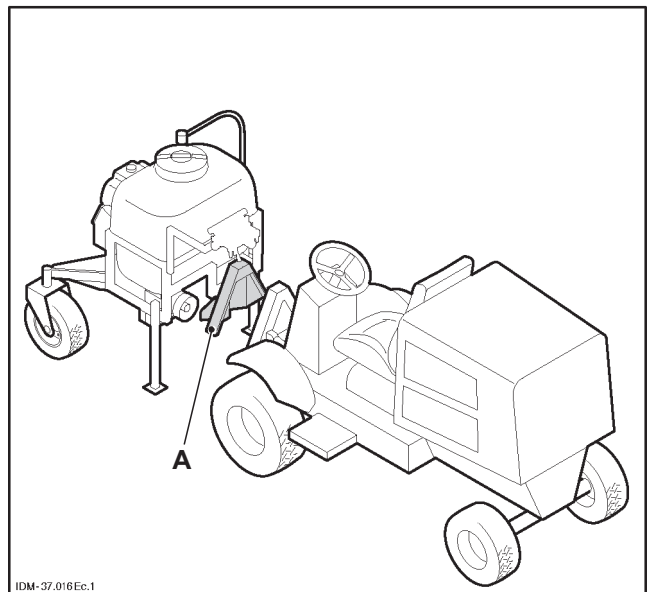

- Hitch the equipment.
- Lift support legs **B**.

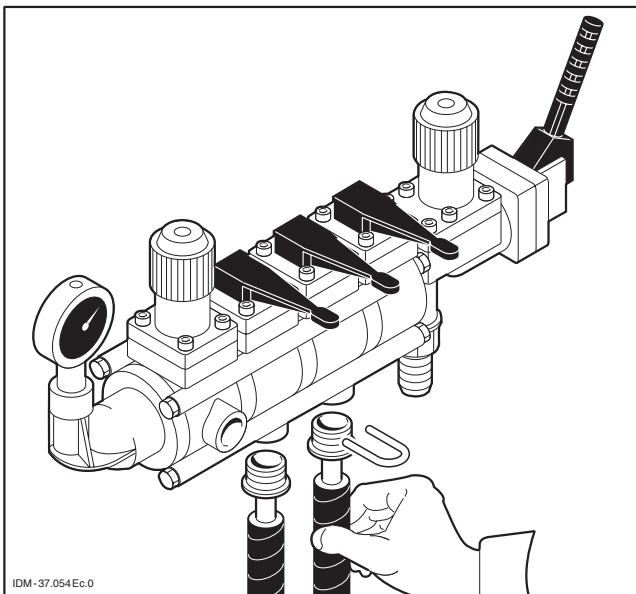
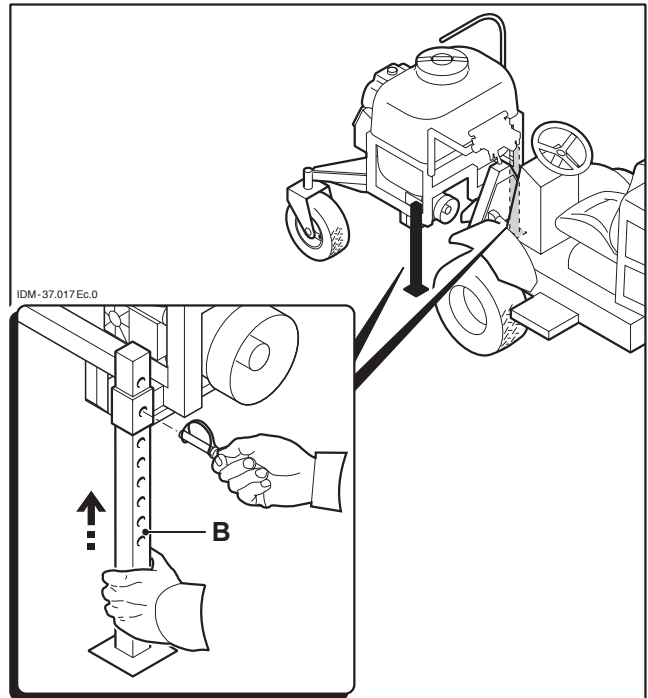

- Couple the boom feed pipes to the water distributor.

- Couple the cardan shaft to the tractor.

i **INFORMATION:** some information about checking whether the cardan shaft length is fair, is included in chapter 6.1.5

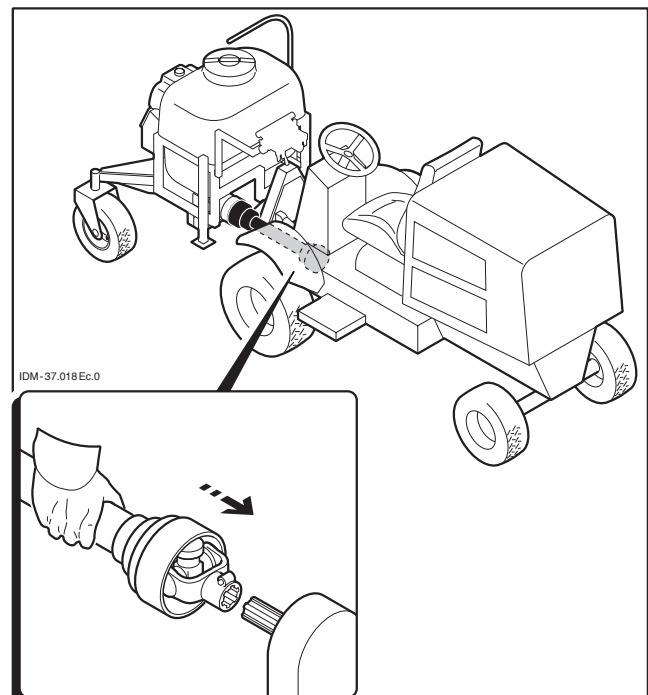

6.1.2 Mounted units - hitching to tractor

- Position the lower arms of the tractor height adjustment in line with pins **A**.
- Move the tractor backward until arm holes **F** are aligned with pins **A**.
- Turn off the engine, engage the parking brake and get out of the tractor removing and taking the ignition key.
- Hook the two arms to the pins.
- Adjust the third point **B** length and fasten it to the equipment through the relevant pin in the correct position, so that during the working phase, the equipment is perpendicular to the ground.

 **CAUTION:** always fit the locking pins **E**, in order to prevent arms from coming out from pins. Do not use unsuitable pins.

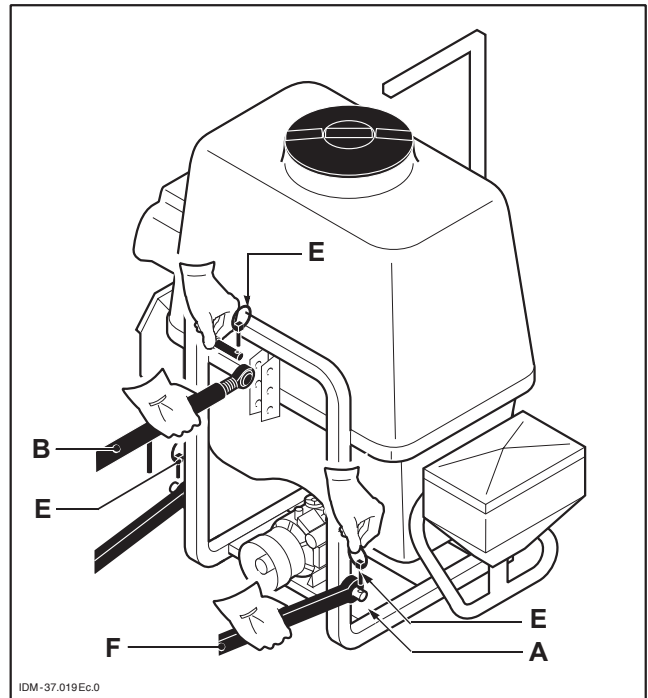

- Couple the cardan shaft to the tractor.

 **INFORMATION:** chapter 6.1.5 includes the instructions to check whether the cardan shaft length is right.

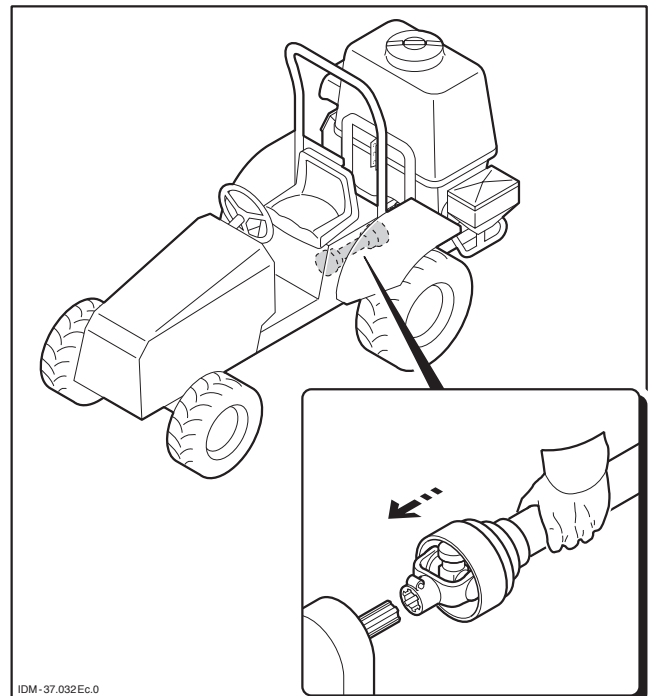

6.1.3 Trailed units - hitching to tractor

- Adjust support leg **A**, until trailed tank frame is parallel to the ground.

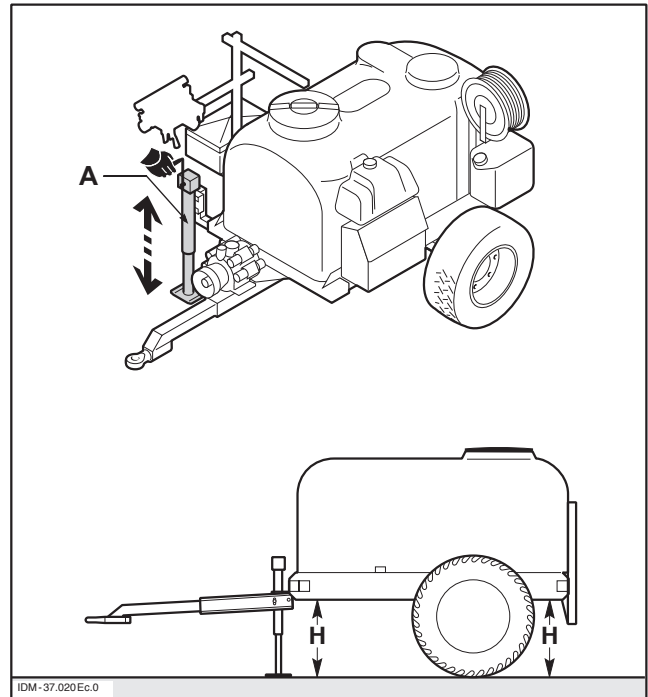

- If necessary, adjust drawbar height (see paragraph 5.1.) or modify (if possible) towing hitch height, in order to put both hitches at the same height.
- Move the tractor backward until the towing hitch eye and towing hitch **C** are aligned.
- Turn off the engine, engage the parking brake, get out of the tractor removing the ignition key and taking it away.
- Hitch the equipment to the tractor by inserting the pin **D** and the related lock pin **E**.

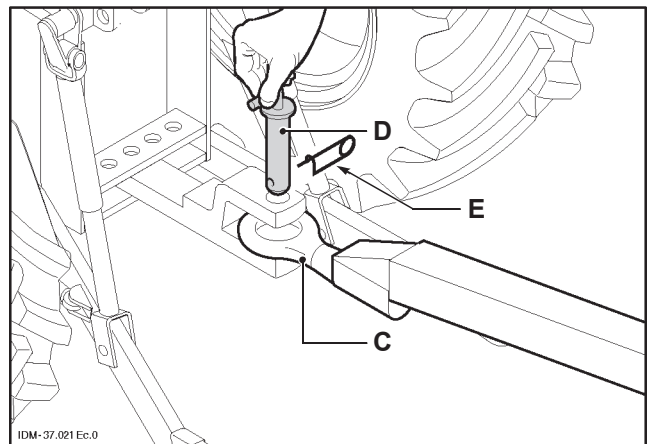

- Fold support A to its stowage position.

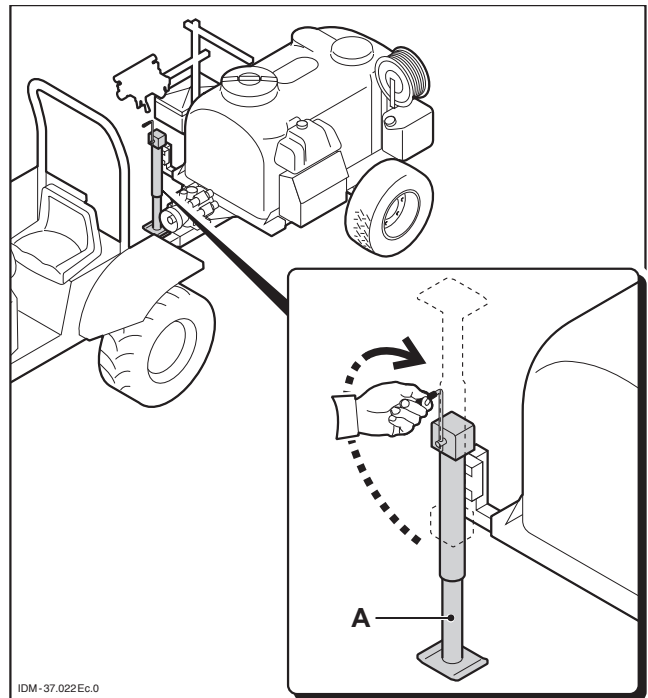

- Couple the cardan shaft to the tractor.

i **INFORMATION:** chapter 6.1.5 includes the instructions to check whether the cardan shaft length is right.

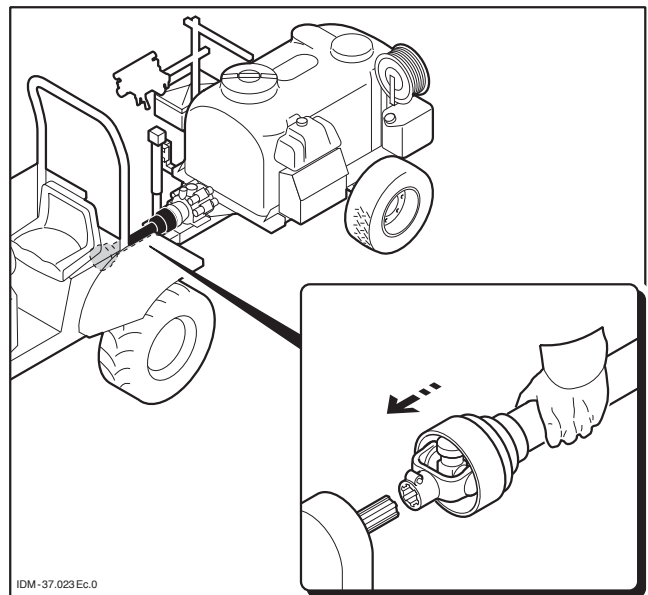

6.1.4 Removable units - hitching to tractor

- Move the tractor below the equipment, so that hitch points are at the same height.

 **CAUTION:** stop the vehicle, engage the parking brake and take the ignition key with you.

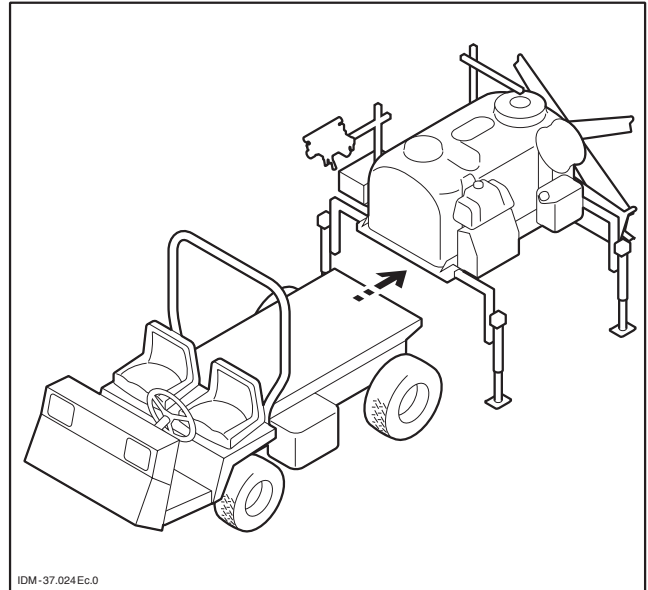

- Rest the equipment on the tractor, lowering the support legs.

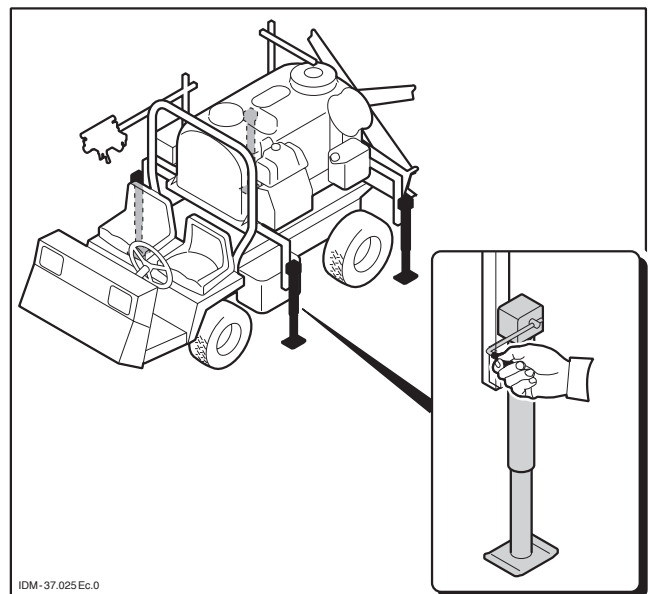

- Fasten the equipment to the tractor with the screws and the clamp supplied (see paragraph 4.3.).

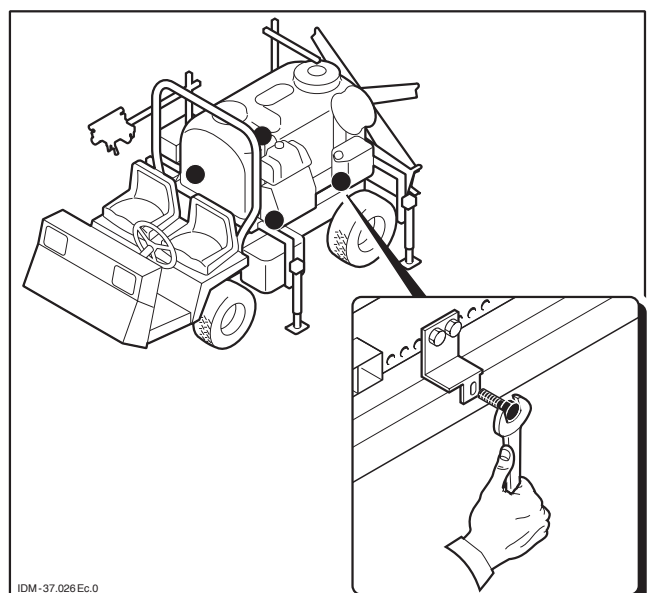

- Reclose the support legs.
- Couple the cardan shaft to the tractor.

i **INFORMATION:** chapter 6.1.5 includes the instructions to check whether the cardan shaft length is right.

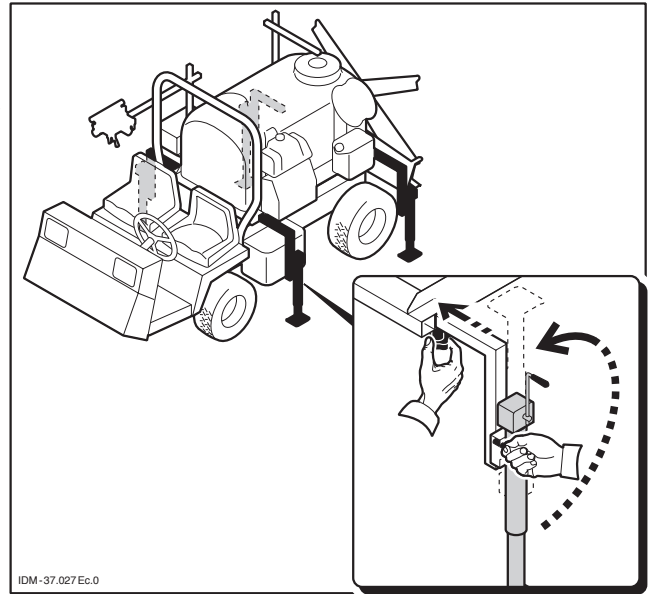
IDM-37.027 Ec.0

6.1.5 Cardan shaft coupling (just for TRAILED UNITS, FRONT TRACKER TRAILED UNITS and MOUNTED UNITS)

! DANGER-WARNING: This operation must be carried out with the tractor turned off and previously disengaging the PTO.

The cardan shaft must have a suitable length in order to avoid any jamming in conditions of minimum extension or an excessive risk of removal in conditions of maximum extension.

To set the correct cardan shaft length, follow the procedure below.

- Position the sprayer at a minimum distance between the tractor PTO and the pump spline shaft as shown in the figure

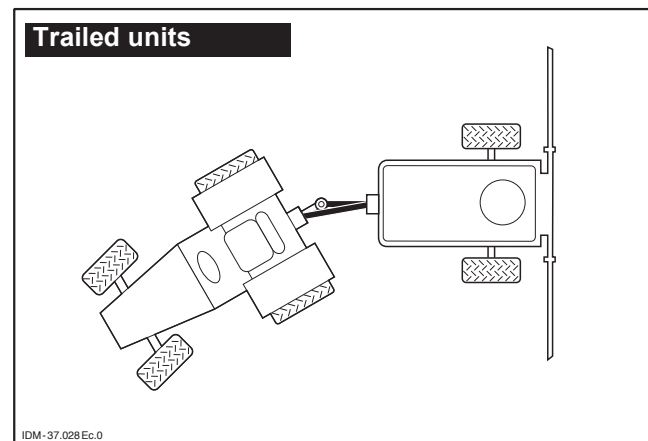
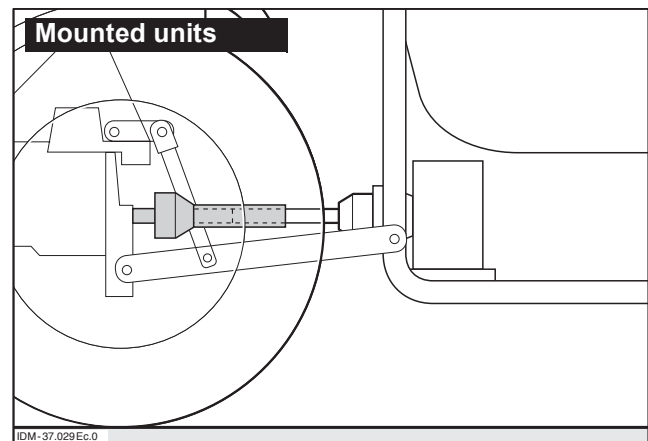
IDM-37.029 Ec.0

IDM-37.029 Ec.0

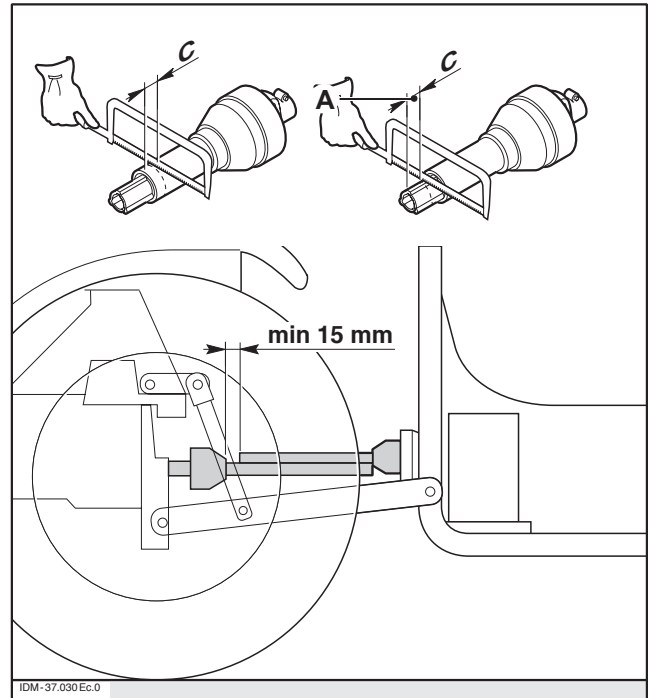
- Remove the inner tube from the guard of the cardan shaft and fix one half to the pump and the other half to the tractor.
- Bring the two halves close together and make sure that once the cardan shaft has been completely closed, the stroke is at least of 15 mm.
- Cut either the exceeding parts of the tube or of guard C, whenever necessary.



i **INFORMATION:** During the operation, the telescopic tubes must be overlapped by at least 1/3 of their length.

- Before the two parts are joined together again, remove the metallic burs, clean and lubricate the inner tube.
- To avoid damage, make sure the space required by the cardan shaft during the tractor operation is free.
- During the operation, standard cardan shafts must not exceed a misalignment of 35° max.
- In case of misalignment exceeding 35°, use wide angle cardan shafts.

For any additional information relevant to the cardan shaft, such as operation and maintenance, see the specific manual enclosed herein.

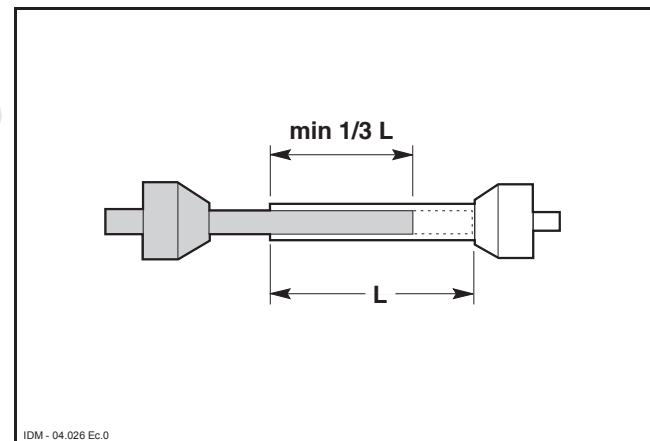

6.1.6 Hydraulic connection (if fitted)

Said operation is to be carried out exclusively on equipment supplied with hydraulic controls.

- **pressure pipe (P)**, fitted on the quick hitch and recognisable by the red protection cap;
- **return pipe (T)** fitted on the quick hitch and recognisable by the blue protection cap and by the check valve fitted on the electrohydraulic systems only.

Connect the hydraulic "pressure" pipe to the tractor pressure intake and the "return" pipe to the tractor return intake.

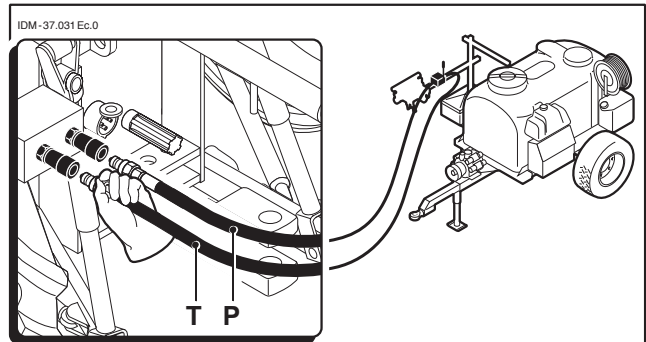

CAUTION: Whenever the identification of the hydraulic intakes (pressure-return) on the tractor is not made possible, previously check their function through the positioning of the relevant changeover lever fitted on the tractor.

6.2. PRECAUTIONS TO BE ADOPTED DURING THE TRANSFER WITH HITCHED EQUIPMENT

Before moving with the equipment hitched to the tractor, it is always necessary to carry out the following operations:

- *make sure the equipment has been properly hitched, see paragraph § 6.1.;*
- *make sure the tractor PTO has been disengaged;*
- *make sure the spraying boom has been folded and the relevant locking devices to prevent its unfolding have been correctly fitted (see annex F);*
- *make sure that no chemical substance is inside the spray product tank. In this case, see chapter 6.9.*

6.3. UNCOUPLING FROM THE TRACTOR

Uncoupling procedures depend on the equipment you have:

- Front tracker trailed units - uncoupling from tractor (see paragraph 6.3.1)
- Mounted units - uncoupling from tractor (see paragraph 6.3.2)
- Trailed units - uncoupling from tractor (see paragraph 6.3.3)
- Removable units - uncoupling from tractor (see paragraph 6.3.4)

6.3.1 Front tracker trailed units - uncoupling from tractor

- Turn the tractor off, engage the parking brake and take the ignition key with you.
- Lower support legs **B**.

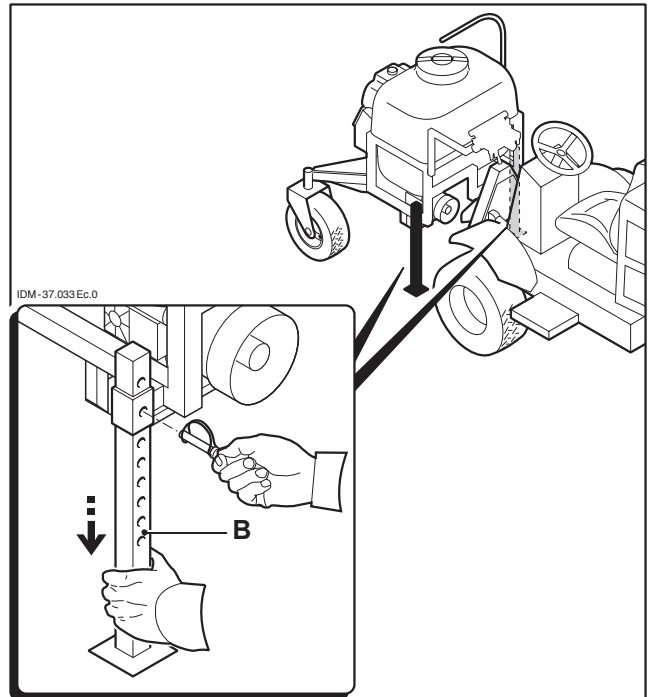

- Uncouple the cardan shaft **C**.
- Uncouple the boom feed pipes from the water distributor.
- Uncouple the tractor from the equipment and reverse it.

! **DANGER-WARNING:** There could be some product spills, therefore it is necessary to use protective gloves.

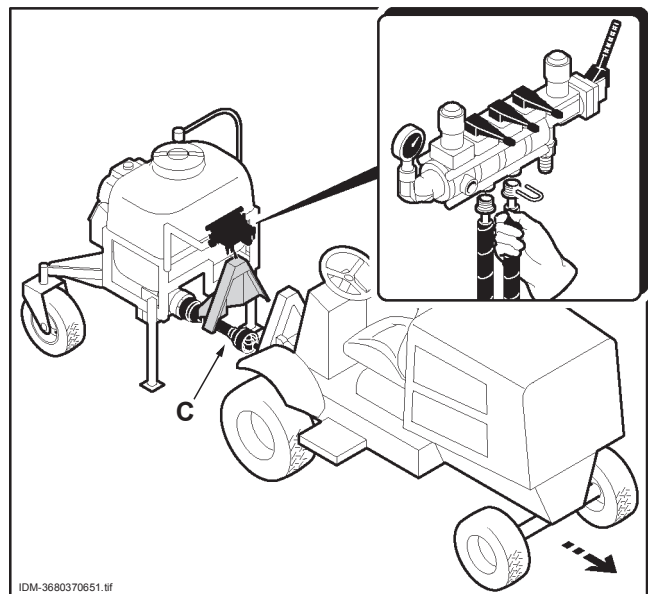

6.3.2 Mounted units - uncoupling from the tractor

- Stand the equipment on the ground.
- Stop the tractor, engage the parking brake and take the ignition key with you.
- Uncouple the three-point linkage.
- Uncouple the cardan shaft and place it on support **B**.

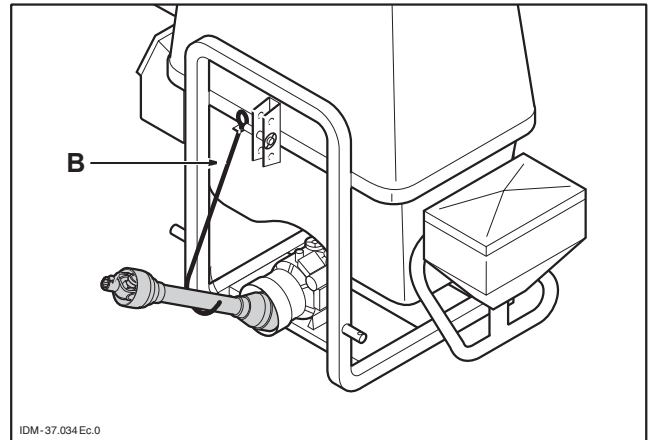

6.3.3 Trailed units - uncoupling from tractor

- Stop the tractor, engage the parking brake and take the ignition key with you.
- Rotate support leg **A** and lower it by means of the handle.

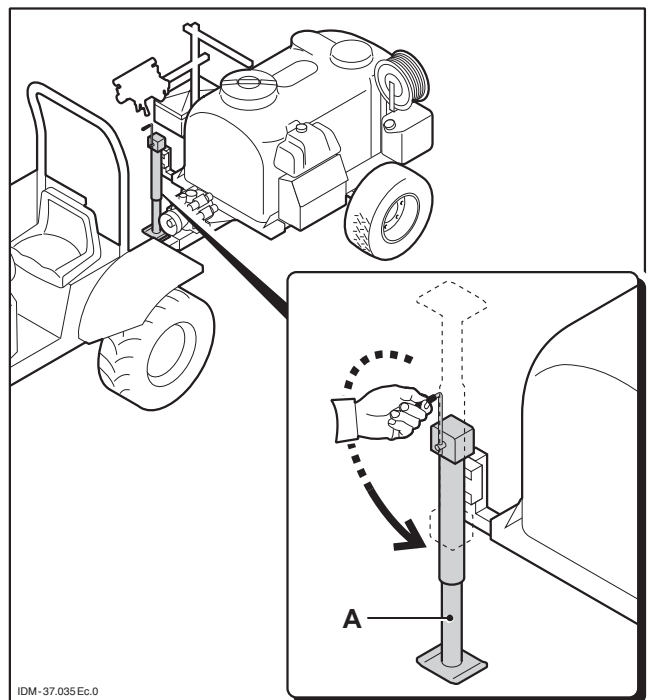

- Uncouple the cardan shaft and place it on support **B**.

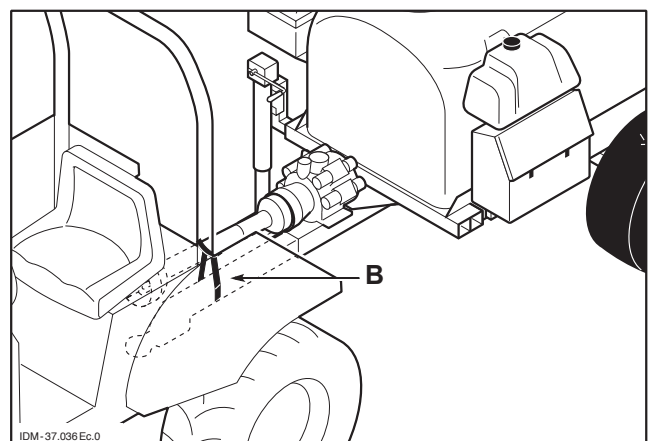

- Unplug both pin **E** and coupling pin **D**.

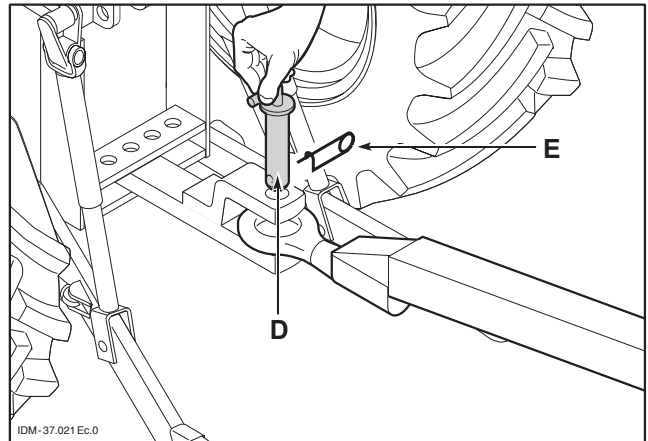

6.3.4 Removable units - uncoupling from the tractor

- Stop the tractor, engage the parking brake and take the ignition key with you.
- Loosen the securing screws from the tractor frame.
- Place support legs **A** in the right position.

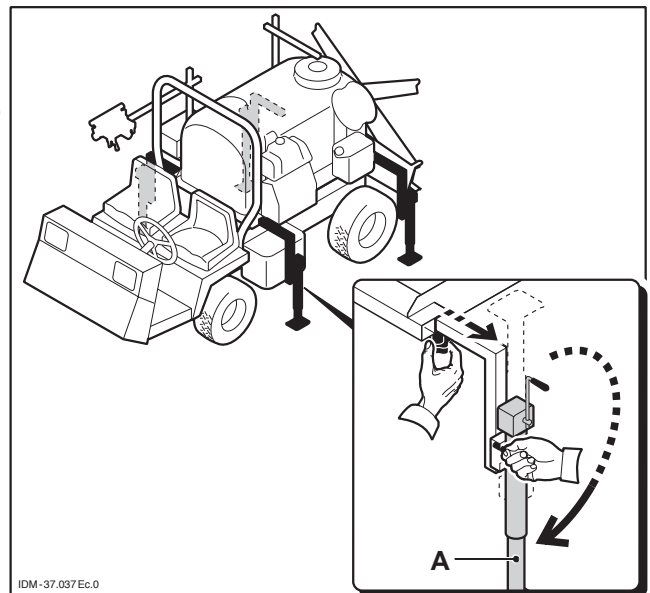

- Uncouple the clamps from the tractor frame.
- Lift the equipment by means of handles **B**.
- Uncouple both the cardan shaft and the water system pipes (if fitted).

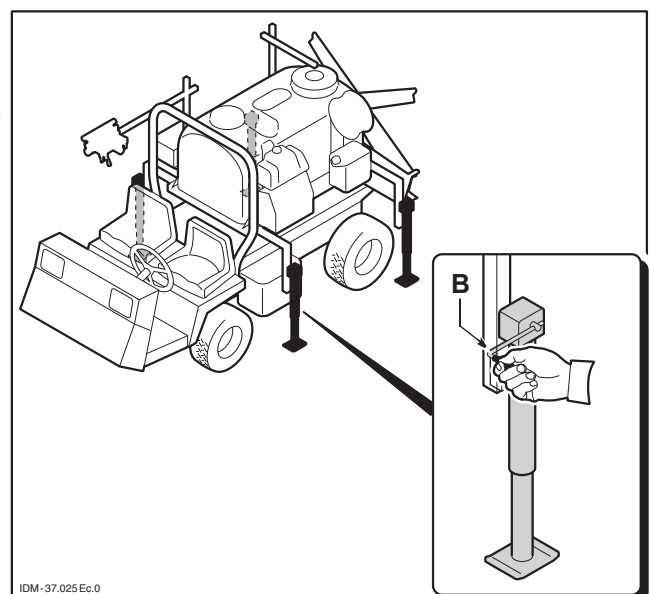

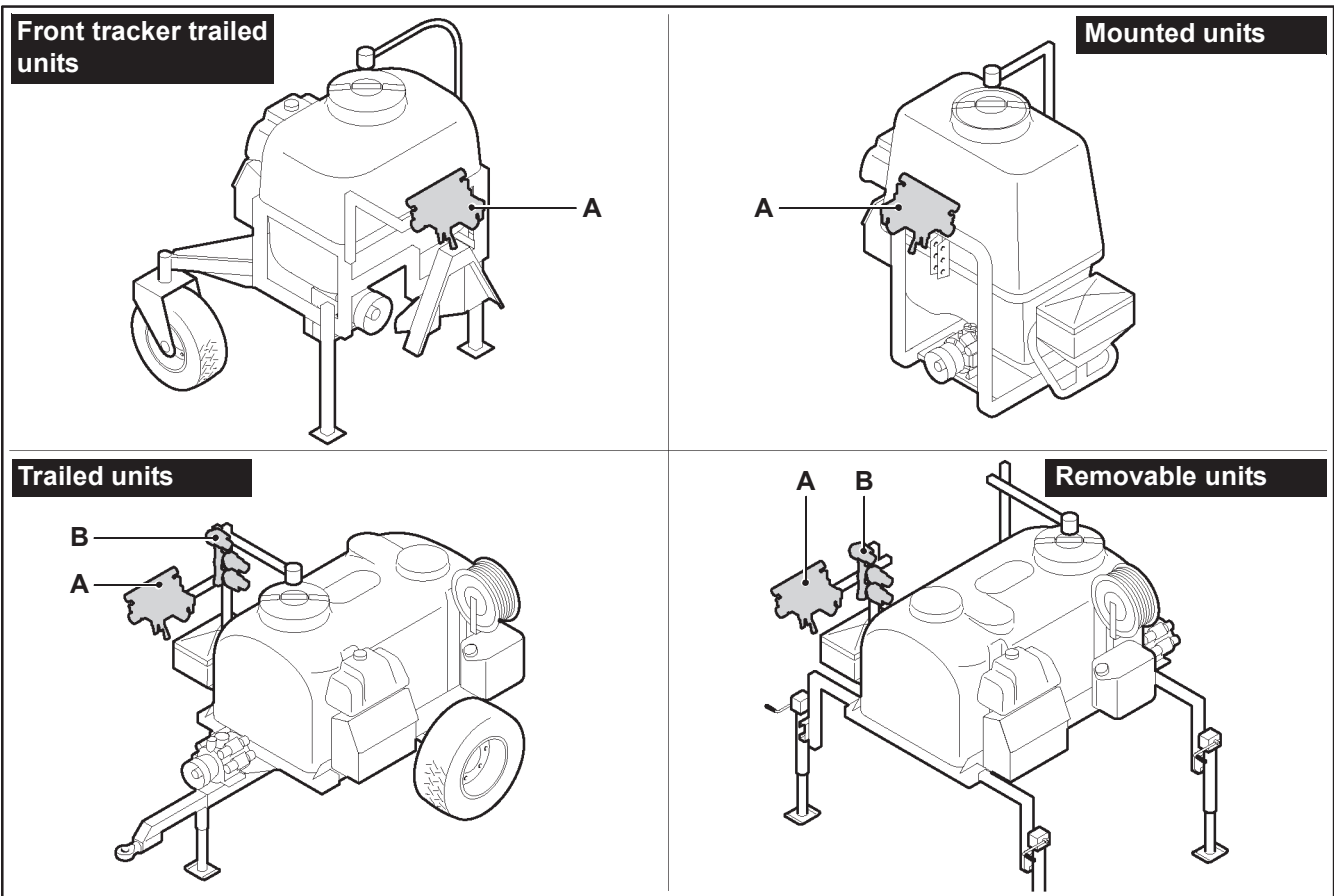
6.4. DESCRIPTION OF CONTROLS

The diagram shows the position and function of the controls on the equipment. More detailed information on use and settings are given in the following sections.

A - Control unit

Whether one or more boom sections are folded, both chemical product and liquid fertilizer spraying are kept even by the distributor, assembled on weed-killing units. It also has the purpose of adjusting the working pressure.

Users can be supplied, according to their needs, with three different distributor models:

STANDARD 461 (paragraph 6.4.1)

IDROMINUS (paragraph 6.4.2)

ELECTRO 461 (paragraph 6.4.3)

B - Stop valve (if fitted)

By properly rotating the control valve levers it is possible to wash the system.

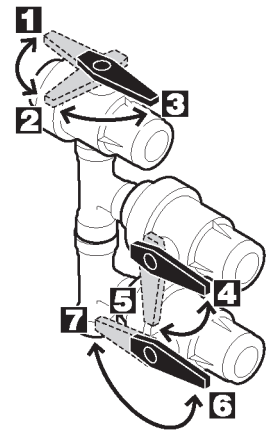
B
FASE DI LAVORO
SPRAYING
3
5
6
PHASE DE TRAVAIL
SPRITZARBEIT
FASE DE TRABAJO
SPUITEN
РАБОЧИЙ ЗТАП
LAVAGGIO IMPIANTO
CLEANING
2
4
7
LAVAGE SYSTÈME
REINIGEN
LAVAJE INSTALACIÒN
REINIGEN
СИСТЕМА ОЧИСТКИ

IDM-3680370631.tif

6.4.1 Description of the distributor (STANDARD 461)

The control unit, fitted on weed killing units, adjusts the working pressure.

A - Manometer

Shows the control unit working pressure.

B - Main on/off control lever

Upwards: control unit off

Downwards: control unit on.

C - Control unit pressure adjusting knob

Turn clockwise to increase pressure.

Turn counterclockwise to reduce pressure.

D - Max. pressure adjusting knob.

Turn clockwise to increase the max. working pressure.

Turn counterclockwise to reduce the max. working pressure.

E - Boom section feeding control levers.

Upwards: feeding on.

Downwards: feeding off.

F - Additional attachment control lever (ex. nozzle).

Lever up; feed open.

Lever down; feed closed.

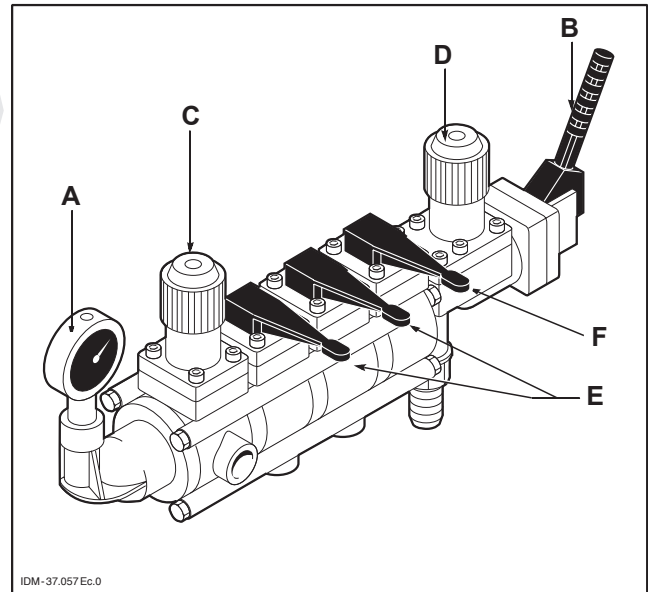

□ Control unit adjustment

Before adjusting pressure with working equipment, set up the water distributor as follows.

- Place levers **B**, **E** and **F** as shown in the figure.
- Turn knob **C** clockwise, up to tighten it completely (pressure adjustment off)
- Turn knob **D** counterclockwise up to see the thread on the fixed part of the adjuster.

At this point, maximum working pressure can be adjusted as follows.

 **CAUTION:** Use fresh water to perform this operation.

- Start the tractor engine and set the power take off rpm to 540.
- Turn lever **B** down (pressure).
- To reach the max. required pressure (e.g. 12÷15 bar), turn knob **D** clockwise and check the manometer.

- According to the type of nozzle, see the spraying table to draw necessary data (§ 5.1., annex A or H, l/ha sprayed quantity, km/h forward speed, bar pressure).
- Adjust the PTO rpm, according to the tractor forward speed (see § 5.4.).
- To reach the correct working pressure (e.g. 2 bar), turn knob **C** counterclockwise and check the manometer.
- Turn levers **E** and **F** up.
- Should working pressure change, reset it through knob **C**.

As soon as the above mentioned adjustments have been performed, the control unit is ready to be used.

6.4.2 Description of the distributor (IDROMINUS)

The control unit, fitted on weed killing units, adjusts the working pressure and keeps the spraying of chemical products and liquid fertilisers steady, even if one or more sections are folded.

A - Manometer

Shows the control unit working pressure.

B - Pressure control knobs for each sector.

- Turn clockwise to increase pressure.
- Turn counterclockwise to reduce pressure.

C - Boom section feeding control levers.

- Upwards: feeding on.
- Downwards: feeding off.

D - Extra supply control levers (ex. SPRAY GUN) and tank inside washing.

- Lever up; function on.
- Lever down; function off.

E - General closing and opening control lever.

- Lever up; distributor open (pressure).
- Lever down; distributor closed (discharge).

F - Control unit pressure adjusting knob

- Turn clockwise to increase pressure.
- Turn counterclockwise to reduce pressure.

G - Delivery filter.

It filters the jet fluid and prevents nozzle bodies from clogging.

H - Proportional closing cock

Pos.1 - Cock closed - maximum pressure on additional section (NOZZLE)

Pos.2 - Cock open - pressure distributed over all sections.

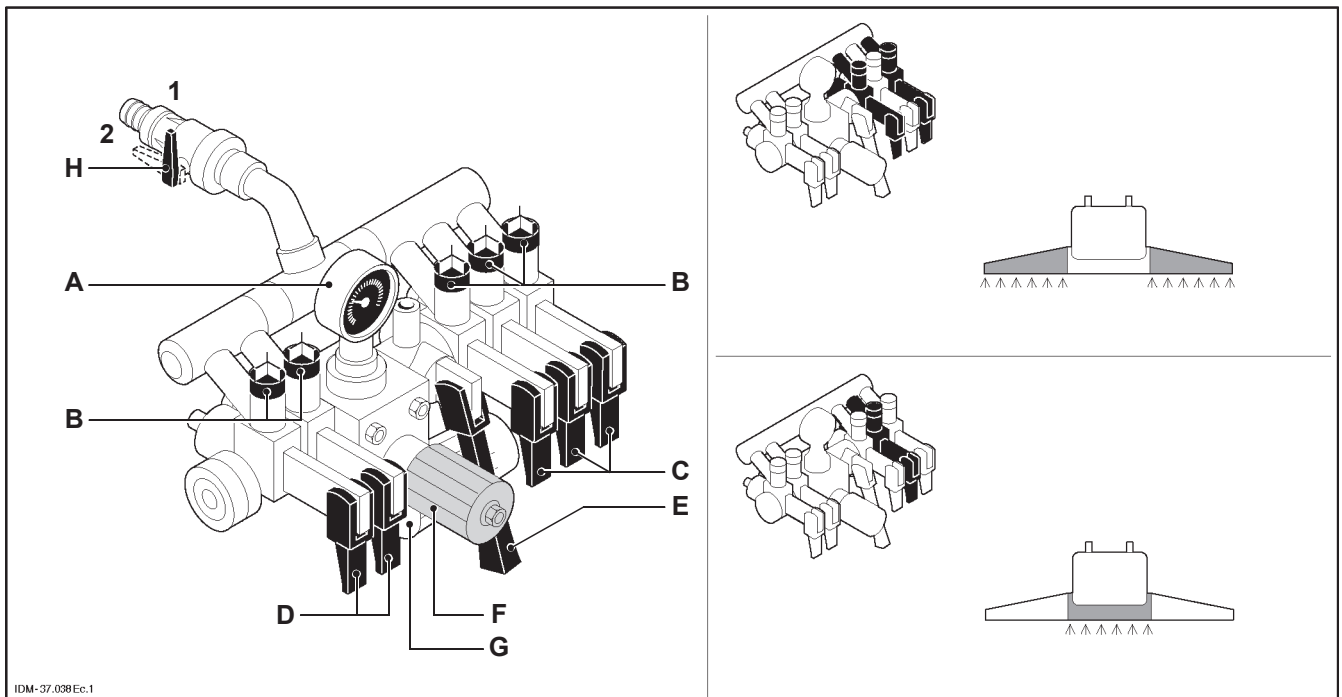

IDM-37.038 Ec.1

□ Proportional closing cock

Before adjusting pressure, while the equipment is working, it is necessary to prepare the water distributor, as follows.

- Make sure that the valve **H** is turned on (pos. 2).
- Rotate knob **F** anticlockwise, until you can see the beginning of the thread on the adjusting body fixed part.
- Move lever **E** down.
- Move levers **C** down (feed closed).
- Rotate knobs **B** first clockwise up to the stop, then anticlockwise of 2 revolutions and 1/2.

□ You can then adjust pressure as follows.

 **CAUTION:** use clean water to adjust the working pressure.

- Start the tractor engine and set the number of the power take off rpm to 540.
- Move lever **E** up.
- Move lever **C** up (feed open).
- Rotate knob **F** and check manometer **A** up to reach a 5-bar pressure.
- Move first lever **C** down (feed closed).
The pressure displayed on manometer **A** can change (it can rise or drop) and, consequently, adjust knob **B** to reset the pressure to the selected value (5 bars).
- Move again first lever **C** up and repeat the above-mentioned procedure for the other lever **C**.

Once all adjustments have been carried out, the distributor is ready to use. Any boom section folding will not affect liquid quantity sprayed per hectare.

- Get data you need from distribution table (paragraph 5.4.) according to the nozzle used (quantity distributed in l/ha, forward speed in km/h and pressure in bars).
- Adjust the number of power take off rpm, according to the forward speed (see paragraph 5.4.).

 **INFORMATION:** after replacing nozzles, working pressure needs to be adjusted again. If this distributor is used with pumps with different flow rates, change the baffle.

In order to carry out this operation, it is advisable to apply to your dealer.

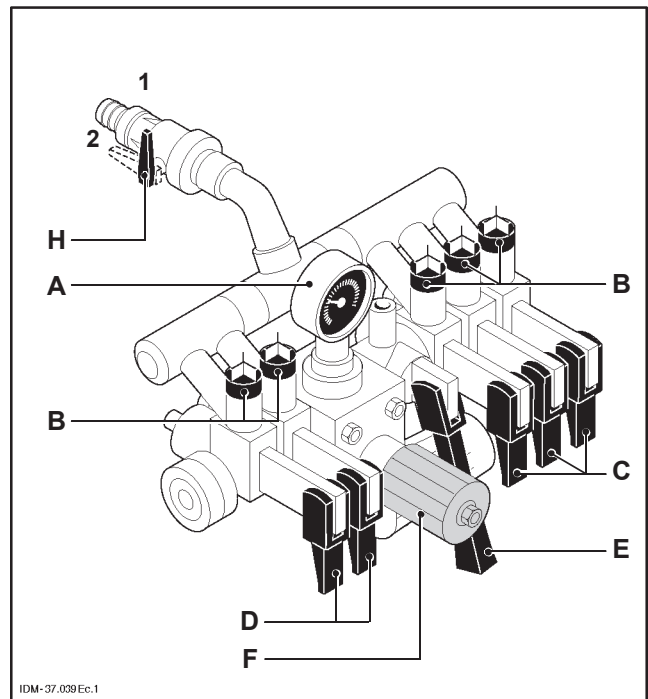

6.4.3 Description of the distributor (ELECTRO 461)

The control unit, fitted on weed killing units, adjusts the working pressure and keeps the spraying of chemical products and liquid fertilisers steady, even if one or more sections are folded.

The opening and closing of the control unit and of the single sections, as well as the working pressure adjustment occur through electric controls.

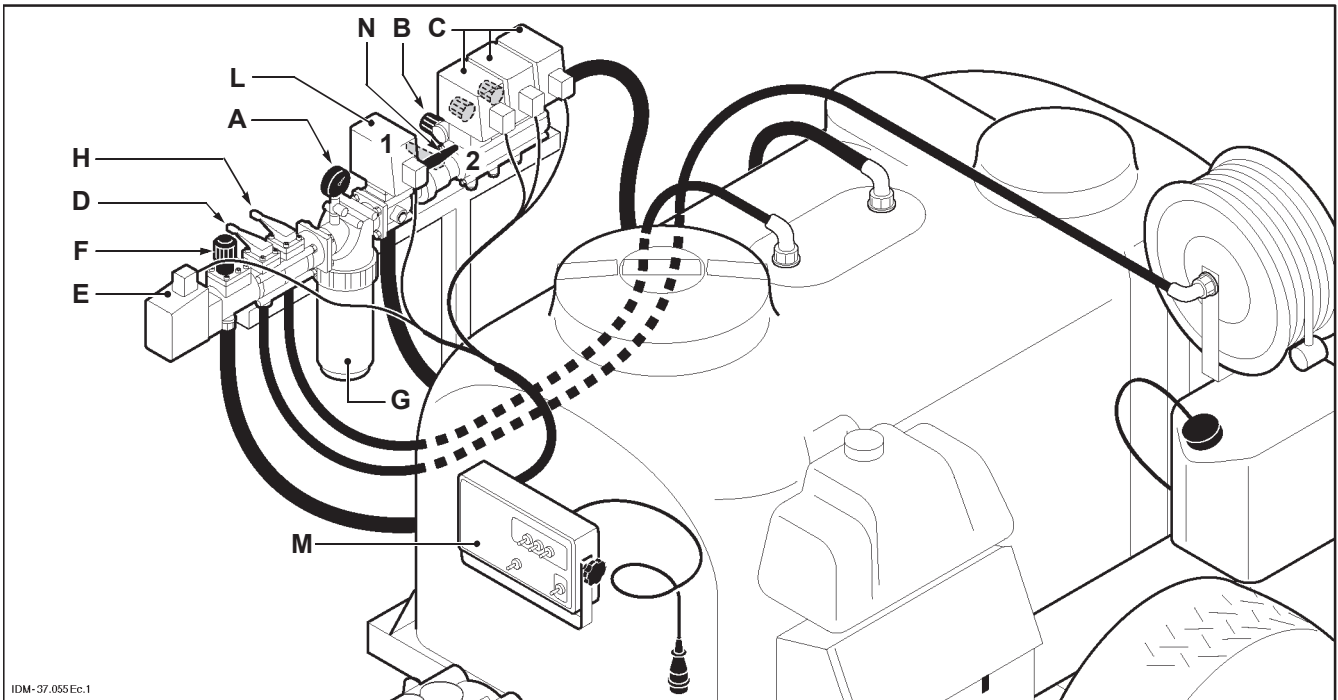

A - Manometer

Shows the control unit working pressure.

B - Pressure adjustment knobs of the single sections.

Turn clockwise to increase pressure.

Turn counterclockwise to reduce pressure.

C - Single section unfolding and folding motors.

D - Mixer feeding control lever (and mixer fitted in the cover, if supplied).

Upwards position: mixer enabled.

Downwards position: mixer disabled.

E - Main control unit on/off motor.

F - Max. pressure adjusting knob.

Turn clockwise to increase the max. working pressure.

Turn counterclockwise to reduce the max. working pressure.

G - Delivery filter.

It filters the jet fluid, thus avoiding nozzle bodies clogging.

H - Additional attachment control lever.

Upwards: feeding on.

Downwards: feeding off.

L - Working pressure adjustment motor.

M - Control board.

Enables the main control unit functions.

N - Boom sections closing valve (on demand).

Position 1- valve off; maximum pressure on valves **D** and **M**.

Position 2- valve on; maximum pressure distributed to all sections.

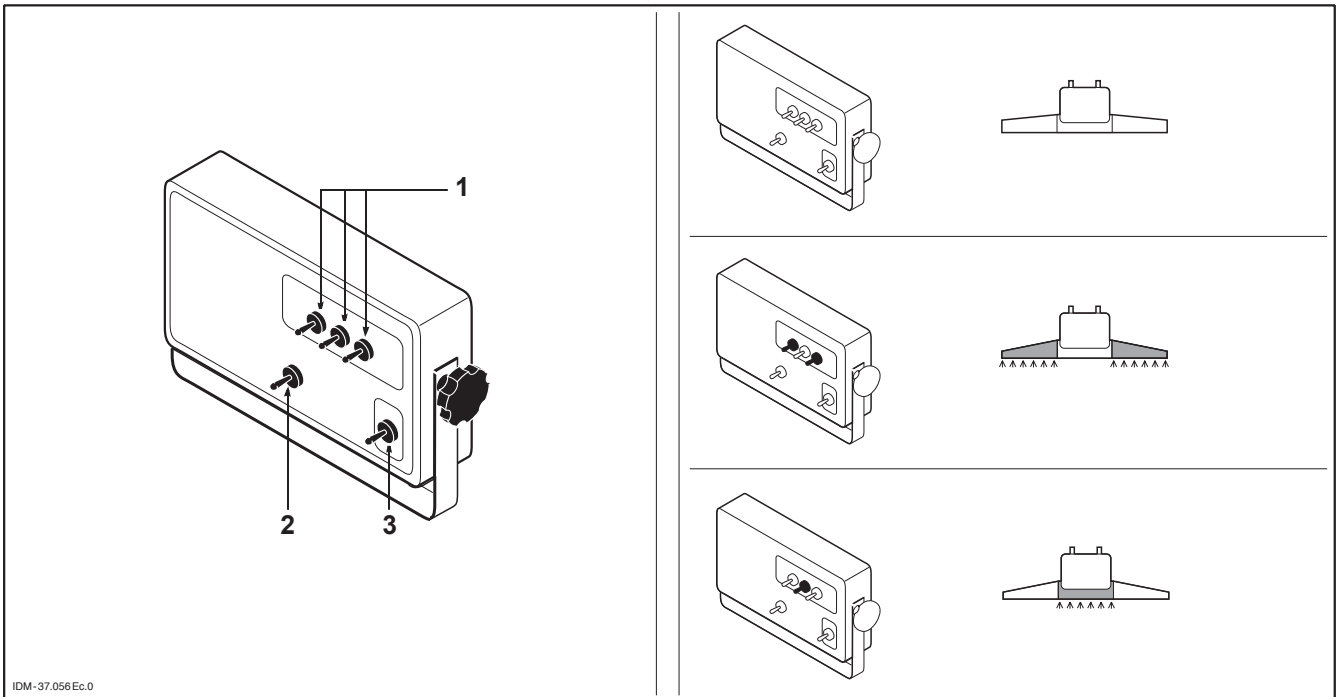

1 - Boom section feeding control switches.

Press switches upwards to feed the boom.

Press switches downwards to disable the boom feeding.

2 - Working pressure adjusting switch.

Press the switch upwards to increase the working pressure.

Press the switch downwards to decrease the working pressure.

3 - On/off control unit switch

Press the switch upwards to feed the control unit.

Press the switch downwards to disable the control unit.

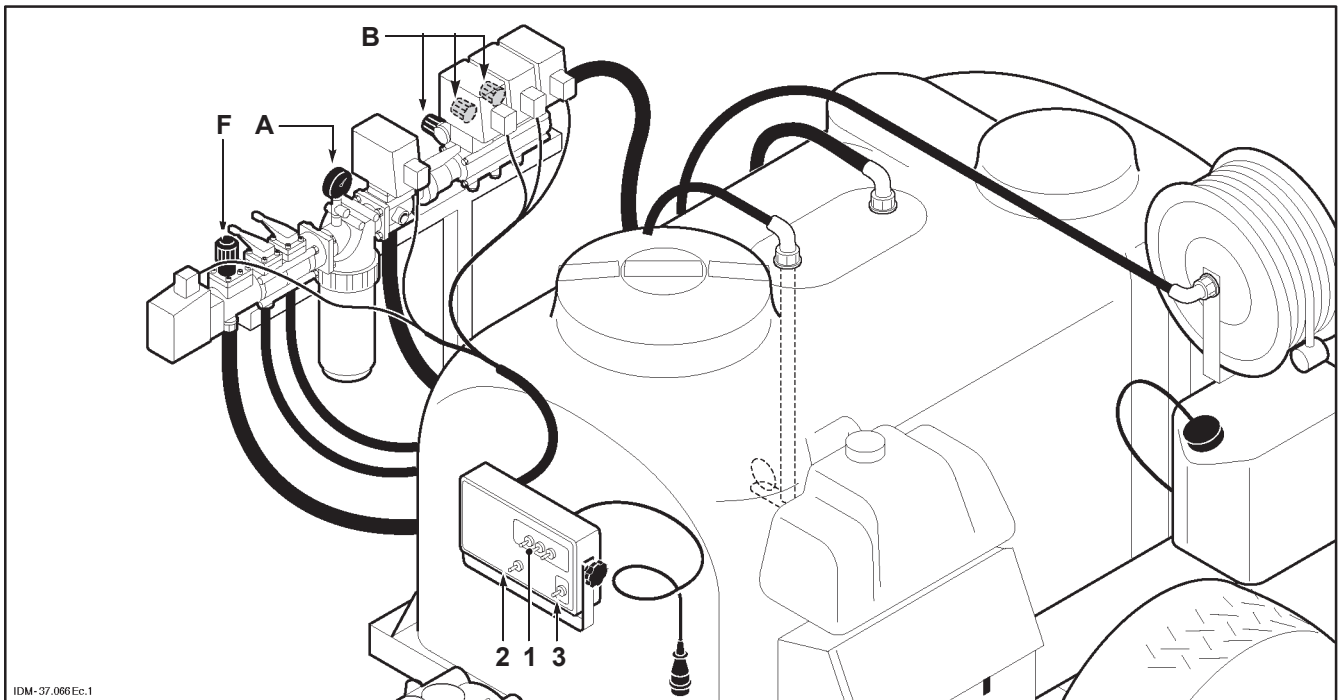

□ Control unit adjustment

Before adjusting pressure with working equipment, set up the water distributor as follows.

- Press switches **1** and **3** downwards (control unit feeding off and boom sections folded).
- Turn knob **F** counterclockwise, up to see the thread on the fixed part of the adjuster.
- Rotate knobs **B** clockwise up to the stop.

Once the distributor has been prepared, adjust its maximum pressure as follows.

 **CAUTION:** Use fresh water to adjust the working pressure.

- Set the number of the power take off rpm to 540.
- Press switch **3** upwards (feeding on).
- Press switch **2** upward, until the maximum pressure is reached.
- To reach the required pressure (e.g. 12÷15 bar), turn knob **F** clockwise and check the manometer.
- To reach the required working pressure (e.g. 5 bar), press switch **2** downwards.
- Press switches **1** upwards (boom section feeding on).
- Press switch **2** upward, until a 5-bar working pressure is reached.

- Press first switch **1** downwards (feeding off). Pressure shown on manometer **A** will change: according to its increase or decrease, adjust knob **B** until pressure reaches the pre-set value (5 bar)
- Bring first switch **1** upwards and repeat the same operation with the other switches **1**.

Once all adjustments have been carried out, the distributor is ready to use. Any boom section folding will not affect liquid quantity sprayed per hectare.

 **INFORMATION:** Adjust the working pressure whenever spraying nozzles are replaced.

- Get data you need from the distribution table (paragraph 5.4.) according to the nozzle used (quantity distributed in l/ha, forward speed in km/h and pressure in bars).

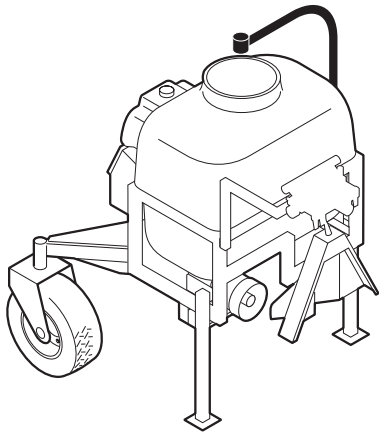
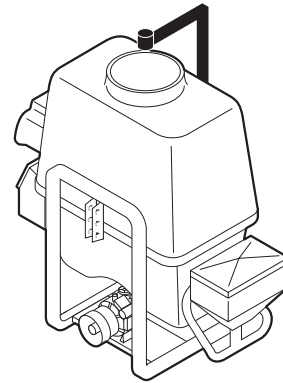
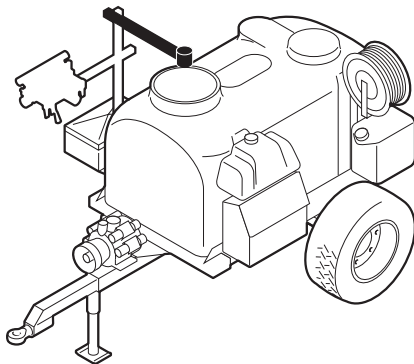
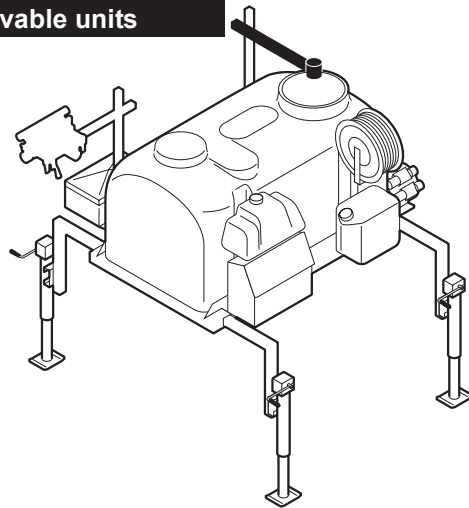
Front tracker trailed units

Mounted units

Trailed units

Removable units

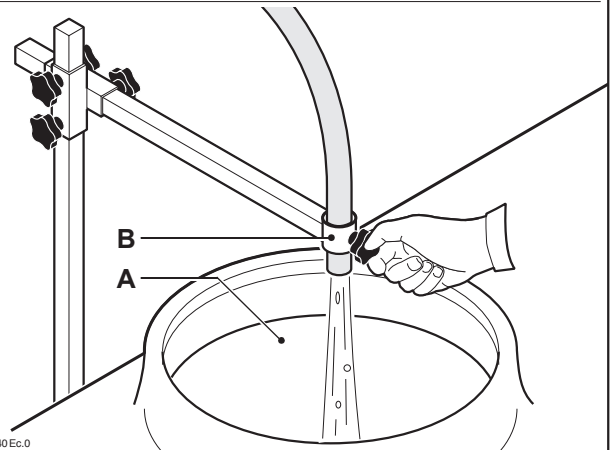
6.5. TANK FILLING

i **INFORMATION:** when filling spray product tank, make sure that the fresh water container is full of clean water and, if necessary, fill it up.

- Use an outside water source or a tank placed at a higher level than the filling hole **A**.
- Put the rubber on the support **B** and fill the tank.



IDM-37.040 Ec.0

6.6. CHEMICAL PRODUCTS HANDLING

! DANGER-WARNING: Make sure to adopt all safety precautions to avoid any active or passive contamination.

- Wear protective clothes well tightened and of the right size to avoid any movement hindrance .
- Use suitable and hard-wearing gloves to ensure a safe grip of controls and equipment.
- Cuts and grazes must be protected from the contact with chemical products; furthermore, wear a protective mask, helmet and goggles whenever necessary.

Should protective filters be used, either supplied with safety cabs or protective masks, previously make sure the filter is suitable for the product used, according to

the Manufacturers' instructions.

- Comply with the maintenance instructions relevant to the filters.
- Filters must not be scattered around, but they must be disposed of according to the Manufacturer's instructions and in compliance with the law in force in the user's country.
- Chemical products must be kept out of the reach of children, handicapped persons or inexperienced personnel.
- In case of accidental contact of the chemical product with skin, clean it immediately with clean water (or solvent, according to the instructions).
- In case of sickness, consult a doctor immediately,

6.7. CHEMICAL PRODUCT - MIXTURE PREPARATION

! DANGER-WARNING: It is absolutely forbidden to use non-expressly authorized products for spraying on golf fields and green areas. Read carefully instructions and information relevant to the chemical products to be sprayed printed by the Manufacturer on the packaging.

- Prepare a mix of water and chemical product according to the Manufacturer's instructions.

Unless otherwise prescribed, follow the instructions below.

- Make sure the equipment is clean.
- Fill the sprayer tank with water up to **1/2** or **2/3** of maximum level required.
- Set valve levers **C**, **D** and **E** as shown in the figure.

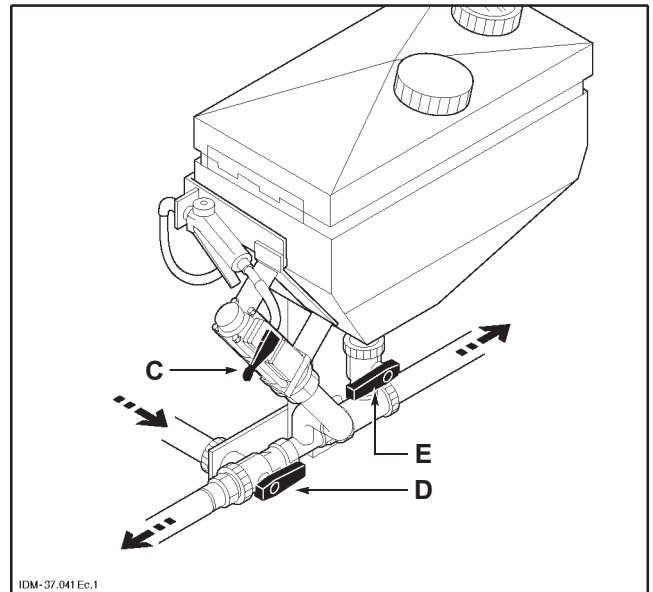

- Start the tractor engine and set the number of the power take off rpm to 540.
- Fill the tank with 10 cm of water approx, by opening valve **F**.

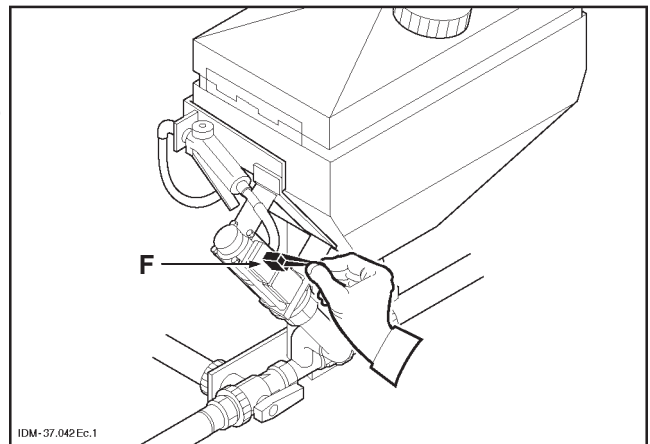

- Open cover **G**, keeping valve **D** open and pour the chemical product to mix.

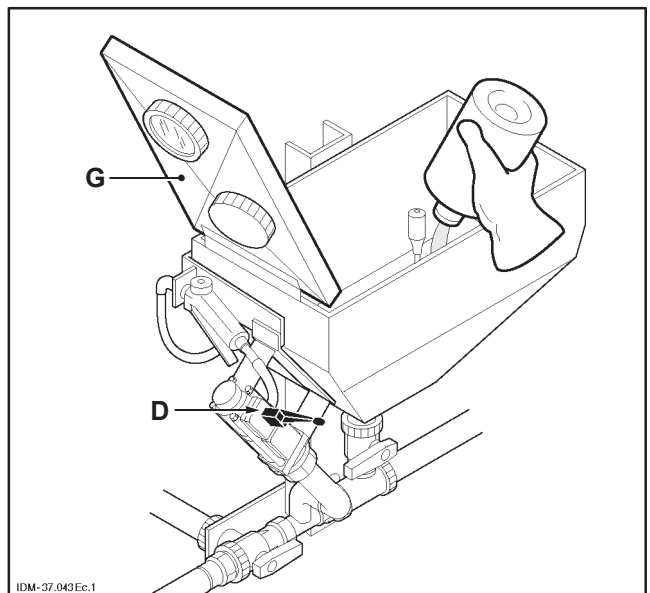

- Rinse the product container or bag through valve **H**
- Add antifoaming additive (if required).

⚠ DANGER-WARNING: do not open the valve (**H**) before placing the container upon the nozzle, in order to prevent water spilling, that could hurt the operator.

⚠ DANGER-WARNING: empty packaging must not be scattered around, but they must be disposed of in compliance with the laws in force in the user's country.

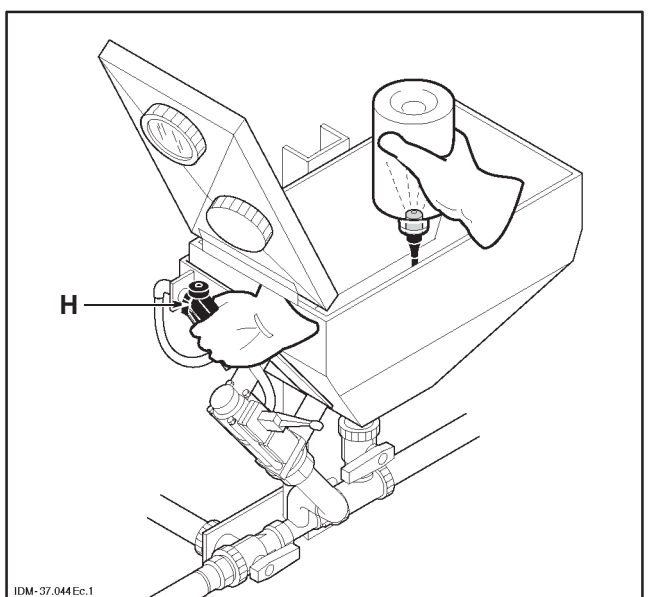

Front tracker trailed units

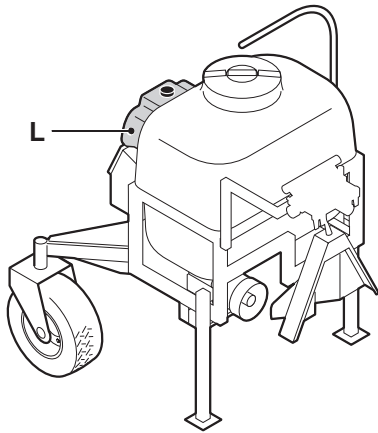

Mounted units

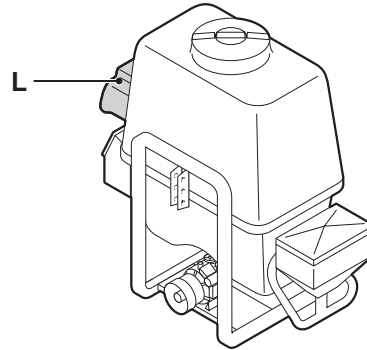

Trailed units

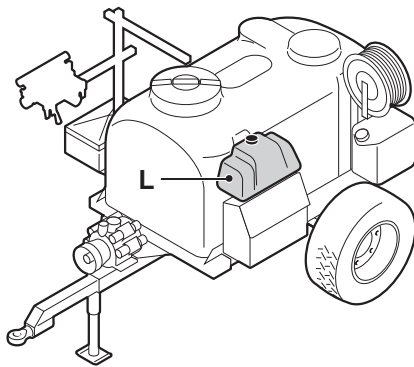

Removable units

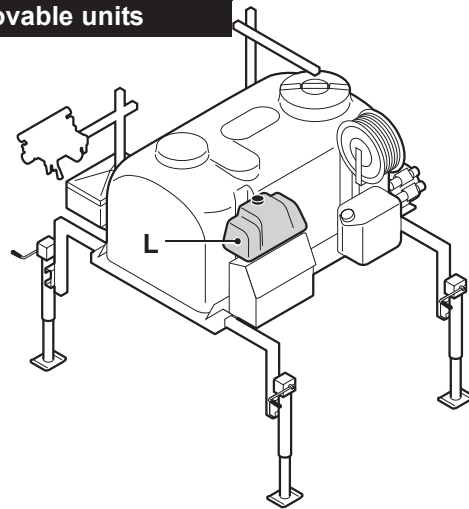

INFORMATION: In case of accidental contact of the chemical product with skin, rinse it immediately with clean water, taking it from the fresh water container (L)

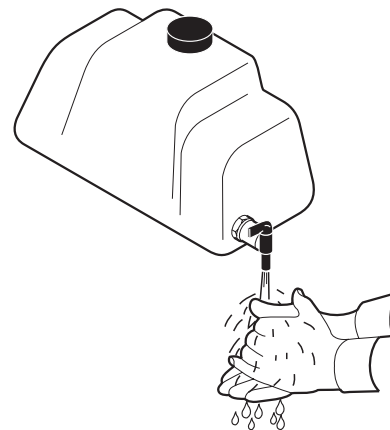

IDM-37.045Ec.0

- Close the cover and wait until the liquid level reaches half the tank.
- Open valve **E** and wait until the MIXER tank is emptied.

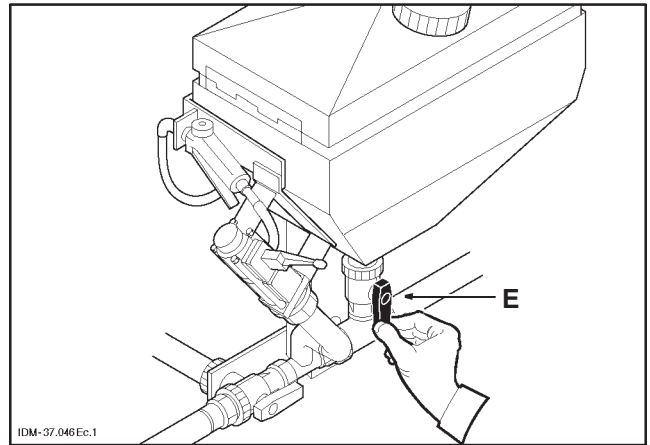

- Close valve **D**.
- Rinse the MIXER through valve **H**.

⚠ DANGER-WARNING: When performing this operation, make sure the cover is closed to prevent water jets from striking the operator.

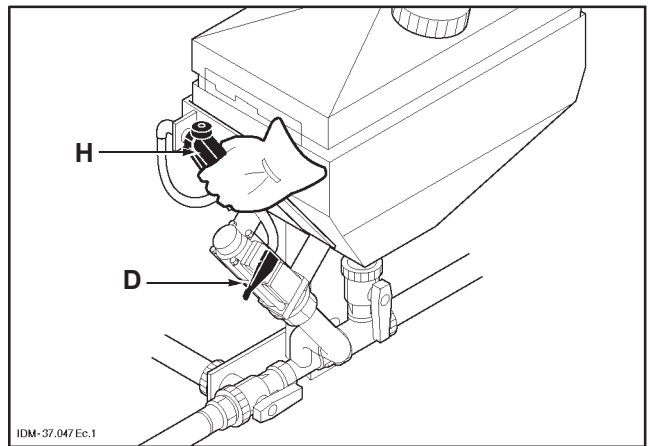

- Close valve **E** and turn lever **C** to deliver the product to the spraying boom.

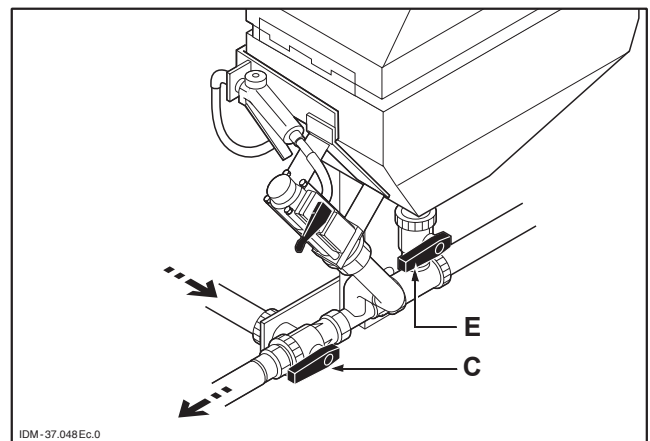

6.8. CHEMICAL PRODUCT SPRAYING

CAUTION: before using the equipment, the operator shall read and understand the manual; furthermore, he shall carry out some training manoeuvres in order to learn the position and the controls functions.

- Make sure the product quantity is sufficient to carry out the treatment.
- Get information on the weather conditions and forecast relevant to the whole treatment period.
- Rotate cocks **C**, **D**, and **E** (if fitted) as shown in the figure.
- Check all the equipment settings and adjustments, § 5.4.
- Reach the area to be treated.
- Prepare a mixture of water and chemical product inside the tank, § 6.7.

DANGER-WARNING: Make sure there are no electric lines within the range of the spraying boom during the opening and closing phases.

CAUTION: to avoid any overturning should the ground be steeply sloping, comply with the following instructions:

- unfold the boom uphill first and always fold the boom downhill first; should the first boom to operate not be in the above described position, turn the tractor;
- never work with the only boom downhill unfolded.

- Open the spraying boom (see annex F).
- Engage the PTO to activate the pump.

CAUTION: The max. PTO rotation speed must not exceed the 540 rpm.

- Feed the spraying boom with the product, placing lever **F** as shown in the figure (for both Standard 461 and IDROMINUS distributors).
- Move switch 3 upward (for ELECTRO 461 distributors).
- Select the spraying boom sections necessary to cover the area to be treated.
- Drive the tractor forward.

INFORMATION: To keep the boom oscillation at a minimum and to obtain a uniform spraying, the forward speed should not exceed 8÷10 km/h.

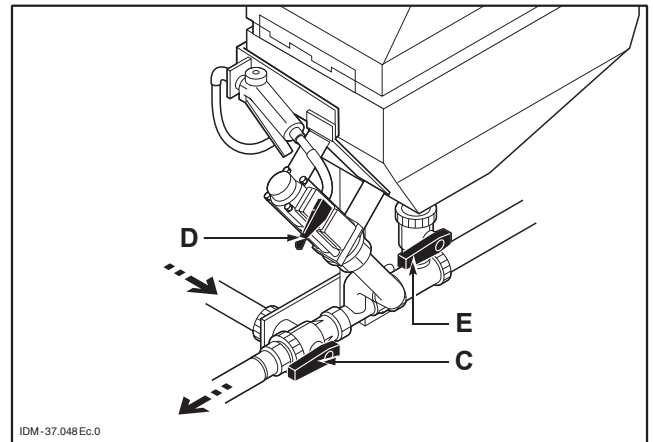

STANDARD 461

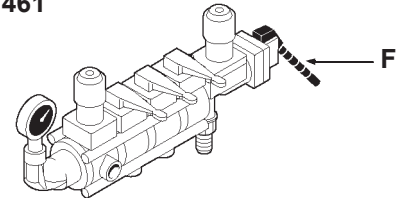

IDROMINUS

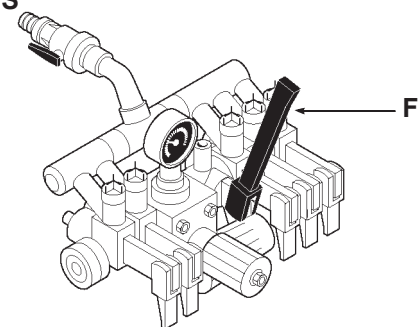

ELECTRO 461

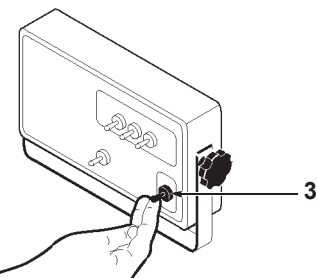

To avoid uncontrolled spraying in the environment, treatments cannot be carried out whenever the wind speed exceeds 5 m/sec. In any case, even if the wind speed falls within the limits allowed, it is of the utmost importance to take all possible precautions (reduced height of the boom, increase of the drops dimension, observance of the safety distance, etc.) to prevent the sprayed product from reaching areas different from those to be treated.

6.9. EMPTYING THE TANK FROM THE RESIDUES

⚠ DANGER-WARNING: do not dispose of the fluid in the environment, it might pollute watercourses and waterbeds. Collect the containers and dispose them of in compliance with the law in force. Keep any residues far from the reach of children.

The residual volume is the quantity of fluid remaining on the bottom of the tank at the end of the working cycle, at the first pressure drop because there is little fluid to be drained. This liquid has to be diluted with clean water in proportion of 1:10 (example: 1 litre of product / 10 litres of water) and distributed over the surface to be treated.

- Remove plug **E** and open discharge valve **D**.
- Once the emptying has been carried out, tighten lever **D** and fit plug **E**.

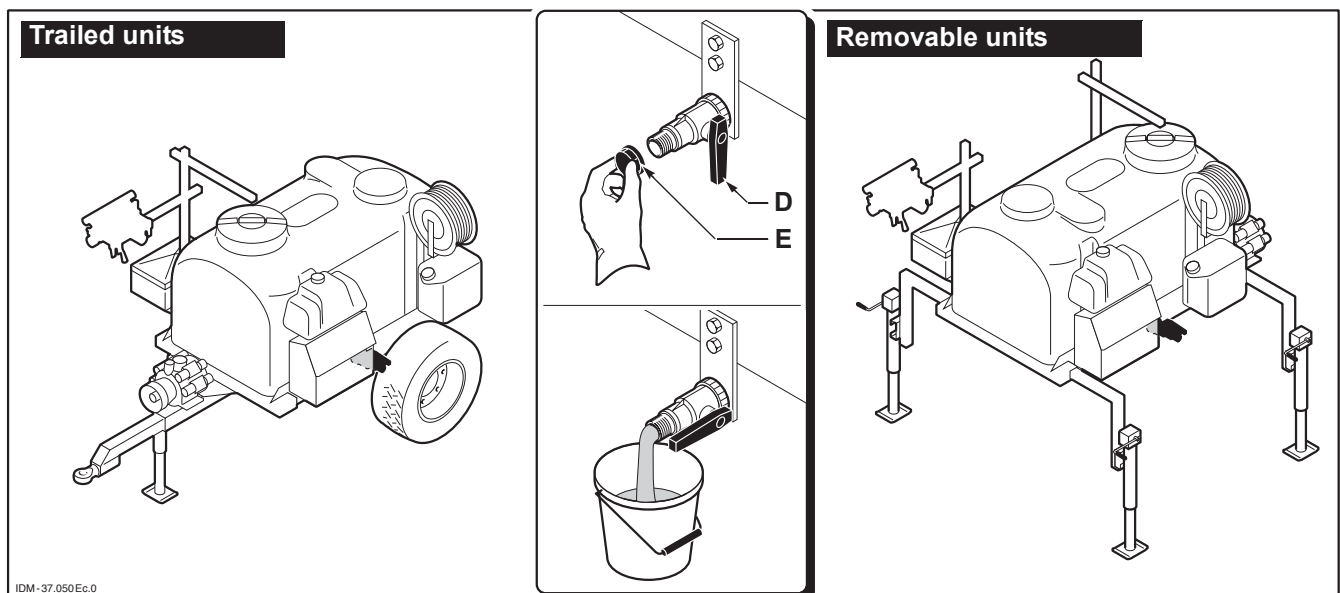
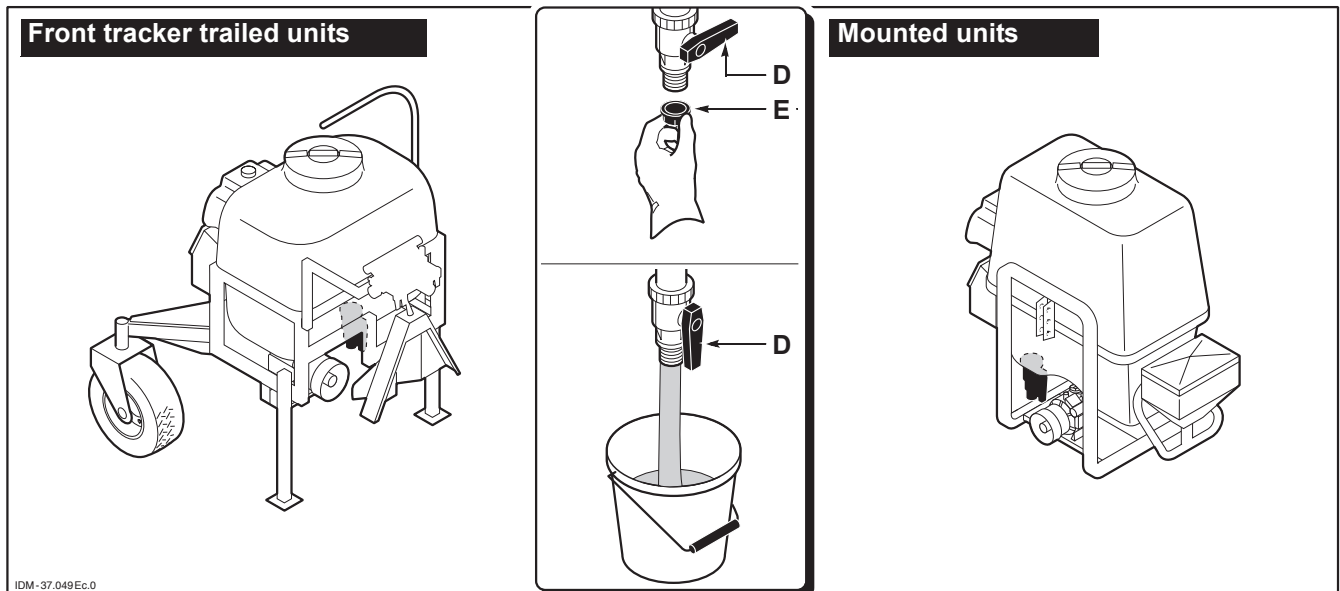

EQUIPMENT MAINTENANCE **7**

388.037

A careful and constant maintenance ensures a good working and a long life of the equipment.

 **DANGER-WARNING: both routine and un-scheduled maintenance operations must be carried out with the tractor turned off, previously disengaging the PTO.**

7.1. DAILY MAINTENANCE

□ **Cleaning the equipment:**

at the end of each working day, clean the equipment as described, making sure to wear rubber gloves, boots, goggles and suitable clothes.

 **DANGER-WARNING: never leave chemical residues in the equipment. Do not dispose of the fluid in the environment, it might pollute watercourses and waterbeds. Collect the containers and dispose them of in compliance with the law in force. Keep any residues far from the reach of children.**

- *Empty the tank (see § 6.9).*
- *Clean tank interior walls by injecting water from the main cover.*
- *Activate the pump and let it idle for a few minutes.*
- *Rinse the mixer and the by-pass piping (if fitted).*
- *Empty the tank completely (through the nozzles).*

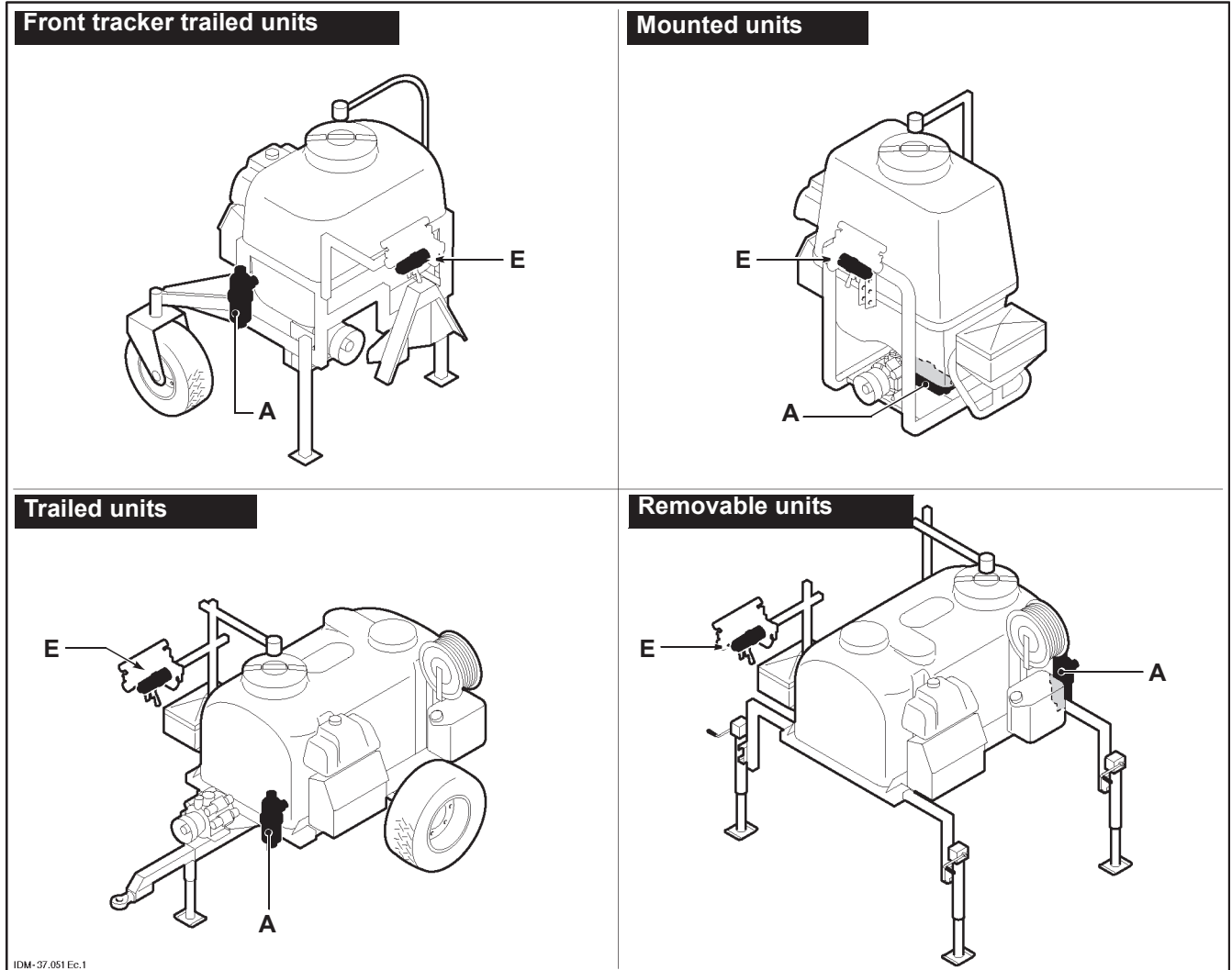

- Clean suction filter **A** (50 mesh/0.36 mm) (see section 7.2.).
- Clean delivery filter **E** in the water distributor (if fitted) (from 50 mesh/0.36 mm to 80 mesh/0.25 mm).
- Clean the outer walls with a strong water jet and with a sponge or a high pressure washing machine whenever necessary.

 **CAUTION:** clean the equipment thoroughly whenever liquid fertilizer has been sprayed.

□ Tyre pressure control

The tyre inflation pressure value must be 3.5+4 bar; check the value through a gauge, adjusting it by means of an air compressor whenever necessary.

7.2. SUCTION FILTER CLEANING

For this operation proceed as follows.

- Place a collection tub under the filter.

 - Push upwards and turn the plug to remove it.

 - Screw out the ring nut and remove the filter cover.

 - Clean the filter cartridge.

 - Install a cartridge and screw down the ring nut.
- i** **INFORMATION:** make sure that the O-ring is correctly positioned.
-
- Press the plug in by making sure that the rod is correctly positioned in its seat; lock the plug by pressing and turning it.

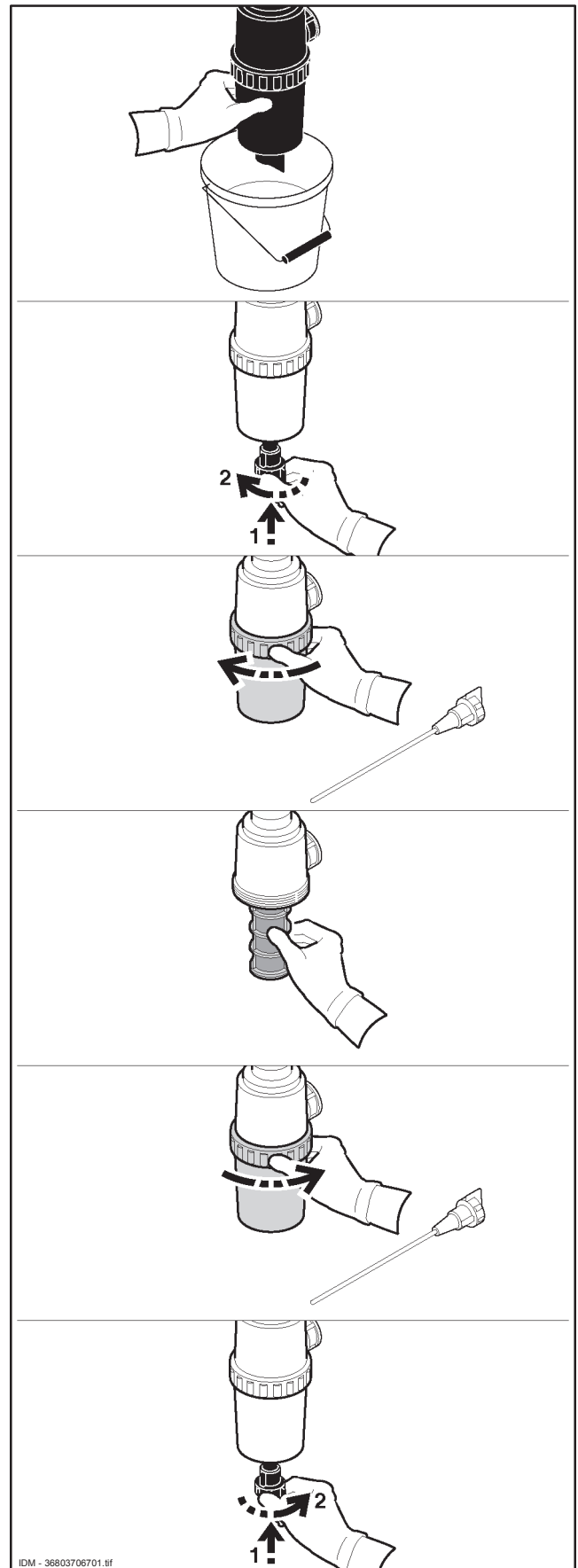

IDM - 36803706701.tif

7.3. ROUTINE MAINTENANCE - EVERY 40 HOURS

Lubricate with water-repellent grease all the sliding surfaces, particularly after a high pressure washing has been carried out.

□ Diagram of points to be greased

- Check the efficiency and tightening of the bolts, giving a particular attention to the axles and the wheels bolts.
- Retouch the damaged painted components.

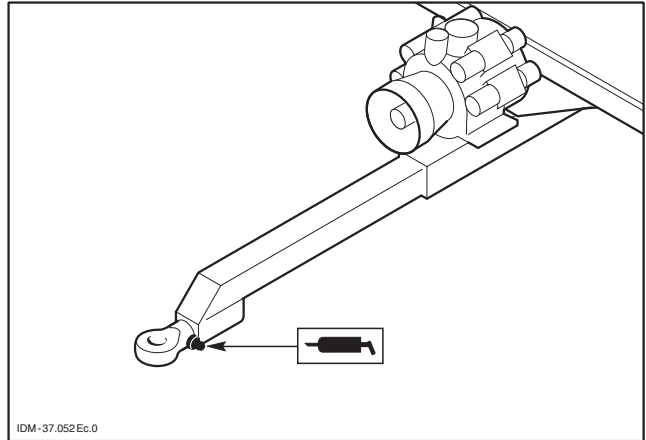

7.4. UNSCHEDULED MAINTENANCE

Unscheduled maintenance operations must be carried out in authorised workshops, duly equipped with suitable tools and performed by skilled personnel.



CAUTION: whenever welding the equipment, always empty the spraying circuit and, should the equipment be supplied with electric controls, disconnect the electric connector from the tractor.

The hydraulic system hoses are subjected to wearing, thus they must be replaced every six years from the date of the equipment manufacturing.

7.4.1 Equipment functions control devices.

The equipment may be fitted on request with the couplings and devices shown in the figure. These enable to control the main functions.

A - Coupling for pressure gauge control (1/4" Female).

B - Graduated container for nozzle flow-rate control.

C - Coupling for pump flow-rate control. (1").

This device allows to install a flow meter to control the flow rate without damaging the hoses.

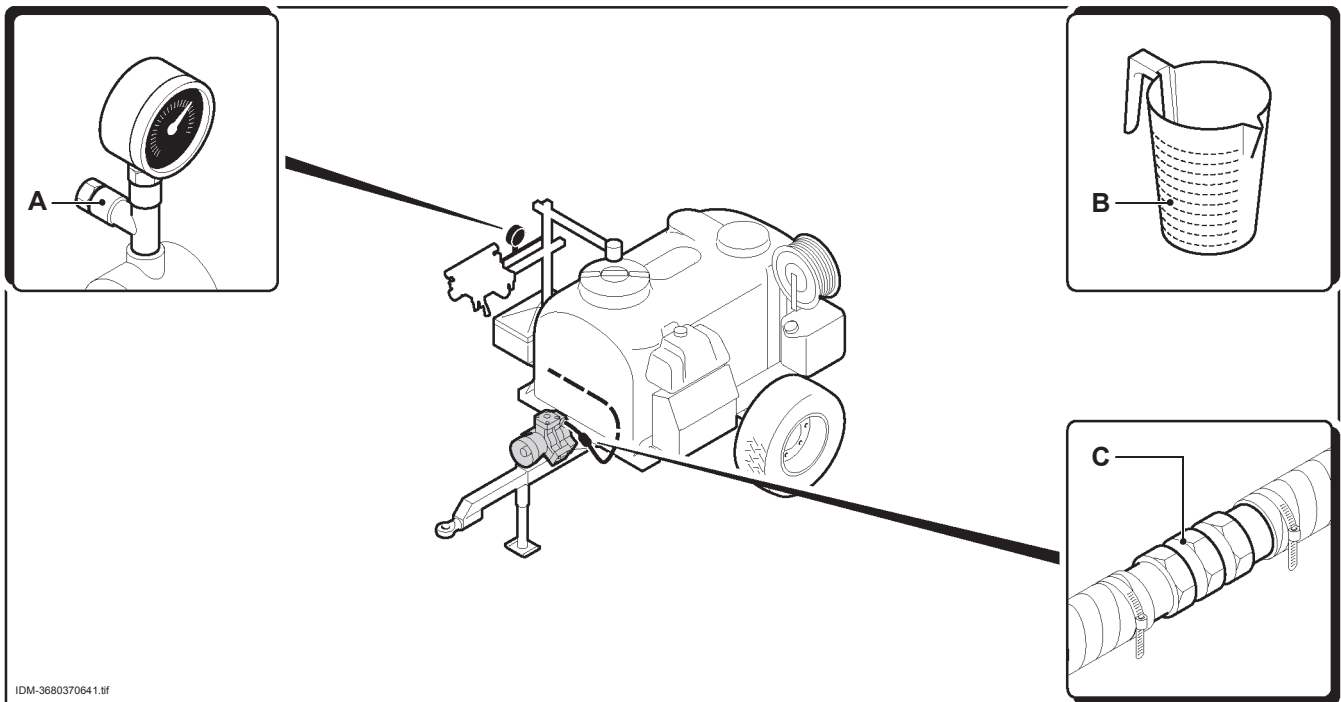

IDM-3680370641.tif

7.5. WINTER STOP



CAUTION: The equipment must be kept in a sheltered place, far from the reach of children.

Before the equipment is put away for the winter stop, carry out all the cleaning and maintenance operations, as described in § 7.1. and § 7.3.:

if the circuits have not been protected with antifreezing fluid, empty all piping to prevent the ice from damaging the circuit components (pump, distributor, filters, etc.), when severe temperature arises.

TROUBLESHOOTING 8

368.037

8.1. TROUBLES, CAUSES, CURES

<i>Trouble</i>	<i>Cause</i>	<i>Cure</i>
The pump does not deliver pressure to the distributor.	The basket strainer is clogged.	Disassemble the basket strainer and clean the cartridge.
	Pressure filter on the distributor is partially clogged.	Disassemble the filter and clean the cartridge.
	Air intake before the pump.	Check the connections sealing on the pump air intake circuit.
	Failure of one or more pump valves sealing.	Check the valves housing and clean them.
	Valves are worn-out.	Replace the valve and their housing, whenever necessary.
The pump delivers pressure to the distributor but the outlet from the nozzles is not correct.	Line filters (if supplied) are clogged.	Disassemble the filters and clean the cartridge.
	Nozzles clogged.	Disassemble nozzles and clean them.
	Foreign bodies are clogging the delivery pipe.	Disassemble the connections and make sure the seals are properly fitted. Blow air into pipes.
	Clogging of the PVC delivery pipes due to their bending.	Restore the bending radius of the pipe or replace it.
The pointer on the distributor manometer jerks.	The basket strainer is partially clogged.	Disassemble the basket strainer and clean the cartridge.
	The pump intakes air.	Check the connections seals on the air intake circuit and check the clamps tightening.
	The manometer is faulty.	Replace the manometer.
	The air chamber is deflated.	Check the chamber pressure (1/3 of the working pressure).
The pump is noisy.	It intakes air.	Check the seal of the air intake circuit.
	The oil level is too low.	Top up with SAE 20W40 oil up to fill half the tank.
The tank oil is white or oil leaks out of the tank.	One or more diaphragms are broken.	Disassemble the pump, disassemble the heads and replace the diaphragms. Top up with SAE 20W40 oil (see the pump).

