

# Installation and operating instructions

## *Level Indicator TANK-Control without immersion tube*



---

Version: V.20171210



302520-02-EN

Read and follow these operating instructions.

Keep these operating instructions in a safe place for later reference.

## Imprint

Document: Installation and operating instructions

Product: TANK-Control

Document number: 302520-02-EN

Original language: German

Müller-Elektronik GmbH

Franz-Kleine-Straße 18

33154 Salzkotten

Germany

Phone: ++49 (0) 5258 / 9834 - 0

Fax: ++49 (0) 5258 / 9834 - 90

Email: [info@mueller-elektronik.de](mailto:info@mueller-elektronik.de)

Homepage: <http://www.mueller-elektronik.de>

# Contents

<b>1</b>	<b>System description .....</b>	<b>4</b>
1.1	Fitting instructions .....	5
1.2	Display unit with sensor.....	5
1.2.1	Fitting / general indications .....	8
1.3	Automatic fill stop with Safi ball valve .....	9
1.3.1	Operating device and UNI-Control S.....	9
1.3.2	Schwitching-off with ISO-jobcomputer .....	10
<b>2</b>	<b>Operating instructions .....</b>	<b>12</b>
2.1	Calibration .....	12
2.1.1	Basic initialisation process .....	12
2.1.2	The tank table is already stored in the memory (see appendix) .....	12
2.1.3	The tank table is not yet stored in the memory .....	13
2.2	Operation .....	17
2.3	Calibration table .....	17
<b>3</b>	<b>Tips for trouble-shooting on the TANK-Control .....</b>	<b>19</b>
<b>4</b>	<b>Technical data.....</b>	<b>20</b>
<b>5</b>	<b>Appendix to the operating instructions.....</b>	<b>20</b>
5.1	List of bord computer that support TANK-Control .....	20
5.2	List of Diagrams .....	20
5.3	List of Tables.....	20
5.4	Tank type table .....	21

# Operating device

## Front panel

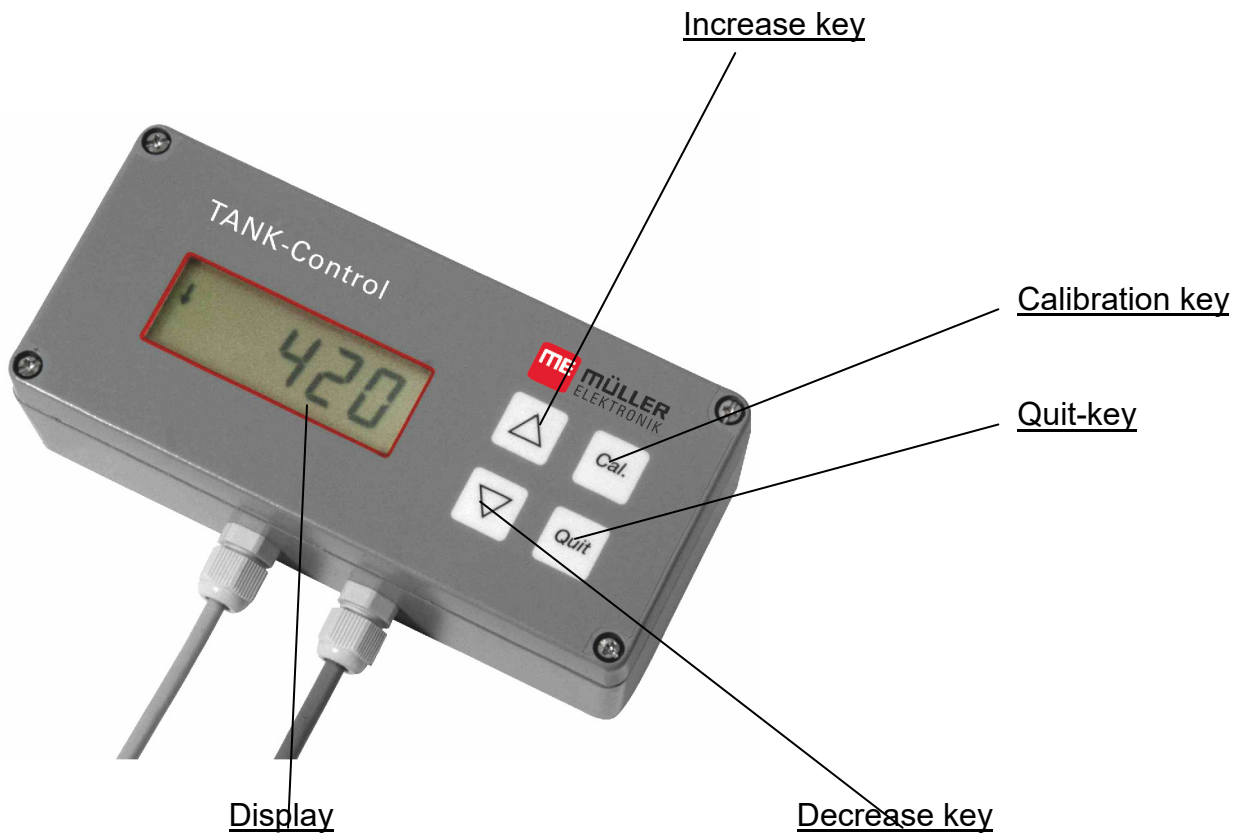

## 1 System description

The level indicator TANK-Control facilitates volume measurement with various types of tanks. It is applied mainly in agriculture for liquid fertilizer application and plant protection. The device operates with all aqueous solutions, even if their specific densities vary to that of water. By means of calibration it is possible to use different as well as irregular shaped tanks. The calibration values for the most common standard tanks are stored in the computer of the operating device. The measured values (tank content) can be retrieved from the ME bord computer<sup>1</sup> as required. When the pre-set amount is reached, the filling is switched off by the ME bord computer (provided the machine has been prepared for this purpose).

<sup>1</sup> An overview of the ME bord computers can be found in the appendix (see 5.1 page 20)

## **1.1 Fitting instructions**

## **1.2 Display unit with sensor**

The level indicator has the following parts:

- Level sensor with operating device
- 1 float
- 1 flange -140
- 1 Viton gasket -140
- 4 Viton gaskets - 25x8x3
- 4 hexagon screws - M 8x35
- 4 nuts - M8
- 4 nuts - M8 flat
- 8 spring washers - B8
- 8 washers - A8.4 (large)
- 4 washers - A8.4
- 1 tube socket
- 2 Viton gaskets - 25x6
- 1 nut - M6 (self-locking)
- 1 washer 24.2x12.2
- 1 washer A6.4
- 1 locking ring

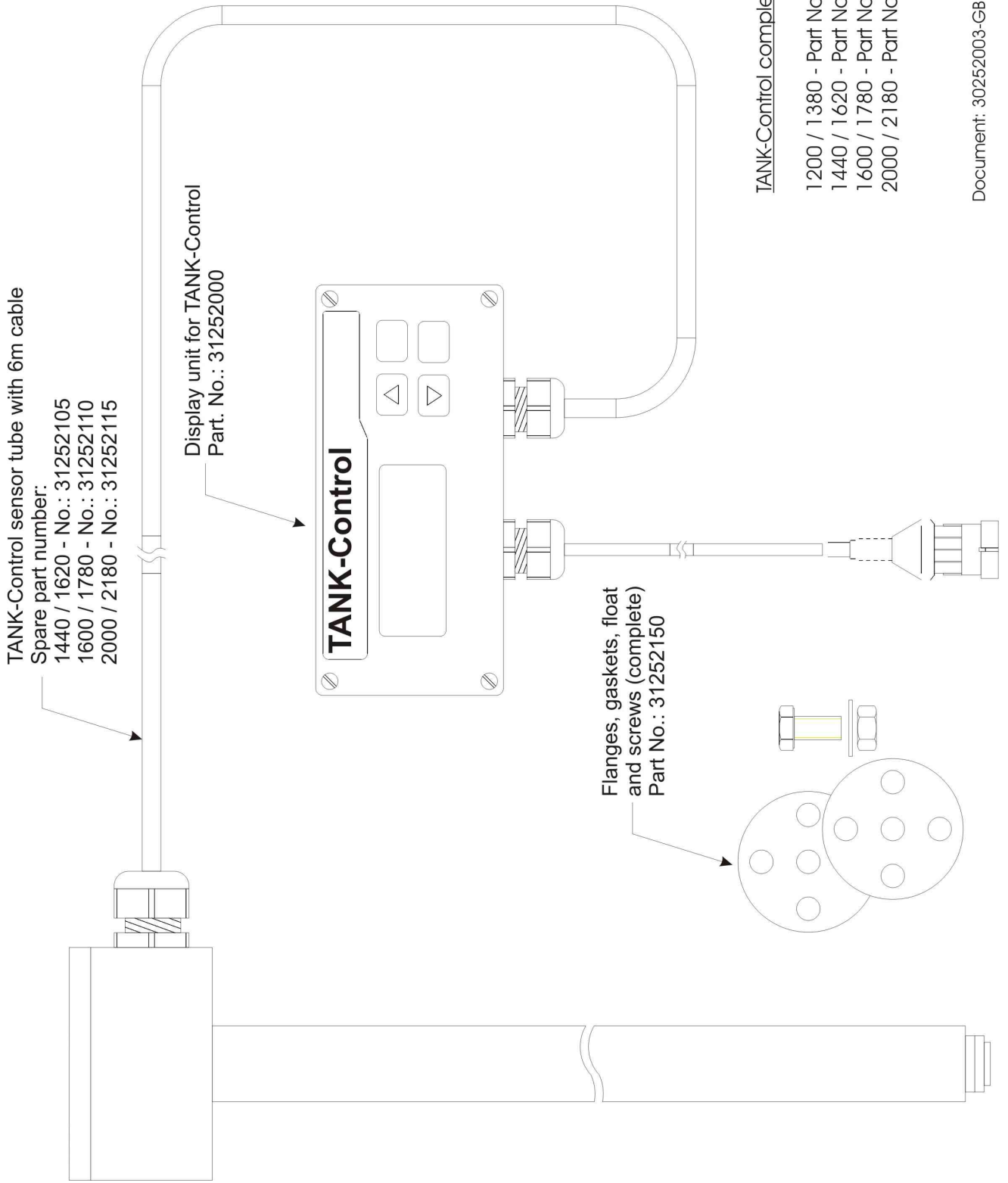

**Diagr. 1-1 Replacement parts overview**

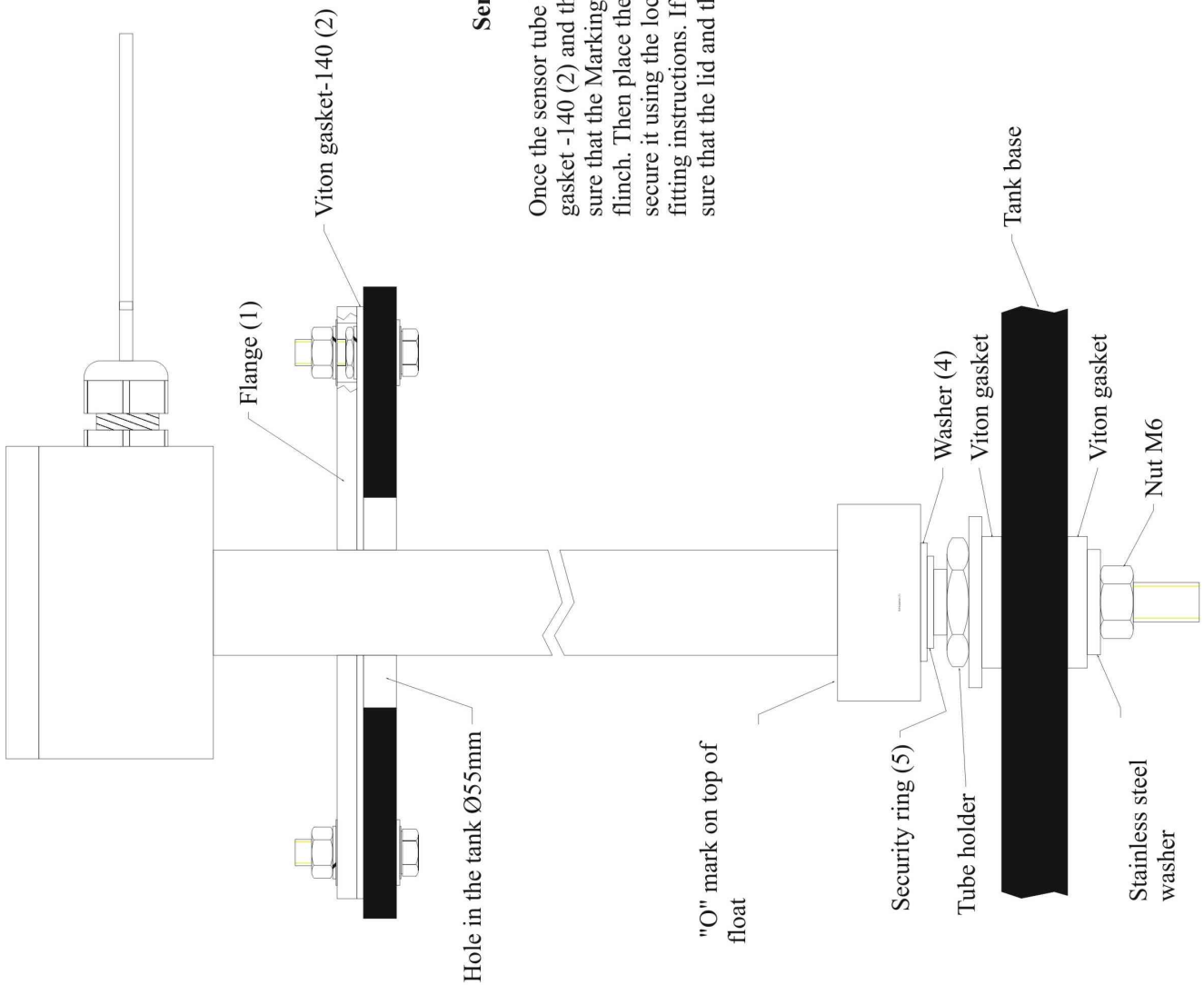

**Sensor tube - fitting instructions**

Once the sensor tube has been unpacked, slide the flinch (1), the Viton gasket -140 (2) and the float (3) from the bottom on to the tube. Make sure that the Marking "0" on the float is pointing upwards towards the flinch. Then place the washer (4) Ø 24.4 / Ø 12.2] on the tube and secure it using the locking ring (5). Refer to the diagram for further fitting instructions. If the cable is clamped in the terminal box, make sure that the lid and the cable screws are tightly screwed.

**Diagr. 1-2 TANK-Control fitting parts overview**

## 1.2.1 Fitting / general indications

Before drilling into the tank, check first that there is enough room for the immersion tube inside the tank and that there is no obstruction caused either by pipes or struts. The function of the Tank-Control level sensor can only be guaranteed when it is installed vertically. With the aid of the installation diagram, carry out the following steps:

1. First of all, using the flange bore 4 holes (8.5 mm diameter) in order to secure the flange and the 55 mm opening.
2. Bore a hole in the base of the tank (6.2 mm diameter) to take the tube holder. Determine the position for boring by means of a plumb bob, proceeding from the centre of the opening on the tank lid. In this way the vertical installation of the sensor tube is guaranteed.
3. Mount the tube socket as illustrated in the mounting diagram.
4. Mount the flange (1), Viton gasket (2), float (3) (point the float with the front surface marked with an "O" towards the cable outlet) in that order on to the sensor tube and secure with a washer (4) and a security ring (5) to avoid slipping. Carefully loosen the security ring using security ring pliers as far as required so that it can be screwed over the screw thread.
5. Once the sensor tube has been assembled as described above lead it through the opening in the tank lid and screw it into the tube socket on the base of the tank.
6. Mount the flange using M8 hexagon screws.
7. In order to simplify dismantling, should this be necessary, take the cable from the operating device and secure the surplus cable in a loop near the sensor tube with cable ties. When dismantling always disconnect the cable on the sensor tube.



### Connecting the operating device

Connect the operating device to the power supply of the tractor, so that the maximum voltage (13.8V) cannot be exceeded.

The cable has the following connections:

white	ground
brown	+ 12 V power supply
green	signal output for ME bord computer

### **Do not use a high-pressure cleaner to clean the sensor or operating device**

### **Do not open the operating device. The warranty is no longer valid once the seal is broken:**

Please observe the following points when opening devices which are no longer covered by warranty.

- Once the lid of the casing has been opened tighten the screws again carefully in order to avoid the lid becoming distorted.
- When changing cables or opening PG screw plugs use a suitable sealant (e.g. non-ascetic silicone) to seal inside the cable screw plugs. Make sure that the earth claw always fits on the cable screw plug.

## **1.3 Automatic fill stop with Safi ball valve**

In connection with the UNI-Control S, the filling operation can be switched off when the pre-set amount has been reached. The safi ball valve (1 1/4", 1 1/2" or 2") is fitted to the sprayer at a suitable point in the filling tube. The operating device is fitted near the ball valve.

### **1.3.1 Operating device and UNI-Control S**

The operating device is connected in the manifold signal distribution box.

After fitting the filling tube, the ball valve is always opened manually with the S1 switch. A switch-off delay of 10 seconds guarantees that the ball valve fully opens, as the ball valve can only be closed from a completely open position.

When the required amount has been reached, the UNI-Control S puts out a pulse via the control line d16 and the ball valve slides shut. The filling operation can also be stopped manually using the S1 switch.

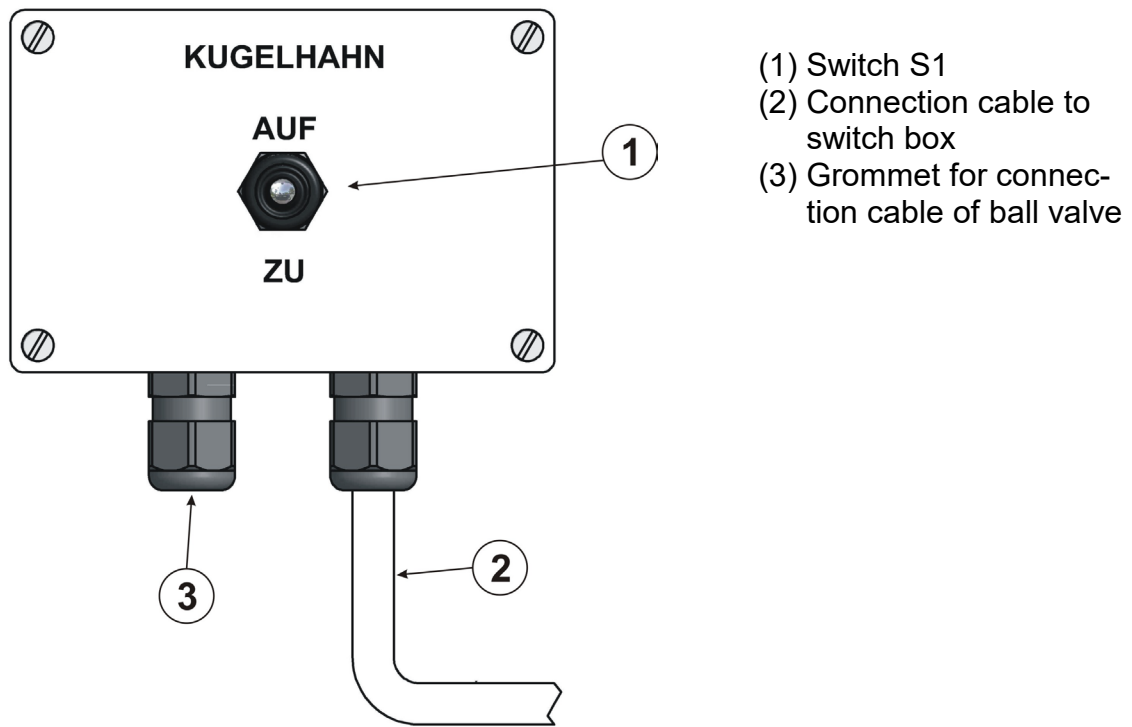

**Diagr. 1-3 Fill stop operating device for UNI-Control S**

The operating device can be ordered with the part no.: 302528.

### **1.3.2 Switching-off with ISO-jobcomputer**

The operating device for ISOBUS-ECUs can be connected to the wire harness with a 6 pin AMP connector. An extension cable is available for machines with junction box.

The ball valve is connected directly to the operating device.

The operating device can be ordered with part number: 30252820. The extension cable has part number: 30303280.

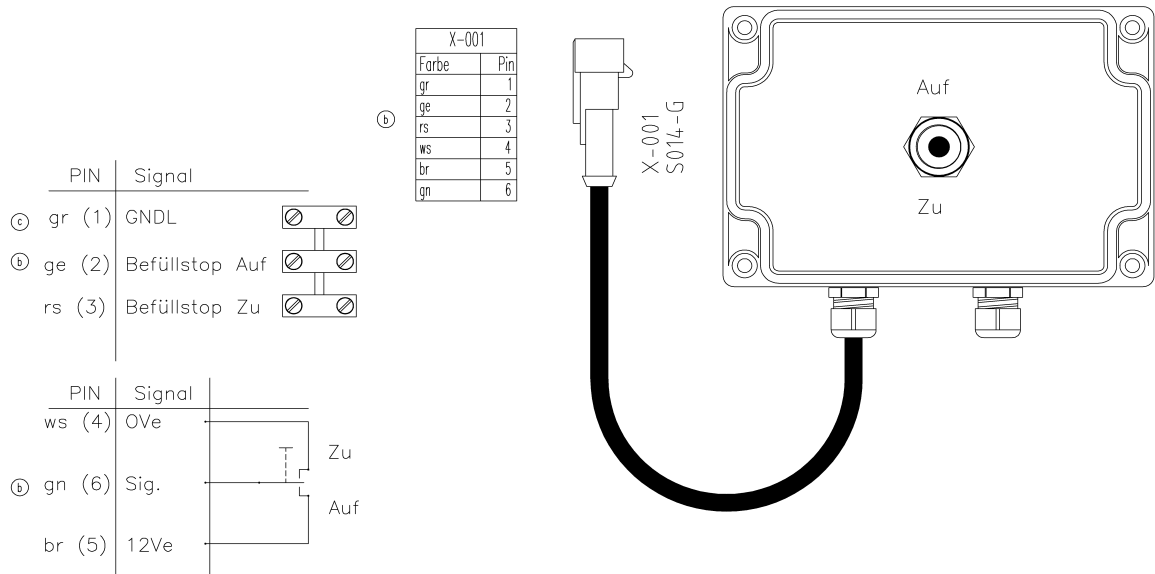

**Diagr. 1-4 Fill stop operating device for ISOBUS ECUs**

For operating instructions of the fill stop function please refer to the instruction book of the ISOBUS ECU.

## 2 Operating instructions

### 2.1 Calibration



Before initial operation, the Tank-Control requires the tank table (level of tank content). Up to 20 calibrations per tank can be carried out. This means that even the contents of irregular sized tanks can be recorded. For some tanks (see appendix) the table has already been stored in the memory. In this case calibration is not necessary. All that is required here is a 100l alignment.

#### 2.1.1 Basic initialisation process

To ensure that the level indicator functions correctly a basic initialisation is to be carried out prior to initial operation.

##### **Basic initialisation is also to be carried out**

if "0000" appears on the display when the device is switched on. Proceed as follows:

1. The float must be in the lowest end position (tank empty otherwise pull out the immersion tube).
2. Press the keys  and  simultaneously (ca. 3s) until "8888" appears on the display. Release the keys. Basic initialisation is now completed.
3. If the immersion tube was pulled out, mount it correctly once more.

Switch off the device after basic initialisation has been completed. If "0000" appears on the display when the device is switched on repeat the procedure. Beforehand check that the float really is at the bottom of the immersion tube.

If after switch-on "0000" still appears on the display, then there is a fault in the device.

#### 2.1.2 The tank table is already stored in the memory (see appendix)

After the installation has been completed, the type of tank can be entered according to the table.



##### **Preparation**

- set up the field sprayer in a horizontal position
- open the tank outlet
- fill with water until it runs out of the tank outlet
- turn off the flow of water and as soon as water is no longer running out of the tank outlet, close it.

##### **Switch on the device**



The length in cm, which the level indicator in use can measure, appears for a short time on the display.

### Select tank setting

- press and hold the key 
- press key 
- release keys

A **C**, a small circle and an arrow appear on the left-hand side of the display, on the right-hand side a number flashes; this number corresponds to the pre-set tank number. (see appendix).



### Select the type of tank

- select the number of the tank being used from the tank table (appendix)
- with the key  or  set the tank number
- press the key 

The operating mode "tank content" is activated, the characters on the left-hand side of the display (**C**, circle and arrow) disappear. The tank content is displayed (in litres).

### 100 litres calibration

The 100 litres calibration must be carried out, as small variations can occur in the height of the tanks.

- fill the tank with 100 litres of water
- press the key  and the key  simultaneously.

A corrected value followed by the 100 litre volume display is shown. The device is now calibrated to a tank content of 100 litres.

## 2.1.3 The tank table is not yet stored in the memory

During the calibration process, the measured values delivered from the level sensor are combined and stored with the current level of the tank in use, which has already been recorded in the operating device.

The calibration process is carried out in 6 stages

1. Select tank number 0
2. Select operating mode tank calibration
3. Enter "tank empty"
4. Calibration step 1

In this process the smallest tank content, which can be measured by the Tank-Control, is determined using the operating device. As soon as a measurement

can be established by the sensor, a C appears on the display. The first stage can be calibrated.

## 5. Calibration steps 2 - 19

Use an accurate flow meter or vehicle scales when filling up the tank with water gradually. An incrementation (amount filled between 2 calibration steps) of a twentieth of the total volume is recommended. To ensure an accurate display of the level the incrementation should not exceed a tenth of the total volume. However a calibration step for an accurate 100 l alignment must lie at exactly 100 l. The incrementation does not have to remain constant, i.e. following calibration steps are possible: 0 l, 50 l, 100 l, 300 l, 500 l whilst a maximum of 20 calibration steps can be stored.

Please note that the calibration of the last calibration step can only be carried out when the tank is completely full.

3 stages, which are repeated for each calibration step, are required for the calibration:

1. enter the calibration step (first column in the calibration table, see appendix)
2. enter the current filled content
3. enter the measured values displayed in the calibration table

For the checking and documentation of the calibration process, the calibration values are entered into a copy of the table provided in the appendix.



## 6. End the calibration process

### Tank calibration process



#### Preparation

- set up the field sprayer in a horizontal position
- open the tank outlet
- fill with water until it runs out of the tank outlet
- turn off the flow of water and as soon as water is no longer running out of the tank outlet close the tank outlet.

#### Select tank number 0 (self-calibrated tank)



- press and hold key 
- press key 
- release keys

A **C**, a small circle and an arrow appear on the left-hand side of the display simultaneously, on the right-hand side a number flashes; this number corresponds to the preset tank number.

- with key  set tank number 0
- press key 



The tank number 0 has been selected.

### Set operating mode tank calibration

- switch the device off and on
- press and hold 
- press key 
- release keys
- A **C** (calibration) appears on the left-hand side of the display, on the right-hand side a "0" flashes.



### Enter empty tank

Empty the tank

- press key 
  - 0 (0 litres) appears on the display.
  - press key 
  - the measured value appears on the display (enter in the table)
  - press key 
- 0 (calibration step 0) flashes on the display.



**Before entering each measured value allow any ripples in the tank to subside.**

### Calibration step 1

- calibration step 0 (flashing) shows on the display.
  - key 
  - 1 flashes on the display (calibration step 1)
  - press key 
- 0 (0 litre tank content) appears on the display

**Fill the tank slowly until the `C` appears on the left-hand side of the screen  
stop filling (as a rule, a first measurement can be recorded with the calibra-**







**tion step 0. In this case 0 litres tank content must be set for calibration step 1 as well. Go on with calibration step 2).**

- press   to set the current tank content in litres
- press key 
- the level of the filling is displayed (5 or 0 as last position) in mm (enter in to table)

press key   
1 flashes on the display (calibration step 1)

The calibration step 1 determines the smallest value which can be measured.

**- Calibration steps 2 to max. 19**



- preceding calibration steps are displayed
- with the key  set the next calibration step
- press key 
- calibration step is stored, the content (litres) of the preceding calibration step is displayed
- fill the tank with the set amount of water (next step size)
- (calibration step 2 = 100 litres !)
- with the keys   enter the new content (enter in table).
- press key 
- tank content is stored, the new tank value is displayed (enter in table).
- Press key 
- measurement is stored

The calibration can be carried out in the opposite direction in the same way, i.e. whereby a full tank is emptied. Make sure that in this case the process starts with calibration step 19 and a full tank.

**End calibration process**



The calibration process can be interrupted as well as ended after completion. After an interruption, the calibration process can be continued at the appropriate calibration step. In both cases the calibration process is ended by pressing two keys simultaneously as described below. **Please note that both keys have to be pressed at the highest calibrated step, as this value has been set as the current upper limit of the level.**

- press and hold key 
- press key 

The operating mode "tank content" is activated, the C disappears, the tank content is displayed

## 2.2 Operation

After switching on the device the current measuring capacity of the sensor in use is displayed for a short time and then the tank content appears. If the number 9999 appears on the display, this means that the maximum permissible level has been exceeded.

This function is used as a safety guard. If the ME bord computer recognises the 9999I signal, it switches off the filling process, independent of the pre-set rate. Similarly, an overflow resulting from a false entry (e.g. tank content= 3000 l - value entered = 4000 l) can be avoided.

If a UNI-Control S is used, answer the question to the "tank capacity - Imp./l" enter "1".

## 2.3 Calibration table

Tab. 2-1 Example of a calibration table

Calibration step	Filled content litres	Measured value
0	0	10
1	30	15
2	100	155
3	350	325
4	500	430
5		
6		

The figures measured during calibration can be entered in Tab. 2-2. Please enter also the tank type.

**Tab. 2-2 Calibration table for self calibrated tank**

Tank type:		
Calibration step	Standard capacity Liter	Measured value
0	0	
1		
2		
3		
4		
5		
6		
7		
8		
9		
10		
11		
12		
13		
14		
15		
16		
17		
18		
19		

### 3 Tips for trouble-shooting on the TANK-Control

Problem	Cause	Solution
The length of the sensor determined during the switch-on diagnostics differs from the actual measured length of the level sensor used. (e.g. 0 or 556)	Faulty cable connection between operating device and sensor.	Check cable connection and if necessary repair
	Sensor or operating device is defective	Replace sensor tube. If still faulty send in the complete device for repair.
9999 displayed	The float is not on the sensor or the float is installed the wrong way round	Install float Turn float
	Float magnets are demagnetised	Replace float
	max. filling limit exceeded	
	Float is outside the measuring area	
"0000" displayed at switch-on	False values in EEPROM	Carry out basic initialisation. If error remains send in the complete device for repair
During tank calibration values are determined in the calibration steps which are lower than the previous values	Movement of the float on the sensor tube due to ripples in the tank	Wait for the ripples to subside before storing values

## 4 Technical data

Tab. 4-1 Technical data

<b>Power supply:</b>	10.5 V – 16 V
<b>Temperature range:</b>	-20 °C – 50 °C
<b>Casing:</b>	Durable Aluminium
<b>Safety class:</b>	IP 65
<b>Measurements operating unit:</b>	175 mm x 110 mm x 60 mm (WxHxD)

## 5 Appendix to the operating instructions

### 5.1 List of bord computer that support TANK-Control

#### Only display of tank content

- SPRAYDOS
- LBS-Control
- ECO-Terminal with ECO field sprayer ECU

#### Display of tank content and automatic fill stop

- UNI-Control S
- BASIC-Terminal with ISOBUS field sprayer ECU
- BASIC-Terminal TOP with ISOBUS field sprayer ECU

### 5.2 List of Diagrams

Diagr. 1-1 Replacement parts overview.....	6
Diagr. 1-2 TANK-Control fitting parts overview.....	7
Diagr. 1-3 Fill stop operating device for UNI-Control S.....	10
Diagr. 1-4 Fill stop operating device for ISOBUS ECUs.....	11

### 5.3 List of Tables

Tab. 2-1 Example of a calibration table.....	17
Tab. 2-2 Calibration table for self calibrated tank.....	18
Tab. 4-1 Technical data.....	20
Tab. 5-1 Tank type table Version: 16.06.2017.....	21

## 5.4 Tank type table

Tab. 5-1 Tank type table Version: 16.06.2017

Tank number	Company / Tank name	Capacity (Liter)
0	selbstgeeichtes Faß	
1	Dammann 2800	3000
2	Holder- ASP	2700
3	Dammann 4000	4000
4	Schmotzer- ASP	2500
5	Dammann 3000	3000
6	Jacoby Eurotrain 2500	2500
7	Amazone UG 3000	3000
8	Sieger HD 5000	5000
9	Amazone UF 1200	1200
10	Dubex	3000
11	Hoegen Diekhoff	3000
12	SIEGER HD 3500	3500
13	Dammann 2000 ohne Einb.	2000
14	AGROTRONIX 475	475
15	TECNOMA 4200	4200
16	Dammann 5000	5000
17	Kundenfaß	12000
18	Sieger TSMR	3000
19	Sieger TSMR	3600
20	Sieger TSMR	4200
21	Inuma ITAS Bauf. Z ab Bj. 2002	3500
22	Inuma IAS bis Bj. 1999	4500
23	Inuma IAS bis Bj. 1999	4000
24	Inuma IUAS Bauf. C bis Bj. 1999	2000
25	Sieger HD	3500
26	Lemken Eurotrain TC 2600	2600
27	Jacoby Eurotrac 2000 I	2000
28	Bartoud 3200 I	3200
29	Agrevo	200
30	Agrevo	1000
31	Lemken Eurotrain TC 3500	3500
32	Alys (Vicon)	3500
33	HARDI TZ 3500	3500
34	Amazone UG 3000 anderer Einbau als Faß 7	3000
35	Beyne 3700	3700
36	Beyne 2700	2700
37	BBG	3300
38	Amazone UG 4500	4500
39	Inuma IUAS Bauf. I	2000
40	Inuma IUAS Bauf. I	3000
41	Inuma IUAS Bauf. I	3500
42	Inuma ITAS Bauf. R ab Bj. 2002	4000
43	Inuma ITAS Bauf. R ab Bj. 2002	5000
44	Jacoby Eurotrac	2000
45	Dammann 2900	2900

Tank number	Company / Tank name	Capacity (Liter)
46	EEFTING 5500L	5500
47	AGREVO 50L	50
48	DUBEX Junior	2400
49	DUBEX Nestor	3100
50	DUBEX Mentor	4255
51	Sieger TSMR 5000	5000
52	EEFTING	4200
53	EEFTING	3000
54	EEFTING	3800
55	DUBEX Stentor	6750
56	Dammann 5000i gerade	5000
57	Dammann 4000i gerade	4000
58	Amazone UG2200	2200
59	John Deere Typ 638	3800
60	Schmotzer ASP 3800	3800
61	Dammann 5800 gerade	5800
62	HARDI COMMANDER 4200	4200
63	HARDI COMMANDER 2800	2800
64	HARDI COMMANDER 3200	3200
65	nicht belegt	
66	DAMMANN 7000i gerade	7000
67	DUBEX Modell 8	1100
68	EEFTING	3300
69	Lemken Eurotrain TC 5000	5000
70	SCHMOTZER ASP 2700	2700
71	DUBEX Vector 3200L	3200
72	nicht belegt	
73	BBG SF430	3400
74	BBG SF430	4000
75	EEFTING 7200L	7200
76	RTS – Albatros 35	3200
77	DUBEX Modell 8	700
78	DUBEX Nestor	900
79	EEFTING 5600L	5600
80	RTS – Albatros 45	4250
81	RTS – Albatros 55	5480
82	nicht belegt	
83	EEFTING 3800L FUSEE	3800
84	RTS Albatros 65	6450
85	RTS Spritze 40	4100
86	EEFTING 2700L	2700
87	EEFTING 3300L	3300
88	DAMMANN FEA 15035	15000
89	EEFTING 4200L	4200
90	RTS Albatros 25	2400
91	Dubex Aufbau	3000
92	Inuma IAS Evo	3500
93	Inuma IAS Evo	4000
94	Inuma IAS Evo	4500
95	Inuma IAS Evo	5000

<b>Tank number</b>	<b>Company / Tank name</b>	<b>Capacity (Liter)</b>
96	Inuma IAS K	2000
97	Inuma IAS K	2500
98	Inuma IAS K	3000
99	Inuma IUAS BauF.C ab Bj. 2000	2000
100	Lemken Albatros 30	3000
101	Lemken Albatros 40	4000
102	DAMMANN 4000i mME	4000
103	Inuma IAS Evo	6000
104	BBG S340	4000
105	DAMMANN 4500li	4500
106	Lemken Albatros 50	5000
107	Inuma 3000I Fa.Reich	3000
108	DUBEX 12500	12500
109	DUBEX Modell 8	900
110	DUBEX Junior 1900I	1900
111	Lemken Albatros 60	6000
112	EEFTING Deichsel 2700I / 2004	2700
113	DAMMANN 4000i schräg	4650
114	DAMMANN 4500i schräg	4650
115	DAMMANN 4000i mME schräg	4580
116	EEFTING Deichsel 4200I / 2004	4200
117	Lemken Eurotrain TC 6000	6400
118	EEFTING Deichsel 5600I / 2004	5600
119	DAMMANN 5000i schräg	5000
120	Lemken Primus 35	3500
121	Lemken Primus 45	4500
122	Inuma IAS Creation 3500	3500
123	DAMMANN 8000i schräg	8000
124	EEFTING Deichsel 3000/2005	3000
125	EEFTING Deichsel 3800/2004	3800
126	EEFTING Radlenkung 5500/2005	5500
127	EEFTING Radlenkung 4300/2005	4300
128	Inuma IAS 4000 Fa. Hollweck (U 400)	4000
129	EEFTING 3300I Fusee model(2005)	3300
130	Dammann 4000SK gerade	4000
131	Inuma 3000I Fa.Zunhammer	3000
132	Inuma 3000I Fa.Lätzsch	3000
133	Inuma ITAS 4500I Fa.Zunhammer	4500
134	Agrifac GNS 4200	4200
135	Agrifac ZA 2700	2700
136	EEFTING 4200 Deichsel Model 2006	4200
137	EEFTING 2700 Deichsel Model 2006	2700
138	EEFTING 3800/3900 Knik Model 2006	3800/3900
139	COSMO 4000	3850
140	MAP II HIDRO 3500 H	3500
141	MAP II 3000 F	3000
142	AGRIO M3000	3400
143	AGRIO M3500	3970
144	AGRIO M4000	4700
145	AGRIO M6000	6745

<b>Tank number</b>	<b>Company / Tank name</b>	<b>Capacity (Liter)</b>
146	ABEMEC 3100	3100
147	DUBEX 12500 (Anzeigewert*10)	12500
148	AGRIO 5000	5250
149	Schmotzer 2000 Aufbau	2050
150	Agrio 3800	4000
151	Ag Chem RG 618-A / 5000	5500
152	EEFTING Deichsel 6000	6150
153	Agrifac GNS 5800	5900
154	Inuma 3000l CHEMO Farm-Star	3000
155	Inuma 4000l CHEMO Farm-Star	4000
156	Inuma 3500l Lätzsch IUAS	3500
157	Lemken Primus 25	2510
158	Dubex Actor 5000	5650
159	Lemken Albatros 20	2050
160	DAMMANN 3000i	3450
161	DAMMANN 5000i S	5300
162	DAMMANN 5000 i m ME	5550
163	DAMMANN 6000i S	6565
164	DAMMANN 10000 i m ME	11200
165	DAMMANN 10000i	11000
166	DUBEX Junior 2400/2008	2400
167	Knight Muller Tank 3500l SP GRP	3500
168	Knight 3800l	3955
169	Agrifac GNS 7200	7160
170	AGRIO 3500 CZ	3600
171	AGRIO 4000 CZ	4200
172	Lemken Sirius 900	970
173	Lemken Sirius 1300	1400
174	Lemken Sirius 1600	1700
175	Lemken Sirius 1900	2000
176	Agrio 2500	2625
177	Agrio 8000	8250
178	Inuma Marathon 10000	11200
179	Inuma Marathon 13000	14400
180	CAFFINI Prestige 5500	5500
181	DAMMANN 7000i S	7650
182	EEFTING Knik D3600	3800
183	EEFTING Knik D3000	3400
184	Bräutigam HAS45	4500
185	DAMMANN 8000i schräg 2009	8760
186	Knight Self Propelled 3500l GRP	3550
187	Knight EUA 3000l GRP	3100
188	Knight EUA 4000L GRP	4100
189	GABO 3000l	3050
190	DAMMANN 12000i	13350
191	DAMMANN FEA8000	8800
192	Inuma Professional Chemo 6000 - 09	6400
193	Inuma Professional Chemo 7000	7600
194	Inuma Professional Chemo 8000	8500
195	Inuma Marathon 10000 Zun.	10600



<b>Tank number</b>	<b>Company / Tank name</b>	<b>Capacity (Liter)</b>
196	DAMMANN 2000 MBP	2200
197	DAMMANN 5800 RRW	6250
198	DAMMANN 6000i meRRW	6700
199	DAMMANN 6000i S2010	6700
200	DAMMANN 12000i RRW	13350
201	Agrio 3000 Tiger	3150
202	Agrio TC 7000	7300
203	Agrio 2000 Tiger	2100
204	DAMMANN 5000 is RRW	5600
205	DAMMANN 6000 is RRW	6800
206	DAMMANN 8000 i RRW	8900
207	DAMMANN 4000 i GN	4500
208	DAMMANN 4000 ime GN	4500
209	DAMMANN 4000 ime RRW GN	4700
210	DAMMANN 5000 i S2010	5650
211	DAMMANN 5000i schräg RRW	5700
212	DAMMANN 7000 is RRW	7800
213	DAMMANN 8000 i GN	8850
214	DAMMANN 8000i me RRW	8700
215	DAMMANN 8000i schräg RRW	8700
216	DAMMANN 10000 ime RRW	11700
217	CAFFINI Prestige 3300	3300
218	CAFFINI Prestige 5500	5500
219	BOTALON TRASERO MAP II 2850 2010	2920
220	BOTALON TRASERO MAP II 3250 2010	3310
221	BOTALON DELANTERO MAP II 3250 2010	3270
222	BOTALON TRASERO MAP II 3500 2010	3600
223	BOTALON DELANTERO MAP II 3500 2010	3550
224	BOTALON TRASERO MAP II HIDRO 4000 2010	4030
225	AGRIO Dino 8000	8500
226	TECNOMA TECNIS 3500	4060
227	TECNOMA TECNIS 4500	4820
228	TECNOMA TECNIS 6000	6520
229	TECNOMA FORTIS 3300	3535
230	TECNOMA FORTIS 4300	4750
231	TECNOMA LASER PR2540	2760
232	TECNOMA LASER PR3240	3500
233	TECNOMA LASER PR4240	4660
234	TECNOMA LASER PR5240	5610
235	AGRIO M6500	6850
236	DAMMANN 5000 ime RRW	5800
237	DAMMANN 6000 ime	6700
238	DAMMANN 10000 i RRW	11700
239	Schmotzer ASP 5000	5400

<b>Tank number</b>	<b>Company / Tank name</b>	<b>Capacity (Liter)</b>
240	Horsch Leeb PT270 bis Fahrgestellnummer 25000109	8090
241	Horsch Leeb GS6000	6630
242	Horsch Leeb GS8000 bis Fahrgestellnummer 36000024	8185
243	Horsch Leeb GS8000 ab Fahrgestellnummer 36000025 und Horsch Leeb 8GS	8115
244	Leeb 7 GS	7280
245	AGRIO SAMEC 2500L	2580
246	AGRIO SAMEC 3000L	3150
247	AGRIO SAMEC 3500L	3500
248	AGRIO DINO 6000 L	6500
249	AGRIO DINO 7000 L	7350
250	VOGEL & NOOT IS PRO 1480	1500
251	VOGEL & NOOT IS PRO 2000	2000
252	VOGEL & NOOT IN 280	2700
253	VOGEL & NOOT IN 360	3600
254	INUMA IAS 14000 Liter Fa. Zunhammer	14100
255	Horsch Leeb PT270/280 Fahrgestellnummer 25000110 bis 25000259 (ohne 25000254)	8000
256	entfällt (siehe 243)	8380
257	Leeb 6 GS	6510
258	DAMMANN FEA 8000 GN	8280
259	DAMMANN 5000 ime GN	5650
260	IN460	4500
261	Schmotzer ASP4000	4400
262	TECNOMA Tecnis 3100	3260
263	AGRIO SAMEC 3500 ab 6-2014	3650
264	AGRIO 3500 - 6-2014	3625
265	AGRIO TIGER 3500	3650
266	Knight EUD 3600	3700
267	Knight EUD 4200	4250
268	Knight KFM 1835 SP	3550
269	Knight KFM 1840 SP	4100
270	Knight KFM 2050 SP	5100
271	AGRIO.NAPA.3500.ALT.4.15	3630
272	AGRIO 3800.PE.4.15.	4050
273	AGRIO TIGER 4000.LAM.4.15	4200
274	AGRIO.6000.NEU.LAM.5.15.	6150
275	AGRIO 3200 PE ab 5.15	3400
276	AGRIO NAPA 3800 LAM ab 8.15	4000
277	CAFFINI Striker 4000	4100
278	AGRIO 5000 MAMUT.N.10.15	5250
279	DAMMANN KS5000-RCS250	5100
280	DAMMANN KS7000	7200
281	Schmotzer SUPERMAT 1600	1800
282	Schmotzer SUPERMAT 2000	2100
283	AGRIO 6500 mit Streben 2016	6800

<b>Tank number</b>	<b>Company / Tank name</b>	<b>Capacity (Liter)</b>
284	AGRIO LAM 6000-2-16	6300
285	AGRIO LAM 3000-3-16	3150
286	DAMMANN KS4500	4700
287	DAMMANN FEAT 10000	11200
288	DAMMANN 12000 imeRRW	13200
289	MGM 3000	3000
290	MGM Magnum 6200	6200
291	MASCHIO Campo 32	3215
292	MASCHIO Campo 44	4400
293	DAMMANN FEA 10000 Festaufbau	11200
294	AGRIO 3300 PE-2017	3450
295	AGRIO 3300 LAM 2017	3450
296	Horsch Leeb PT280 Fahrgestellnummer 25000254 und ab Fahrgestellnummer 25000260	8290
297	DUPORT PTW8500	8975
298	Dammann 7000imeRRW	7700
299	Dammann 12000iRRW 2018	12800
300	Dammann AMS 12000iRRW	12800
301	Dammann FEA 12000	12400
302	Dammann FEA 15000	15490
303	Dammann KS 14000	14500



